

HISTORIC RESOURCES INVENTORY

(State use only)

Ser \_\_\_\_\_ Site \_\_\_\_\_ No. \_\_\_\_\_

UTM \_\_\_\_\_ Q \_\_\_\_\_ NR \_\_\_\_\_ SHL \_\_\_\_\_

Lat \_\_\_\_\_ Lon \_\_\_\_\_ Era \_\_\_\_\_ Sig \_\_\_\_\_

Adm \_\_\_\_\_ T2 \_\_\_\_\_ T3 \_\_\_\_\_ Cat \_\_\_\_\_ HABS \_\_\_\_\_ HAER \_\_\_\_\_ Fed \_\_\_\_\_

IDENTIFICATION Cat. III

1. Common name: \_\_\_\_\_
2. Historic name, if known: \_\_\_\_\_
3. Street or rural address 218, 224, 226, 230 N. California Avenue  
City: Palo Alto ZIP: 94301 County: Santa Clara
4. Present owner, if known: See Back Address: \_\_\_\_\_  
City: \_\_\_\_\_ ZIP: \_\_\_\_\_ Ownership is: Public  Private
5. Present Use: Rental units Original Use: Rental units  
Other past uses: \_\_\_\_\_

DESCRIPTION

6. Briefly describe the present physical appearance of the site or structure and describe any major alterations from its original condition:

This cluster of four steep-roofed Colonial Revival cottages have arched windows and decorative shutters. The almost doll-house-like scale gives the entire ensemble something of the quality of a story-book illustration.

7. Locational sketch map (draw and label site and surrounding streets, roads, and prominent landmarks):

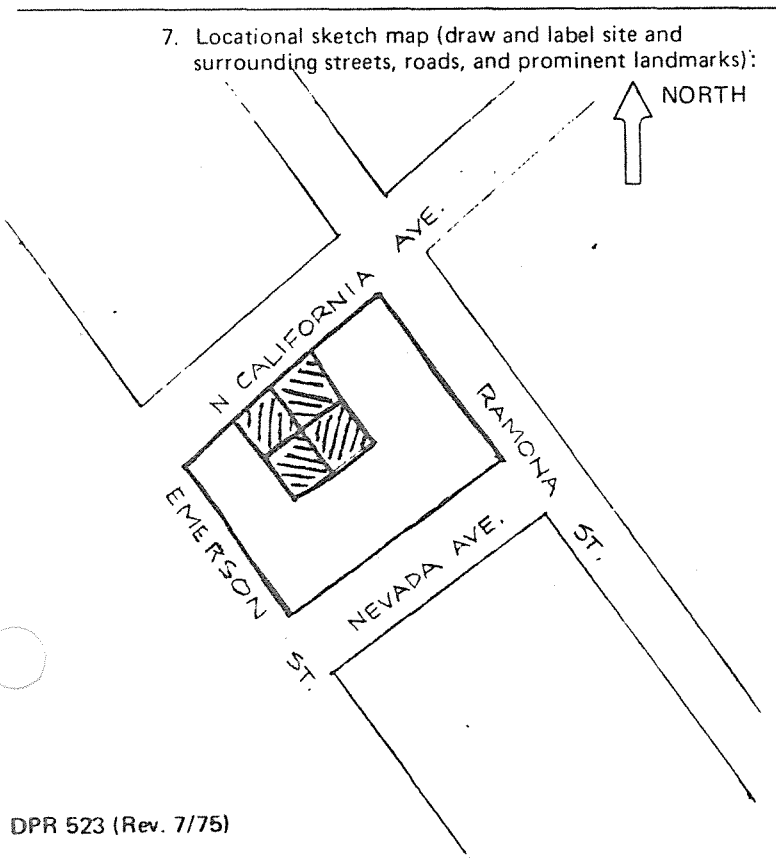

8. Approximate property size: Each approximately  
Lot size (in feet) Frontage 45.  
Depth 43.  
or approx. acreage \_\_\_\_\_.
9. Condition: (check one)  
a. Excellent  b. Good  c. Fair   
d. Deteriorated  e. No longer in existence
10. Is the feature a. Altered?  b. Unaltered?
11. Surroundings: (Check more than one if necessary)  
a. Open land  b. Scattered buildings   
c. Densely built-up  d. Residential   
e. Commercial  f. Industrial   
g. Other
12. Threats to site:  
a. None known  b. Private development   
c. Zoning  d. Public Works project   
e. Vandalism  f. Other
13. Date(s) of enclosed photograph(s): June 12, 1978

NOTE: The following (Items 14-19) are for structures only.

14. Primary exterior building material: a. Stone  b. Brick  c. Stucco  d. Adobe  e. Wood   
 f. Other  \_\_\_\_\_
15. Is the structure: a. On its original site?  b. Moved?  c. Unknown?
16. Year of initial construction 1929 This date is: a. Factual  b. Estimated
17. Architect (if known): Paul Rowan Smith?
18. Builder (if known): Paul Rowan Smith (builder and owner)
19. Related features: a. Barn  b. Carriage house  c. Outhouse  d. Shed(s)  e. Formal garden(s)   
 f. Windmill  g. Watertower/tankhouse  h. Other  \_\_\_\_\_ i. None

SIGNIFICANCE

20. Briefly state historical and/or architectural importance (include dates, events, and persons associated with the site when known):

Owners

- 218 Gladys Siemans, 429 Los Palmas Dr., SF 94127  
 224 Elizabeth R. Curren, 3470 Eden Dr., SC 95051  
 226 Elvin and Dorothy Daigle, 2120 Hanover St., PA  
 230

This is a superb example of careful planning and design for multiple unit housing. Except for Mrs. Irene M. Neely, at 218 N. California from 1953 to 1970, occupants came and went at intervals of one to three years.

21. Main theme of the historic resource: (Check only one): a. Architecture  b. Arts & Leisure   
 c. Economic/Industrial  d. Exploration/Settlement  e. Government  f. Military   
 g. Religion  h. Social/Education

22. Sources: List books, documents, surveys, personal interviews, and their dates: P.A. City Directories  
 Assessor's Books P.A. Times 11/28/28, 11/20/70

Information on the builder, P.A. Times 6/15/55

23. Date form prepared: 1978, 1985 By (name): Anne Nelson Huber; Historic Resources Board; P.A. Hist.  
 Address: 250 Hamilton Ave City Palo Alto, Ca 94301 ZIP: \_\_\_\_\_ Assn. \_\_\_\_\_  
 Phone: \_\_\_\_\_ Organization: \_\_\_\_\_

(State Use Only)

HISTORIC RESOURCES INVENTORY

(State use only)  
 Ser \_\_\_\_\_ Site \_\_\_\_\_ Mo. \_\_\_\_\_ Yr. \_\_\_\_\_  
 UTM \_\_\_\_\_ Q \_\_\_\_\_ NR \_\_\_\_\_ SHL \_\_\_\_\_  
 Lat \_\_\_\_\_ Lon \_\_\_\_\_ Era \_\_\_\_\_ Sig \_\_\_\_\_  
 Adm \_\_\_\_\_ T2 \_\_\_\_\_ T3 \_\_\_\_\_ Cat \_\_\_\_\_ HABS \_\_\_\_\_ HAER \_\_\_\_\_ Fed \_\_\_\_\_

IDENTIFICATION Cat. III

1. Common name: \_\_\_\_\_
2. Historic name, if known: \_\_\_\_\_
3. Street or rural address 355 North California Avenue  
 City: Palo Alto ZIP: \_\_\_\_\_ County: Santa Clara
4. Present owner, if known: Mary F. Rimerman Address: same  
 City: \_\_\_\_\_ ZIP: \_\_\_\_\_ Ownership is: Public  Private
5. Present Use: Residential Original Use: Residential  
 Other past uses: \_\_\_\_\_

DESCRIPTION

6. Briefly describe the present physical appearance of the site or structure and describe any major alterations from its original condition:

The two-story Craftsman structure exhibits a steeply-gabled roof with Craftsman profile eave ends. It is sheathed in shingles, and three dormer windows, extending from the roof gable, face the street. It has been enlarged at the rear.

7. Locational sketch map (draw and label site and surrounding streets, roads, and prominent landmarks):

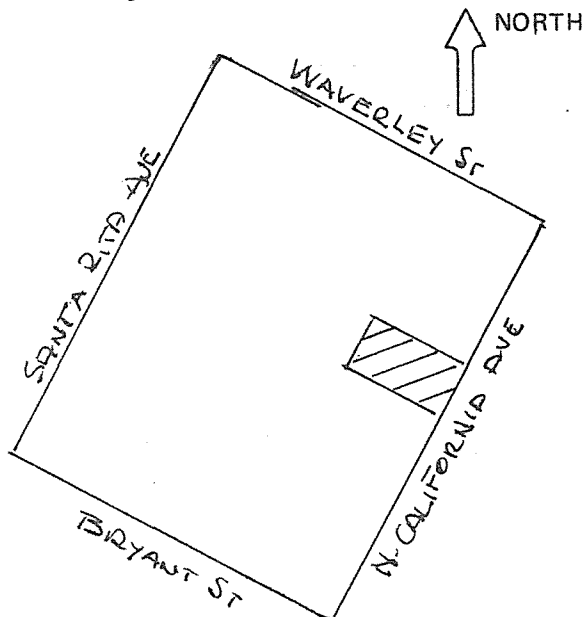

8. Approximate property size:  
 Lot size (in feet) Frontage 50.15  
 Depth 132.1 ;  
 or approx. acreage \_\_\_\_\_
9. Condition: (check one)  
 a. Excellent  b. Good  c. Fair   
 d. Deteriorated  e. No longer in existence
10. Is the feature a. Altered?  b. Unaltered?
11. Surroundings: (Check more than one if necessary)  
 a. Open land  b. Scattered buildings   
 c. Densely built-up  d. Residential   
 e. Commercial  f. Industrial   
 g. Other
12. Threats to site:  
 a. None known  b. Private development   
 c. Zoning  d. Public Works project   
 e. Vandalism  f. Other

13. Date(s) of enclosed photograph(s): 1978

355 N. California

NOTE: The following (Items 14-19) are for structures only.

14. Primary exterior building material: a. Stone  b. Brick  c. Stucco  d. Adobe  e. Wood   
 f. Other  \_\_\_\_\_
15. Is the structure: a. On its original site?  b. Moved?  c. Unknown?
16. Year of initial construction 1925 This date is: a. Factual  b. Estimated
17. Architect (if known): \_\_\_\_\_
18. Builder (if known): L.E. Kingham
19. Related features: a. Barn  b. Carriage house  c. Outhouse  d. Shed(s)  e. Formal garden(s)   
 f. Windmill  g. Watertower/tankhouse  h. Other  \_\_\_\_\_ i. None

SIGNIFICANCE

20. Briefly state historical and/or architectural importance (include dates, events, and persons associated with the site when known):

This is a particularly well-executed representation of the Craftsman-shingle style. The dormers extending from the steeply-pitched roof, and small-paned windows add interest to the design. The house was built for Rev. David Evans and his wife Susan.

Evans came from Wales, took his degree from Oxford in 1881, and was ordained in 1890. After coming to the United States, he served briefly as rector of Grace Cathedral in San Francisco, and then became the pastor in Palo Alto, 1910-1926, of All Saints Episcopal Church. The Evans family kept the house until about 1943. For the next 30-plus years, it was the home of the Charles M. Cross family. Cross was a geologist whose father was a professor of mechanical engineering at Stanford, 1906-32.

21. Main theme of the historic resource: (Check only one): a. Architecture  b. Arts & Leisure   
 c. Economic/Industrial  d. Exploration/Settlement  e. Government  f. Military   
 g. Religion  h. Social/Education

22. Sources: List books, documents, surveys, personal interviews, and their dates: P.A. City Directories; P.A. Times 3/24, 6/5/25; 7/12/27, 1/11/32, 9/12/32, 4/17/52  
Interview 1985, Mary Rimerman

23. Date form prepared: 1978, 1985 By (name): Anne Nelson Huber; Historic Resources Board; P.A. Hist.  
 Address: 250 Hamilton Ave City Palo Alto, Ca ZIP: 94301 Assn.  
 Phone: \_\_\_\_\_ Organization: \_\_\_\_\_

(State Use Only)



D

HISTORIC RESOURCES INVENTORY

(State use only)  
 Ser \_\_\_\_\_ Site \_\_\_\_\_ Mo. \_\_\_\_\_ Yr. \_\_\_\_\_  
 UTM \_\_\_\_\_ Q \_\_\_\_\_ NR \_\_\_\_\_ SHL \_\_\_\_\_  
 Lat \_\_\_\_\_ Lon \_\_\_\_\_ Era \_\_\_\_\_ Sig \_\_\_\_\_  
 Adm \_\_\_\_\_ T2 \_\_\_\_\_ T3 \_\_\_\_\_ Cat \_\_\_\_\_ HABS \_\_\_\_\_ HAER \_\_\_\_\_ Fed \_\_\_\_\_

IDENTIFICATION Cat. II

1. Common name: \_\_\_\_\_
2. Historic name, if known: \_\_\_\_\_
3. Street or rural address 450 N. California Avenue  
 City: Palo Alto ZIP: 94301 County: Santa Clara
4. Present owner, if known: Maxwell and Floy Bloomfield Address: Same  
 City: \_\_\_\_\_ ZIP: \_\_\_\_\_ Ownership is: Public  Private
5. Present Use: Residence Original Use: Residence  
 Other past uses: \_\_\_\_\_

DESCRIPTION

6. Briefly describe the present physical appearance of the site or structure and describe any major alterations from its original condition:

This streamline moderne styled house has a flat roof, round corners and a porthole window at the second floor. Abstracted classical detail decorates the entry and a regency finial graces the side gate.

The exterior walls are stucco on frame. In 1954 a 14 x 19 ft. second story addition was completed, and in 1983, some restoration and alteration occurred at the rear of the second story.

7. Locational sketch map (draw and label site and surrounding streets, roads, and prominent landmarks):

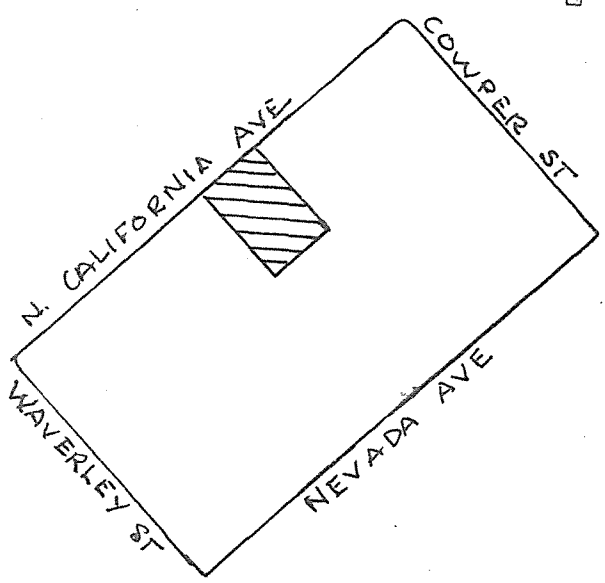
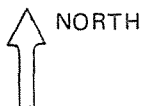

8. Approximate property size:  
 Lot size (in feet) Frontage 60.14  
 Depth 139.94  
 or approx. acreage \_\_\_\_\_
9. Condition: (check one)  
 a. Excellent  b. Good  c. Fair   
 d. Deteriorated  e. No longer in existence
10. Is the feature a. Altered?  b. Unaltered?
11. Surroundings: (Check more than one if necessary)  
 a. Open land  b. Scattered buildings   
 c. Densely built-up  d. Residential   
 e. Commercial  f. Industrial   
 g. Other
12. Threats to site:  
 a. None known  b. Private development   
 c. Zoning  d. Public Works project   
 e. Vandalism  f. Other
13. Date(s) of enclosed photograph(s): 1978

450 N. California

NOTE: The following (Items 14-19) are for structures only.

- 14. Primary exterior building material: a. Stone  b. Brick  c. Stucco  d. Adobe  e. Wood   
f. Other  \_\_\_\_\_
- 15. Is the structure: a. On its original site?  b. Moved?  c. Unknown?
- 16. Year of initial construction 1937 This date is: a. Factual  b. Estimated
- 17. Architect (if known): William F. Klay
- 18. Builder (if known): William F. Klay
- 19. Related features: a. Barn  b. Carriage house  c. Outhouse  d. Shed(s)  e. Formal garden(s)   
f. Windmill  g. Watertower/tankhouse  h. Other  \_\_\_\_\_ i. None

SIGNIFICANCE

20. Briefly state historical and/or architectural importance (include dates, events, and persons associated with the site when known):

This is a very fine example of an important style which is relatively rare in Palo Alto. It was built for Burl W. Brant and his wife Pamela; he was the sales manager of the Sutter Packing Company. From 1940-44, the owners were William B. and Marcella Wolken. Wolken managed the Island Club at the Golden Gate International Exposition, originated the Stanford Bowl, and operated the food concessions for football games at the University of California, Stanford, and San Jose State College. Maxwell A. and Floy Bloomfield owned the house from 1946 to 1976. A graduate of the New York University School of Business Administration, Bloomfield was the representative of Van Raalte Co. in the West.

- 21. Main theme of the historic resource: (Check only one): a. Architecture  b. Arts & Leisure   
c. Economic/Industrial  d. Exploration/Settlement  e. Government  f. Military   
g. Religion  h. Social/Education
- 22. Sources: List books, documents, surveys, personal interviews, and their dates:  
P.A. Times 4/3/37, 10/14/44, 12/14/79  
Assessor's Books, City Hall  
Polks City Directory; Interview 1985, William Klay
- 23. Date form prepared: 1978, 1985 By (name): Anne Nelson Huber; Historic Resources Board; P.A. Hist. Assn.  
Address: 250 Hamilton Ave City Palo Alto, Ca 94301 ZIP: \_\_\_\_\_  
Phone: \_\_\_\_\_ Organization: \_\_\_\_\_

(State Use Only)

HISTORIC RESOURCES INVENTORY

(State use only)  
 Ser \_\_\_\_\_ Site \_\_\_\_\_ Mo. \_\_\_\_\_ Yr. \_\_\_\_\_  
 UTM \_\_\_\_\_ Q \_\_\_\_\_ NR \_\_\_\_\_ SHL \_\_\_\_\_  
 Lat \_\_\_\_\_ Lon \_\_\_\_\_ Era \_\_\_\_\_ Sig \_\_\_\_\_  
 Adm \_\_\_\_\_ T2 \_\_\_\_\_ T3 \_\_\_\_\_ Cat \_\_\_\_\_ HABS \_\_\_\_\_ HAER \_\_\_\_\_ Fed \_\_\_\_\_

IDENTIFICATION Cat. III

- Common name: \_\_\_\_\_
- Historic name, if known: \_\_\_\_\_
- Street or rural address 2105, 2114, 2115, 2124 Oberlin Street  
 City: Palo Alto ZIP: \_\_\_\_\_ County Santa Clara  
Jewell McCann, 940 College, Menlo Park, Ca 94025  
 4. Present owner, if known: ~~John E. Todd, Joyce Parker~~ Address: ~~745 Materdoro St~~  
 City: Palo Alto, Ca 94306 ZIP: \_\_\_\_\_ Ownership is: Public  Private
- Present Use: Residences Original Use: Residences  
 Other past uses: \_\_\_\_\_

DESCRIPTION

- Briefly describe the present physical appearance of the site or structure and describe any major alterations from its original condition:

These two pairs of shingled cottages with boulder-work chimneys have unusual gable configurations. The units are placed on the sites in checkerboard fashion to create a private yard for each and enhance the feeling of expansiveness of the site. An addition at the front of 2115 intrudes into its neighbor's area and almost hides the original facade.

- Locational sketch map (draw and label site and surrounding streets, roads, and prominent landmarks):

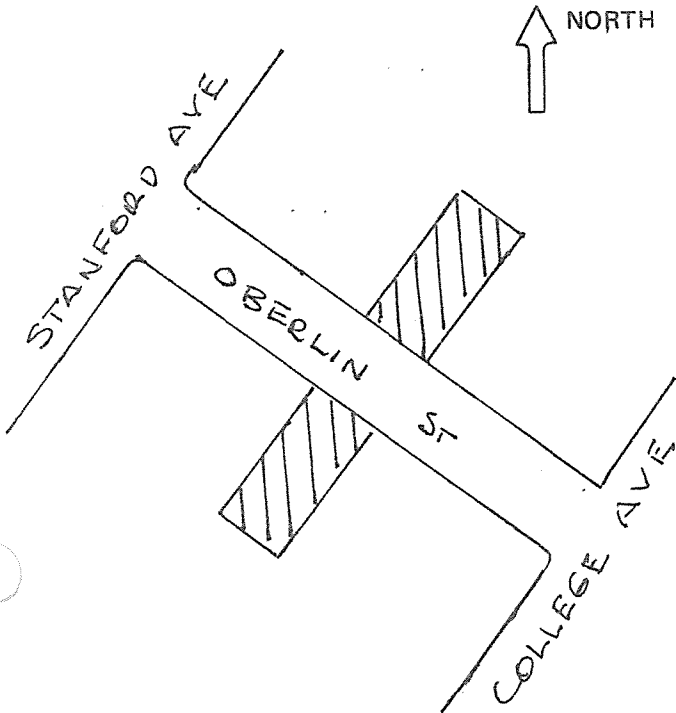

- Approximate property size:  
 Lot size (in feet) Frontage 54.5; 30  
 Depth 125;  
 or approx. acreage \_\_\_\_\_.
- Condition: (check one)  
 a. Excellent  b. Good  c. Fair   
 d. Deteriorated  e. No longer in existence
- Is the feature a. Altered?  b. Unaltered?
- Surroundings: (Check more than one if necessary)  
 a. Open land  b. Scattered buildings   
 c. Densely built-up  d. Residential   
 e. Commercial  f. Industrial   
 g. Other
- Threats to site:  
 a. None known  b. Private development   
 c. Zoning  d. Public Works project   
 e. Vandalism  f. Other
- Date(s) of enclosed photograph(s): 1978

NOTE: The following (Items 14-19) are for structures only.

14. Primary exterior building material: a. Stone  b. Brick  c. Stucco  d. Adobe  e. Wood   
 f. Other  \_\_\_\_\_
15. Is the structure: a. On its original site?  b. Moved?  c. Unknown?
16. Year of initial construction 1928 This date is: a. Factual  b. Estimated
17. Architect (if known): H. Van Polen
18. Builder (if known): H. Van Polen (owner and builder)
19. Related features: a. Barn  b. Carriage house  c. Outhouse  d. Shed(s)  e. Formal garden(s)   
 f. Windmill  g. Watertower/tankhouse  h. Other  \_\_\_\_\_ i. None

## SIGNIFICANCE

20. Briefly state historical and/or architectural importance (include dates, events, and persons associated with the site when known):

Attractive examples of Craftsman mode with unusual site planning.  
 The cottages resemble those built in the city much earlier in the century, and suggest the appeal of Craftsman rusticity where it already had been well established, notably Professorville but throughout the community's older districts. As rental units, the cottages housed numerous occupants, usually for relatively short periods of time.

21. Main theme of the historic resource: (Check only one): a. Architecture  b. Arts & Leisure   
 c. Economic/Industrial  d. Exploration/Settlement  e. Government  f. Military   
 g. Religion  h. Social/Education
22. Sources: List books, documents, surveys, personal interviews, and their dates: P.A. City Directories:  
 P.A. Times 7/31/28, 8/29/28, 12/8/28, 8/7/29

23. Date form prepared: 1978, 1985 By (name): Historic Resources Board; P.A. Hist. Assn.  
 Address: 250 Hamilton Ave City Palo Alto, Ca 94301 ZIP: \_\_\_\_\_  
 Phone: \_\_\_\_\_ Organization: \_\_\_\_\_

(State Use Only)



HISTORIC RESOURCES INVENTORY

(State use only)

Ser \_\_\_\_\_ Site \_\_\_\_\_ Mo. \_\_\_\_\_ Yr. \_\_\_\_\_  
 UTM \_\_\_\_\_ O \_\_\_\_\_ NR \_\_\_\_\_ SHL \_\_\_\_\_  
 Lat \_\_\_\_\_ Lon \_\_\_\_\_ Era \_\_\_\_\_ Sig \_\_\_\_\_  
 Adm \_\_\_\_\_ T2 \_\_\_\_\_ T3 \_\_\_\_\_ Cat \_\_\_\_\_ HABS \_\_\_\_\_ HAER \_\_\_\_\_ Fed \_\_\_\_\_

IDENTIFICATION Cat. IV

- Common name: \_\_\_\_\_
- Historic name, if known: \_\_\_\_\_
- Street or rural address 2130-2136 Oberlin Street (originally 530-536 Oberlin St.)  
 City: Palo Alto ZIP: \_\_\_\_\_ County: Santa Clara
- Present owner, if known: 2130: Robert and Margaret Finn Address: Same  
2136: Christopher Rafferty  
 City: \_\_\_\_\_ ZIP: \_\_\_\_\_ Ownership is: Public  Private
- Present Use: Residential Original Use: Residential  
 Other past uses: \_\_\_\_\_

DESCRIPTION

- Briefly describe the present physical appearance of the site or structure and describe any major alterations from its original condition:  
Careful handling of scale and detail distinguish this pair of Spanish Colonial Revival cottages with large arch windows, tile roofs, and shared driveway.

7. Locational sketch map (draw and label site and surrounding streets, roads, and prominent landmarks):

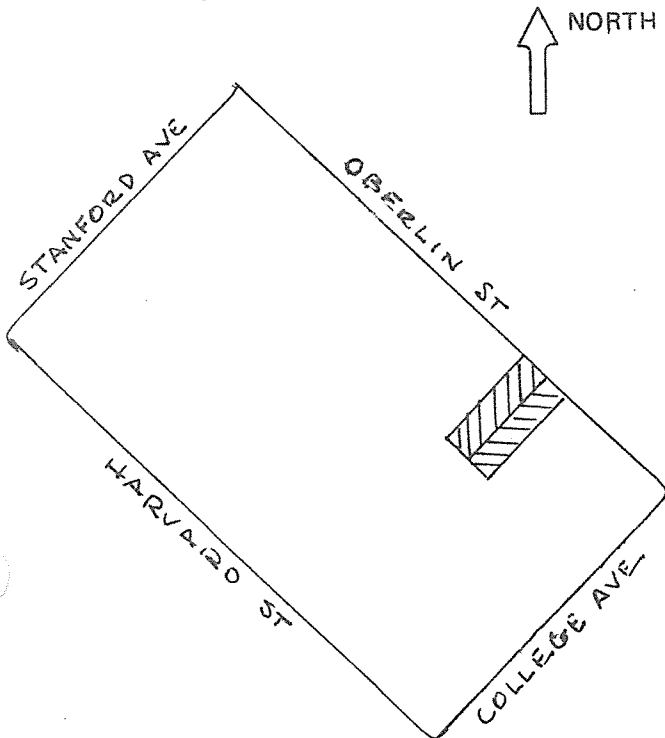

- Approximate property size:  
 Lot size (in feet) Frontage 25, 25  
 Depth 125, 125  
 or approx. acreage \_\_\_\_\_
- Condition: (check one)  
 a. Excellent  b. Good  c. Fair   
 d. Deteriorated  e. No longer in existence
- Is the feature a. Altered?  b. Unaltered?
- Surroundings: (Check more than one if necessary)  
 a. Open land  b. Scattered buildings   
 c. Densely built-up  d. Residential   
 e. Commercial  f. Industrial   
 g. Other
- Threats to site:  
 a. None known  b. Private development   
 c. Zoning  d. Public Works project   
 e. Vandalism  f. Other
- Date(s) of enclosed photograph(s): 1978

2130-2136 Oberlin

NOTE: The following (Items 14-19) are for structures only.

14. Primary exterior building material: a. Stone  b. Brick  c. Stucco  d. Adobe  e. Wood   
f. Other  \_\_\_\_\_
15. Is the structure: a. On its original site?  b. Moved?  c. Unknown?
16. Year of initial construction 1932 This date is: a. Factual  b. Estimated
17. Architect (if known): \_\_\_\_\_
18. Builder (if known): Ed Lewis (owner and builder)
19. Related features: a. Barn  b. Carriage house  c. Outhouse  d. Shed(s)  e. Formal garden(s)   
f. Windmill  g. Watertower/tankhouse  h. Other  \_\_\_\_\_ i. None

SIGNIFICANCE

20. Briefly state historical and/or architectural importance (include dates, events, and persons associated with the site when known):

This pair of cottages condenses the Spanish Colonial Revival style into a small package. They frequently have served as rental units, but since the 1940s they have been separately owned. Owners listed for 2130 include F.A. Shalon, (1941-50), Oliver Sweningsen (1950-4), and Mrs. Lulu C. Baker (1955-65); for 2136, Everett G. Sacyer (1946-7), and G.J. Ferguson (1949-?).

21. Main theme of the historic resource: (Check only one): a. Architecture  b. Arts & Leisure   
c. Economic/Industrial  d. Exploration/Settlement  e. Government  f. Military   
g. Religion  h. Social/Education

22. Sources: List books, documents, surveys, personal interviews, and their dates: P.A. City Directories; P.A. Building Dept. file; interview 1985, Margaret Finn; P.A. Times 8/12/32

23. Date form prepared: 1978, 1985 By (name): Historic Resources Board; P.A. Hist. Assn.  
Address: 250 Hamilton Ave City Palo Alto, Ca 94301 ZIP: \_\_\_\_\_  
Phone: \_\_\_\_\_ Organization: \_\_\_\_\_

(State Use Only)

333

(State use only)  
 Ser \_\_\_\_\_ Site \_\_\_\_\_ No. \_\_\_\_\_ Yr. \_\_\_\_\_  
 UTM \_\_\_\_\_ Q \_\_\_\_\_ NR \_\_\_\_\_ SHL \_\_\_\_\_  
 Lat \_\_\_\_\_ Lon \_\_\_\_\_ Era \_\_\_\_\_ Sig \_\_\_\_\_  
 Adm \_\_\_\_\_ T2 \_\_\_\_\_ T3 \_\_\_\_\_ Cat \_\_\_\_\_ HABS \_\_\_\_\_ HAER \_\_\_\_\_ Fed \_\_\_\_\_

**HISTORIC RESOURCES INVENTORY**

Category I of Historic Building Inventory  
City Council action on 3/30/87  
IDENTIFICATION

- Common name: Juana Briones House
- Historic name, if known: 4155 Site of home of Juana Briones, State Historic Landmark # 524
- Street or rural address: 4255 Old Adobe Rd.  
 City: Palo Alto ZIP: 94306 County: Santa Clara
- Present owner, if known: Susan Berthiaume (1/3 owner) Address: 4255 Old Adobe Rd.  
 City: Palo Alto ZIP: 94306 Ownership is: Public  Private
- Present Use: Residential Original Use: Residential  
 Other past uses: Residential (owned by only three families & descendents in 140 years)

**DESCRIPTION**

- Briefly describe the present physical appearance of the site or structure and describe any major alterations from its original condition:  
 The original structure, built in 1846 or '47, was long and narrow, similar to adobes constructed in the Spanish-Mexican period. It consisted then of three rooms, and remains so today. The original walls were a wooden cribe filled with adobe soil. They have been covered with cement to preserve and strengthen them. The location of doors and windows was changed in the 1900 to 1908 period. Two wings and a central courtyard were added in 1908. The wings are made of wood. The courtyard may have been constructed around an original well, and probably incorporates materials from the original building site. Parts of the structure have two stories. The attic of the original Mexican style building has been enlarged.

7. Locational sketch map (draw and label site and surrounding streets, roads, and prominent landmarks):

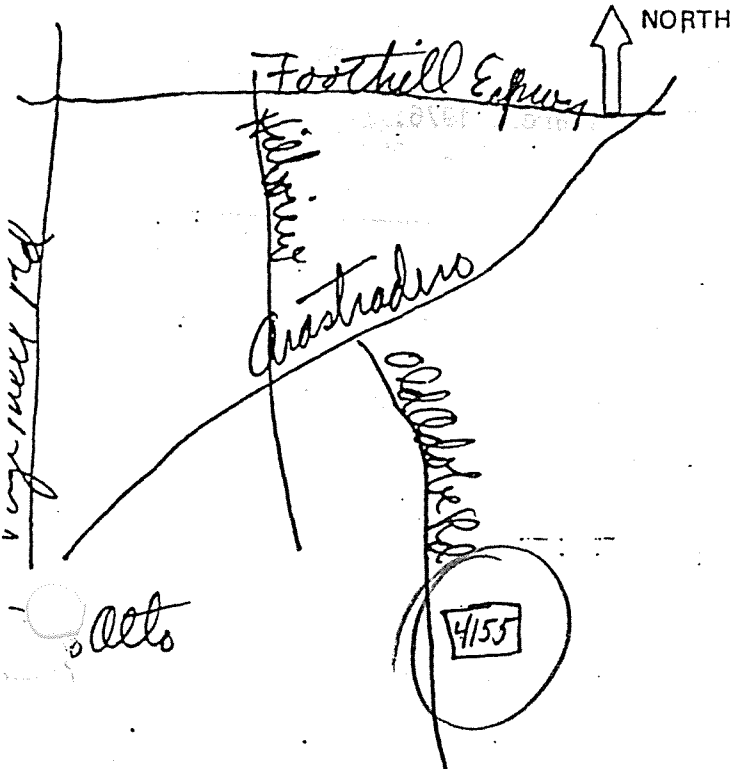

- Approximate property size:  
 Lot size (in feet) Frontage \_\_\_\_\_  
 Depth \_\_\_\_\_  
 or approx. acreage 1.5
- Condition: (check one)  
 a. Excellent  b. Good  c. Fair   
 d. Deteriorated  e. No longer in existence
- Is the feature a. Altered?  b. Unaltered?
- Surroundings: (Check more than one if necessary)  
 a. Open land  b. Scattered buildings   
 c. Densely built-up  d. Residential   
 e. Commercial  f. Industrial   
 g. Other
- Threats to site:  
 a. None known  b. Private development   
 c. Zoning  d. Public Works project   
 e. Vandalism  f. Other  demolition
- Date(s) of enclosed photograph(s): Polaroid 1/14/87

NOTE: The following (Items 14-19) are for structures only.

14. Primary exterior building material: a. Stone  b. Brick  c. Stucco  d. Adobe  e. Wood   
f. Other
15. Is the structure: a. On its original site?  b. Moved?  c. Unknown?
16. Year of initial construction 1847 This date is: a. Factual  b. Estimated
17. Architect (if known): ---
18. Builder (if known): ---
19. Related features: a. Barn  b. Carriage house  c. Outhouse  d. Shed(s)  e. Formal garden(s)   
f. Windmill  g. Watertower/tankhouse  h. Other  added sections are historically interesting i. None

SIGNIFICANCE

20. Briefly state historical and/or architectural importance (include dates, events, and persons associated with the site when known):

The oldest part of the structure has been lived in continuously for 140 years, and was constructed by Juana Briones de Miranda, the pre-eminent woman of the Spanish and Mexican period of California history. It was the main house on the 4,400 acre (one square league) Rancho La Purisima Concepcion, which she purchased in 1844 from its Indian owners. The Briones part of the house is thought to have been constructed in 1846 or '47. Juana Briones was born in the last decade of the 18th century in Monterey or Carmel and lived with her parents at the Mission Santa Clara. She enjoyed a growing reputation from her young adulthood through much of her life for her skill in the healing arts, and she is mentioned for this for her energy, her hospitality, and her compassion, in many accounts of California when virtually the only access was by boat or by rare visits by trappers. She made her living by farming and ranching, and showed herself to be wise in her land transactions, first in Yerba Buena (San Francisco) and later in what is now Palo Alto and Los Altos. Her descendents still can be found in the Bay Area. Subsequent owners preserved the original character of the Briones structure and the early California flavor.

21. Main theme of the historic resource: (Check only one): a. Architecture  b. Arts & Leisure   
c. Economic/Industrial  d. Exploration/Settlement  e. Government  f. Military   
g. Religion  h. Social/Education

22. Sources: List books, documents, surveys, personal interviews, and their dates:

Florence M. Fava, LOS ALTOS HILLS, Woodside, CA, Richards, 1976.  
Phyllis Butler, THE VALLEY OF SANTA CLARA, San Jose, Junior League, 1975.  
Dorothy Regnery, Files of Calif. Historical Resources Commission, Landmark # 524, 1970.

23. Date form prepared: 1/14/87 By (name): Jeanne McDonnell  
Address: 1509 Portola Avenue City Palo Alto ZIP: 94306  
Phone: (415) 321 5260 Organization: Women's Heritage Museum

(State Use Only)

HISTORIC RESOURCES INVENTORY

(State use only)  
 UTM \_\_\_\_\_ Q \_\_\_\_\_ NR \_\_\_\_\_ SHL \_\_\_\_\_  
 Lat \_\_\_\_\_ Lon \_\_\_\_\_ Era \_\_\_\_\_ Sig \_\_\_\_\_  
 Adm \_\_\_\_\_ T2 \_\_\_\_\_ T3 \_\_\_\_\_ Cat \_\_\_\_\_ HABS \_\_\_\_\_ HAER \_\_\_\_\_ Fed \_\_\_\_\_

IDENTIFICATION Cat. II

1. Common name: \_\_\_\_\_
2. Historic name, if known: Kiler House
3. Street or rural address 1184 Palo Alto Avenue  
 City: Palo Alto ZIP: \_\_\_\_\_ County: Santa Clara
4. Present owner, if known: Patricia Evans and Charles F. Weiss Address: Same  
 City: \_\_\_\_\_ ZIP: \_\_\_\_\_ Ownership is: Public  Private
5. Present Use: Residential Original Use: Residential  
 Other past uses: \_\_\_\_\_

DESCRIPTION

6. Briefly describe the present physical appearance of the site or structure and describe any major alterations from its original condition:

A large L-shaped Spanish Colonial Revival house; its street facade is almost unfenestrated, while the rear opens to an enclosed garden. The garden, the unusual decorative band of brick work at the eaves, and other elements of design reflect Moorish originals which the first owners studied in Spain. Construction began in 1931 with the studio; the main building was completed in 1935.

7. Locational sketch map (draw and label site and surrounding streets, roads, and prominent landmarks):

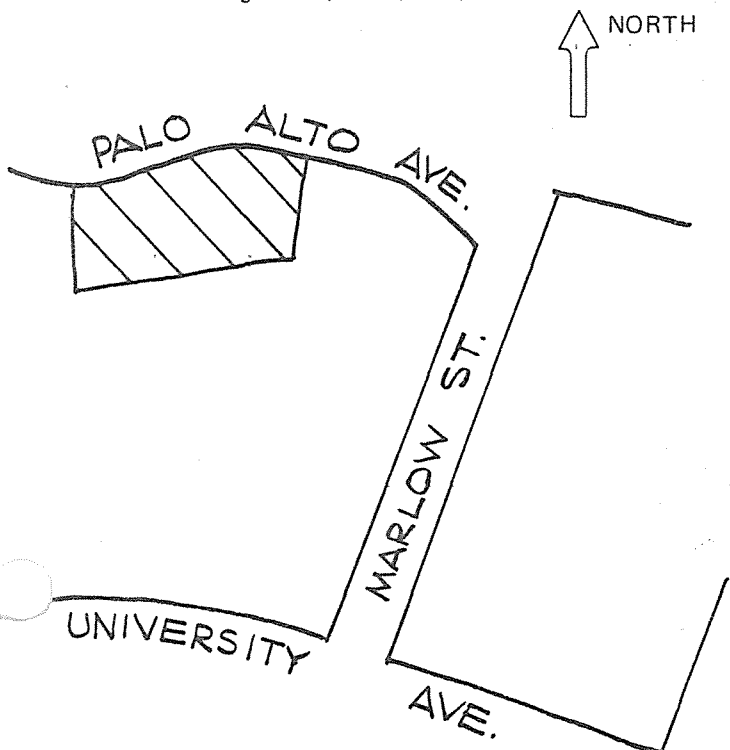

8. Approximate property size:  
 Lot size (in feet) Frontage 206.28  
 Depth 85.20  
 or approx. acreage \_\_\_\_\_
9. Condition: (check one)  
 a. Excellent  b. Good  c. Fair   
 d. Deteriorated  e. No longer in existence
10. Is the feature a. Altered?  b. Unaltered?
11. Surroundings: (Check more than one if necessary)  
 a. Open land  b. Scattered buildings   
 c. Densely built-up  d. Residential   
 e. Commercial  f. Industrial   
 g. Other
12. Threats to site:  
 a. None known  b. Private development   
 c. Zoning  d. Public Works project   
 e. Vandalism  f. Other
13. Date(s) of enclosed photograph(s): 1978

1184 Palo Alto

NOTE: The following (Items 14-19) are for structures only.

14. Primary exterior building material: a. Stone  b. Brick  c. Stucco  d. Adobe  e. Wood   
f. Other
15. Is the structure: a. On its original site?  b. Moved?  c. Unknown?
16. Year of initial construction 1935 This date is: a. Factual  b. Estimated
17. Architect (if known): Charles K. Sumner (1874-1948)
18. Builder (if known): Black and Campbell, 1931; E.J. Schmaling, 1935
19. Related features: a. Barn  b. Carriage house  c. Outhouse  d. Shed(s)  e. Formal garden(s)   
f. Windmill  g. Watertower/tankhouse  h. Other  i. None

SIGNIFICANCE

20. Briefly state historical and/or architectural importance (include dates, events, and persons associated with the site when known):

The structure is a superb example of the style from the hand of a major Palo Alto architect. It was built for E. Leslie Kiler and his wife Chrysella (nee Dunker). Kiler was a major landscape architect in Palo Alto and at Stanford University in the late 1920s and the 1930s. After service in the U.S. Air Force during World War II, he became a painter in Santa Barbara and Carmel. The house was sold in 1942 to Nina M. Foley (widow of J.B. Foley), and, six years later, to Mrs. Hazel D. Burtis (widow of Prentice T. Burtis). She occupied it until 1967, when it was acquired by Patricia Evans.

21. Main theme of the historic resource: (Check only one): a. Architecture  b. Arts & Leisure   
c. Economic/Industrial  d. Exploration/Settlement  e. Government  f. Military   
g. Religion  h. Social/Education

22. Sources: List books, documents, surveys, personal interviews, and their dates:

P.A. Times 7/22/31  
Palo Alto City Directories; Sunset, 128, No. 4 (April 1962), 106-7; interview with E. Leslie Kiler, April 1981.

23. Date form prepared: 1981, 1985 By (name): Historic Resources Board ; P.A. Hist. Assn.  
Address: 250 Hamilton Ave City Palo Alto, Ca 94301 ZIP: \_\_\_\_\_  
Phone: \_\_\_\_\_ Organization: \_\_\_\_\_

(State Use Only)

HISTORIC RESOURCES INVENTORY

(State use only)  
 Ser \_\_\_\_\_ Site \_\_\_\_\_ Mo. \_\_\_\_\_ Yr. \_\_\_\_\_  
 UTM \_\_\_\_\_ Q \_\_\_\_\_ NR \_\_\_\_\_ SHL \_\_\_\_\_  
 Lat \_\_\_\_\_ Lon \_\_\_\_\_ Era \_\_\_\_\_ Sig \_\_\_\_\_  
 Adm \_\_\_\_\_ T2 \_\_\_\_\_ T3 \_\_\_\_\_ Cat \_\_\_\_\_ HABS \_\_\_\_\_ HAER \_\_\_\_\_ Fed \_\_\_\_\_

IDENTIFICATION Cat. III

1. Common name: \_\_\_\_\_
2. Historic name, if known: \_\_\_\_\_
3. Street or rural address 1795 Park Boulevard (early addresses, 280, 191, 195 Park Blvd)  
 City: Palo Alto ZIP: \_\_\_\_\_ County: Santa Clara
4. Present owner, if known: August J. and Mary R. Ramberg Address: Same  
 City: \_\_\_\_\_ ZIP: \_\_\_\_\_ Ownership is: Public  Private
5. Present Use: Residence Original Use: Residence  
 Other past uses: Apartments

DESCRIPTION

6. Briefly describe the present physical appearance of the site or structure and describe any major alterations from its original condition:

A lesson in the power of ornament, this building is a fine example of the Georgian Revival style.

7. Locational sketch map (draw and label site and surrounding streets, roads, and prominent landmarks):

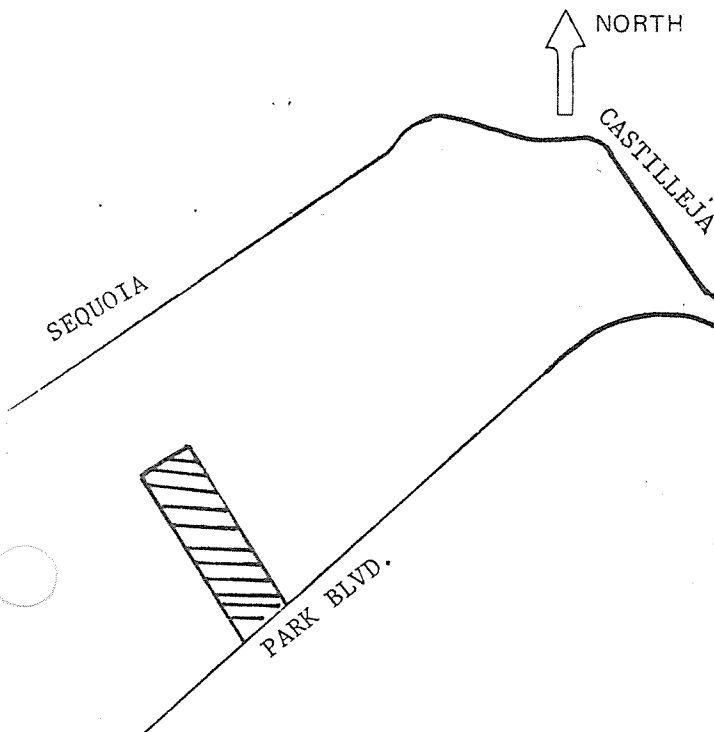

8. Approximate property size:

Lot size (in feet) Frontage 50  
 Depth 173;  
 or approx. acreage \_\_\_\_\_

9. Condition: (check one)

- a. Excellent  b. Good  c. Fair   
 d. Deteriorated  e. No longer in existence

10. Is the feature a. Altered?  b. Unaltered?

11. Surroundings: (Check more than one if necessary)

- a. Open land  b. Scattered buildings   
 c. Densely built-up  d. Residential   
 e. Commercial  f. Industrial   
 g. Other

12. Threats to site:

- a. None known  b. Private development   
 c. Zoning  d. Public Works project   
 e. Vandalism  f. Other

13. Date(s) of enclosed photograph(s): 1978

1795 Park Blvd.

NOTE: The following (Items 14-19) are for structures only.

14. Primary exterior building material: a. Stone  b. Brick  c. Stucco  d. Adobe  e. Wood   
f. Other
15. Is the structure: a. On its original site?  b. Moved?  c. Unknown?
16. Year of initial construction 1904 This date is: a. Factual  b. Estimated
17. Architect (if known): C.E. Branson? \*
18. Builder (if known): L.S. Bean? \*
19. Related features: a. Barn  b. Carriage house  c. Outhouse  d. Shed(s)  e. Formal garden(s)   
f. Windmill  g. Watertower/tankhouse  h. Other  i. None

SIGNIFICANCE

20. Briefly state historical and/or architectural importance (include dates, events, and persons associated with the site when known):

The austerity of the building's simple rectangular form is both eased and given authority by the prominent ornamentation of the entry portico and other classically-derived detailing. It was one of the large homes built in conjunction with the opening of Evergreen Park real estate in 1904 and was featured in the display advertisement of early 1905 published by the Co-Operative Land and Trust Co. In late 1906 it was purchased by Henrietta Reed who, with O.K., Harry, and Marguerite, occupied it until the time of World War I. When they moved to Southern California, they sold the house to Charles C. and Emma Baughman, whose home it was until 1934. Baughman was an employee of Southern Pacific railroad. From 1934 to 1942, it was occupied by Professor John Hedberg and his family. He served on the Stanford faculty in civil engineering until his sudden death, age 35, in 1942. Between the occupancy of Mrs. Mamie C. Robinson and her family in the late 'forties and the 'fifties, and the early 1980s it was converted to apartments. It was restored to single-family use by the present owners in 1981.

21. Main theme of the historic resource: (Check only one): a. Architecture  b. Arts & Leisure   
c. Economic/Industrial  d. Exploration/Settlement  e. Government  f. Military   
g. Religion  h. Social/Education
22. Sources: List books, documents, surveys, personal interviews, and their dates: P.A. City Directories; P.A. Times 3/2/05, 5/1/06, 8/3/42, 9/11/44; U.S. Census 1910, ED 75, p. 7; Book 321 (Deeds), p. 412-3, 11/17/06; Book 321 (Deeds), p. 417-8, 3/7/07; Book 439 (Deeds), p. 461, 2/19/16; Book 703 (Off. Rec.), p. 48, 7/20/34 (Santa Clara Co. Recorder); interviews 1981, Mary R. Ramberg, Jules Arjo
23. Date form prepared: 1981, 1986 By (name): Historic Resources Board; P.A. Hist. Assn.  
Address: 250 Hamilton Ave City Palo Alto, Ca 94301 ZIP: \_\_\_\_\_  
Phone: \_\_\_\_\_ Organization: \_\_\_\_\_

(State Use Only)

\*L.S. Bean has been identified as builder of other houses in Evergreen Park and College Terrace at this time; the Ionic order of capital used here and at the house he built in 1906 at 505 Homer Avenue rarely appears in Palo Alto buildings of the era, and both houses display exceptionally prominent emphasis on classical detailing. The architect at 505 Homer Avenue was C.E. Branson, then city Building Inspector.



HISTORIC RESOURCES INVENTORY

Site No. \_\_\_\_\_ Site \_\_\_\_\_ Mo. \_\_\_\_\_ Yr. \_\_\_\_\_  
 UTM \_\_\_\_\_ O \_\_\_\_\_ NR \_\_\_\_\_ SHL \_\_\_\_\_  
 Lat \_\_\_\_\_ Lon \_\_\_\_\_ Era \_\_\_\_\_ Sig \_\_\_\_\_  
 Adm. T2 \_\_\_\_\_ T3 \_\_\_\_\_ Cat. HABS \_\_\_\_\_ HAER \_\_\_\_\_ Fed \_\_\_\_\_

IDENTIFICATION: CAT. 2 (CC approved 5/14/88)

1. Common name: \_\_\_\_\_
2. Historic name, if known: \_\_\_\_\_
3. Street or rural address: 2110 Park Boulevard  
 City: Palo Alto, CA ZIP: \_\_\_\_\_ County: Santa Clara
4. Present owner, if known: Calvin Arrington Address: same  
 City: \_\_\_\_\_ ZIP: \_\_\_\_\_ Ownership is: Public  Private
5. Present Use: Residence Original Use: Residence  
 Other past uses: \_\_\_\_\_

DESCRIPTION

6. Briefly describe the present physical appearance of the site or structure and describe any major alterations from its original condition:

This reinforced concrete house is a free adaptation of Mission Revival devices and forms. An inventive building, both structurally and visually, in its original state the roof area was developed as a trellised terrace. A red tile roof covers the entry porch. Some of the recessed windows feature criss-cross iron detailing. This house was built to demonstrate fire and earthquake resistant features as well as to show that handsome and regionally popular architectural qualities were compatible with concrete.

7. Locational sketch map (draw and label site and surrounding streets, roads, and prominent landmarks):

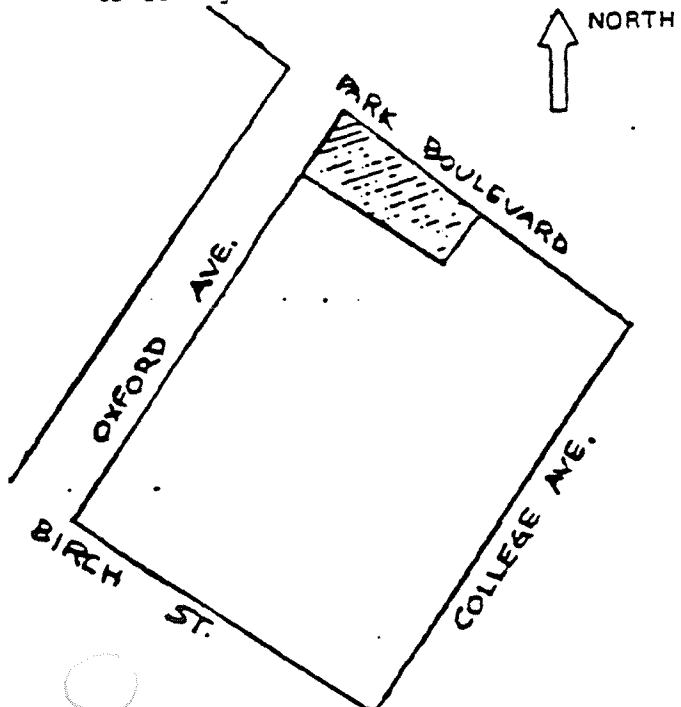

APR -- 5 1988

8. Approximate property size:

Lot size (in feet) Frontage 140.53  
 Depth 65.95  
 or approx. acreage \_\_\_\_\_

9. Condition: (check one)

- a. Excellent  b. Good  c. Fair   
 d. Deteriorated  e. No longer in existence

10. Is the feature a. Altered?  b. Unaltered?

11. Surroundings: (Check more than one if necessary)

- a. Open land  b. Scattered buildings   
 c. Densely built-up  d. Residential   
 e. Commercial  f. Industrial   
 g. Other

12. Threats to site:

- a. None known  b. Private development   
 c. Zoning  d. Public Works project   
 e. Vandalism  f. Other

13. Date(s) of professional observation: 1978

NOTE: The following (Items 14-19) are for structures only.

14. Primary exterior building material: a. Stone  b. Brick  c. Stucco  d. Adobe  e. Wood   
f. Other  Concrete
15. Is the structure: a. On its original site?  b. Moved?  c. Unknown?
16. Year of initial construction 1909 This date is: a. Factual  b. Estimated
17. Architect (if known): W. Garden Mitchell
18. Builder (if known): P.W. Bosworth of San Francisco Concrete Building Construction
19. Related features: a. Barn  b. Carriage house  c. Outhouse  d. Shed(s)  e. Formal garden(s)   
f. Windmill  g. Watertower/tankhouse  h. Other  i. None

#### SIGNIFICANCE

20. Briefly state historical and/or architectural importance (include dates, events, and persons associated with the site when known):

This house is important architecturally as an impressive and fanciful attempt to expand the possibilities of the Mission Revival and technologically significant in its use of reinforced concrete for a residential structure. The house was described in an early book on the residential usage of reinforced concrete. It was built and offered as one of the prizes in a contest run by the San Francisco Bulletin. (Another similar house in Half Moon Bay was another prize). Patricia O'Hair of San Francisco, the winner, rented out the house until 1918. In 1928 Mrs. Minerva Halliday, born several months before the Emancipation Proclamation (1863) in Jackson, Miss., bought the house. She also purchased a similar house built for the owner of the S.F. Bulletin in 1910 at 1705 El Camino (demolished in 1957). The house was deeded to Mrs. Halliday's daughter, Mrs. Helen Wright in 1934.

21. Main theme of the historic resource: (Check only one): a. Architecture  b. Arts & Leisure   
c. Economic/Industrial  d. Exploration/Settlement  e. Government  f. Military   
g. Religion  h. Social/Education

22. Sources: List books, documents, surveys, personal interviews, and their dates:

Palo Alto Historical Association files

23. Date form prepared: 1978/1987 By (name): Gail Wooley/ Historical Resources Board  
Address: 250 Hamilton Avenue City: \_\_\_\_\_ ZIP: \_\_\_\_\_  
Phone: \_\_\_\_\_ Organization: \_\_\_\_\_

(State Use Only)

APR - 5 1988

NOTE: The following (Items 14-19) are for structures only.

4. Primary exterior building material: a. Stone  b. Brick  c. Stucco  d. Adobe  e. Wood   
 f. Other  \_\_\_\_\_
15. Is the structure: a. On its original site?  b. Moved?  c. Unknown?
16. Year of initial construction \_\_\_\_\_ This date is: a. Factual  b. Estimated
17. Architect (if known): \_\_\_\_\_
18. Builder (if known): \_\_\_\_\_
19. Related features: a. Barn  b. Carriage house  c. Outhouse  d. Shed(s)  e. Formal garden(s)   
 f. Windmill  g. Watertower/tankhouse  h. Other  \_\_\_\_\_ i. None

SIGNIFICANCE

20. Briefly state historical and/or architectural importance (include dates, events, and persons associated with the site when known):

2110 Park Blvd, continued:

\*\*\*#20, continued: subscription contest of 1909 was also a concrete house designed by Mitchell and built by Bosworth in Half Moon Bay. It evidently pleased R.A. Crothers, owner of the Bulletin, for in 1910 he had Bosworth build a house of the same design but twice as large at 1705 El Camino Real. It was lavishly fitted inside with oak and mahogany, marble, and ornamental sculpture and moldings by O.S. Sarsi of San Francisco. The Bulletin announced its value at \$15,000 when it was to be placed on the market. However, Crothers kept the house (although he himself did not occupy it) until 1926. It then was sold to Mrs. Halliday at the time she purchased the house at 2110 Park Blvd. Mrs. Halliday also deeded it to her daughter, Helen, in April, 1941, a few days before Mrs. Halliday's death. It was demolished in 1957. A deplorable instance of racial attitudes emerged in connection with the two houses. Six months after Mrs. Halliday's death, most of the Evergreen Park property owners signed a covenant against occupation of their property by persons—except servants—not of the white race.)

\*\*\* Sources continued: Book 482 (Deeds), p. 65, 11/30/18; Book 483 (Deeds), p. 200, 3/29/19; Book 32 (Off. Rec.), p. 562, 7/3/23; Book 42 (Off. Rec.), p. 236, 8/1/23; Book 230 (Off. Rec.), p. 514, 4/9/26; Book 239 (Off. Rec.), p. 294-9, 4/29/26; Book 1093 (Off. Rec.), p. 187-8, 10/11/34; Book 1093 (Off. Rec.), p. 192, 4/20/42; Book 272 (Off. Rec.), p. 247, 9/22/26; Book 1119 (Off. Rec.), p. 332-8, 10/20/41; interview 1986, Calvin Arrington

(State use only)  
 Ser \_\_\_\_\_ Site \_\_\_\_\_ Mo. \_\_\_\_\_ Yr. \_\_\_\_\_  
 UTM \_\_\_\_\_ Q \_\_\_\_\_ NR \_\_\_\_\_ SHL \_\_\_\_\_  
 Lat \_\_\_\_\_ Lon \_\_\_\_\_ Era \_\_\_\_\_ Sig \_\_\_\_\_  
 Adm \_\_\_\_\_ T2 \_\_\_\_\_ T3 \_\_\_\_\_ Cat \_\_\_\_\_ HABS \_\_\_\_\_ HAER \_\_\_\_\_ Fed \_\_\_\_\_

**HISTORIC RESOURCES INVENTORY**

**IDENTIFICATION Cat. IV**

1. Common name: \_\_\_\_\_
2. Historic name, if known: \_\_\_\_\_
3. Street or rural address: 1230 Parkinson Avenue  
 City: Palo Alto ZIP: \_\_\_\_\_ County: Santa Clara
4. Present owner, if known: H.L. and Ruth Cornelius Address: Same  
 City: \_\_\_\_\_ ZIP: \_\_\_\_\_ Ownership is: Public  Private
5. Present Use: Residential Original Use: Residential  
 Other past uses: \_\_\_\_\_

**DESCRIPTION**

6 Briefly describe the present physical appearance of the site or structure and describe any major alterations from its original condition:

This small, L-shaped cottage features a low-sweeping roof at the entrance and a bull's-eye window.

7. Locational sketch map (draw and label site and surrounding streets, roads, and prominent landmarks):

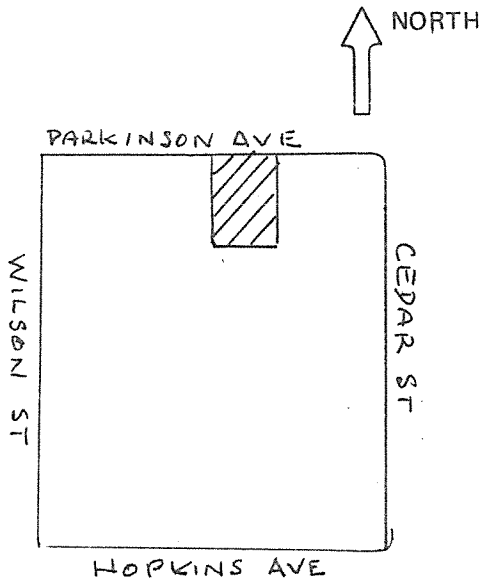

8. Approximate property size:

Lot size (in feet) Frontage 50  
 Depth 100  
 or approx. acreage \_\_\_\_\_

9. Condition: (check one)

- a. Excellent  b. Good  c. Fair   
 d. Deteriorated  e. No longer in existence

10. Is the feature a. Altered?  b. Unaltered?

11. Surroundings: (Check more than one if necessary)

- a. Open land  b. Scattered buildings   
 c. Densely built-up  d. Residential   
 e. Commercial  f. Industrial   
 g. Other

12. Threats to site:

- a. None known  b. Private development   
 c. Zoning  d. Public Works project   
 e. Vandalism  f. Other

13. Date(s) of enclosed photograph(s): 1978

1230 Parkinson

NOTE: The following (Items 14-19) are for structures only.

14. Primary exterior building material: a. Stone  b. Brick  c. Stucco  d. Adobe  e. Wood   
f. Other  \_\_\_\_\_
15. Is the structure: a. On its original site?  b. Moved?  c. Unknown?
16. Year of initial construction 1928 This date is: a. Factual  b. Estimated
17. Architect (if known): \_\_\_\_\_
18. Builder (if known): W.G. Bell (owner and builder) (W.J. Burnett?--see below)
19. Related features: a. Barn  b. Carriage house  c. Outhouse  d. Shed(s)  e. Formal garden(s)   
f. Windmill  g. Watertower/tankhouse  h. Other  \_\_\_\_\_ i. None

SIGNIFICANCE

20. Briefly state historical and/or architectural importance (include dates, events, and persons associated with the site when known):

The cottage illustrates the way that skillful management of scale and detail produce a strong visual effect, particularly in the slope and intersection of the roofs. The houses at 1230, 1240, and 1250 Parkinson were all built for W.G. Bell. The builder for 1250 Parkinson (originally 155 Cedar) was W.J. Burnett, in 1929.

At 1230 Parkinson, the first owner was Alf L. Gausewitz, an attorney, but by 1931 the house was a rental unit with numerous short-term occupants until 1948, when it was acquired by the present owners.

21. Main theme of the historic resource: (Check only one): a. Architecture  b. Arts & Leisure   
c. Economic/Industrial  d. Exploration/Settlement  e. Government  f. Military   
g. Religion  h. Social/Education

22. Sources: List books, documents, surveys, personal interviews, and their dates: P.A. City Directories; Dallas Wood, History of Palo Alto, 290; interview 1985, H.L. Cornelius P.A. Times 9/8/28, 9/21/29, 10/23/29

23. Date form prepared: 1978, 1985 By (name): Gail Woolley; Historic Resources Board; P.A. Hist. Assn.  
Address: 250 Hamilton Ave City: Palo Alto, Ca 94301 ZIP: \_\_\_\_\_  
Phone: \_\_\_\_\_ Organization: \_\_\_\_\_

(State Use Only)

HISTORIC RESOURCES INVENTORY

(State use only)  
 Ser \_\_\_\_\_ Site \_\_\_\_\_ Mo. \_\_\_\_\_ Yr. \_\_\_\_\_  
 UTM \_\_\_\_\_ O \_\_\_\_\_ NR \_\_\_\_\_ SHL \_\_\_\_\_  
 Lat \_\_\_\_\_ Lon \_\_\_\_\_ Era \_\_\_\_\_ Sig \_\_\_\_\_  
 Adm \_\_\_\_\_ T2 \_\_\_\_\_ T3 \_\_\_\_\_ Cat \_\_\_\_\_ HABS \_\_\_\_\_ HAER \_\_\_\_\_ Fed \_\_\_\_\_

IDENTIFICATION Cat. III

1. Common name: \_\_\_\_\_
2. Historic name, if known: \_\_\_\_\_
3. Street or rural address 347 Ramona Street  
 City: Palo Alto ZIP: \_\_\_\_\_ County: Santa Clara
4. Present owner, if known: Kermit Knopf Address: 930 Palo Alto Avenue  
 City: Palo Alto, Ca 94301 ZIP: \_\_\_\_\_ Ownership is: Public  Private
5. Present Use: Commercial Original Use: Residential  
 Other past uses: Apartments

DESCRIPTION

6. Briefly describe the present physical appearance of the site or structure and describe any major alterations from its original condition:

This building is a good example of a restrained Queen Anne design.

7. Locational sketch map (draw and label site and surrounding streets, roads, and prominent landmarks):

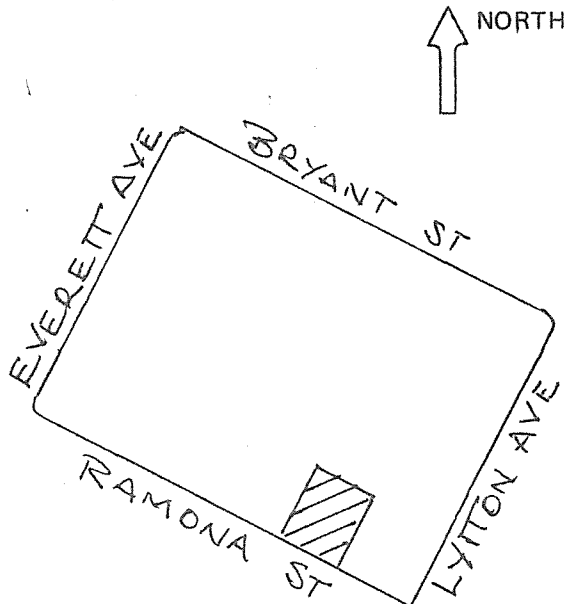

8. Approximate property size:

Lot size (in feet) Frontage 54  
 Depth 63  
 or approx. acreage \_\_\_\_\_

9. Condition: (check one)

- a. Excellent  b. Good  c. Fair   
 d. Deteriorated  e. No longer in existence

10. Is the feature a. Altered?  b. Unaltered?   
Outside stairs added 1923.

11. Surroundings: (Check more than one if necessary)

- a. Open land  b. Scattered buildings   
 c. Densely built-up  d. Residential   
 e. Commercial  f. Industrial   
 g. Other

12. Threats to site:

- a. None known  b. Private development   
 c. Zoning  d. Public Works project   
 e. Vandalism  f. Other

13. Date(s) of enclosed photograph(s): 1978

NOTE: The following (Items 14-19) are for structures only.

14. Primary exterior building material: a. Stone  b. Brick  c. Stucco  d. Adobe  e. Wood   
 f. Other  \_\_\_\_\_
15. Is the structure: a. On its original site?  b. Moved?  c. Unknown?
16. Year of initial construction 1893 This date is: a. Factual  b. Estimated
17. Architect (if known): \_\_\_\_\_
18. Builder (if known): Field and Ledyard (possible: M.P. Madison)
19. Related features: a. Barn  b. Carriage house  c. Outhouse  d. Shed(s)  e. Formal garden(s)   
 f. Windmill  g. Watertower/tankhouse  h. Other  \_\_\_\_\_ i. None

## SIGNIFICANCE

20. Briefly state historical and/or architectural importance (include dates, events, and persons associated with the site when known):

A two-story house with idiosyncratic turned columns and circular window in the second floor at one side. A patterned shingle surface differentiates the second floor from the shiplap-sheathed first floor. The house was built for W.W. Truesdale, who, in 1893, owned property in this and two other blocks in the city (but not in the block where a building is erroneously listed for him in the P.A. Times reports for 1893 construction). Truesdale and his wife Emeline were early residents, who built their family home at 327 Lytton Avenue in 1895 (M.P. Madison, contractor). Among the city offices he held were town marshal, tax collector, street superintendent, and trustee. Few tenants of the rental property stayed for more than a year, and in 1922 it became an apartment house (Ramona Apartments, Park Apartments). Commercial offices and studios were included from 1948 onward, including the studio of Elise and Roland Wolfe, well-established local photographers.

21. Main theme of the historic resource: (Check only one): a. Architecture  b. Arts & Leisure   
 c. Economic/Industrial  d. Exploration/Settlement  e. Government  f. Military   
 g. Religion  h. Social/Education
22. Sources: List books, documents, surveys, personal interviews, and their dates: P.A. City Directories; P.A. Assessor's Books, 1894-1900; P.A. Times 1/5/94, 1/2/96, 3/3/20, 1/1/24
23. Date form prepared: 1978, 1986 By (name): Chelo Rojas; Historic Resources Board; P.A. Hist. Assn.  
 Address: 250 Hamilton Ave City Palo Alto, Ca 94301 ZIP: \_\_\_\_\_  
 Phone: \_\_\_\_\_ Organization: \_\_\_\_\_

(State Use Only)

HISTORIC RESOURCES INVENTORY

"Addition"

(State use only)  
UTM \_\_\_\_\_ Q \_\_\_\_\_ NR \_\_\_\_\_ SHL \_\_\_\_\_  
Lat \_\_\_\_\_ Lon \_\_\_\_\_ Era \_\_\_\_\_ Sig \_\_\_\_\_  
Adm \_\_\_\_\_ T2 \_\_\_\_\_ T3 \_\_\_\_\_ Cat \_\_\_\_\_ HABS \_\_\_\_\_ HAER \_\_\_\_\_ Fed \_\_\_\_\_

CLASSIFICATION Cat. I

(CC approved 3-4-85)

(120-26-069)

1. Common name: \_\_\_\_\_
2. Historic name, if known: Gotham Shop (520 Ramona)
3. Street or rural address: 520-526 Ramona (Ramona Street Architectural District)  
City: Palo Alto ZIP: \_\_\_\_\_ County: \_\_\_\_\_
4. Present owner, if known: De Lemos Properties Address: PO Box 555  
City: Palo Alto ZIP: 94302 Ownership is: Public  Private
5. Present Use: Business District Original Use: \_\_\_\_\_  
Other past uses: \_\_\_\_\_

DESCRIPTION

6. Briefly describe the present physical appearance of the site or structure and describe any major alterations from its original condition:

The structure is an irregularly massed, one- to three-story complex with Bechelder tile, pieces of older buildings, interesting roof composition, and three strongly over-scaled dormers. The street-front building was reconstructed in 1985 to provide additional strength against earthquakes, the ancient, but dying, courtyard oak was removed, and other portions of the complex were carefully rehabilitated to retain as much as possible of the original design and character. The picturesque commercial block demonstrates Pedro de Lemos's highly personal Spanish Colonial Revival idiom.

7. Locational sketch map (draw and label site and surrounding streets, roads, and prominent landmarks):

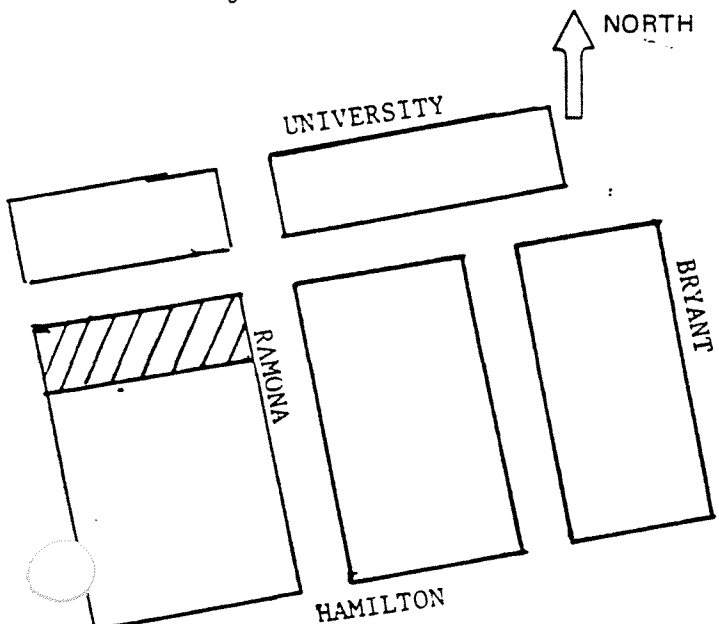

8. Approximate property size:

Lot size (in feet) Frontage 80, 50  
Depth 100, 100  
or approx. acreage \_\_\_\_\_

9. Condition: (check one)

- a. Excellent  b. Good  c. Fair   
d. Deteriorated  e. No longer in existence

10. Is the feature a. Altered?  b. Unaltered?

11. Surroundings: (Check more than one if necessary)

- a. Open land  b. Scattered buildings   
c. Densely built-up  d. Residential   
e. Commercial  f. Industrial   
g. Other

12. Threats to site:

- a. None known  b. Private development   
c. Zoning  d. Public Works project   
e. Vandalism  f. Other

13. Date(s) of enclosed photograph(s): 1978



NOTE: The following (Items 14-19) are for structures only.

14. Primary exterior building material: a. Stone  b. Brick  c. Stucco  d. Adobe  e. Wood   
 f. Other  \_\_\_\_\_
15. Is the structure: a. On its original site?  b. Moved?  c. Unknown?
16. Year of initial construction 1925 This date is: a. Factual  b. Estimated
17. Architect (if known): Pedro Lemos
18. Builder (if known): Damant and Sons
19. Related features: a. Barn  b. Carriage house  c. Outhouse  d. Shed(s)  e. Formal garden(s)   
 f. Windmill  g. Watertower/tankhouse  h. Other  \_\_\_\_\_ i. None

SIGNIFICANCE

20. Briefly state historical and/or architectural importance (include dates, events, and persons associated with the site when known):

Pedro Lemos, curator of the Stanford Museum, designed the Gotham Shop at 520 Ramona Street and later the building directly across the street. His talent as a craftsman as well as an architect is greatly in evidence here as it is in the Allied Arts buildings which he also designed. He emphasized and integrated color, texture, and line in each detail of his work -- concrete sidewalks, carved doors, wrought iron balconies, handmade tile roofs, and small patios and fountains.

The structure surrounds a courtyard in which a native live oak grew, an innovative union of nature and architecture which Palo Altoans of his era called ridiculous.

Relics from the 1906 earthquake, salvaged from the Stanford campus, add interest to the courtyard entrance.

The entire 500 block of Ramona is lined with mutually supportive Spanish Colonial Revival structures, some of them containing interior courtyards. The most significant examples are designed by Pedro de Lemos or by Birge Clarke.

21. Main theme of the historic resource: (Check only one): a. Architecture  b. Arts & Leisure   
 c. Economic/Industrial  d. Exploration/Settlement  e. Government  f. Military   
 g. Religion  h. Social/Education

22. Sources: List books, documents, surveys, personal interviews, and their dates:

Birge Clark Commercial Inventory ; P.A. Times 2/7/22, 9/12, 10/15/25, 1/6/26;  
Historical Association files ; Book 548, Deeds, p. 294, 2/7/22 (Santa Clara Co. Recorder);  
Exploring Palo Alto's Past, AAUW; Historic Resources Board, National Register of Historic Places Nomination, 1985

23. Date form prepared: 1978, 1981, 1985 By (name): Lydia Moran; Historic Resources Board; P.A. Hist. Assn.  
 Address: 250 Hamilton Ave City Palo Alto ZIP: 94301  
 Phone: \_\_\_\_\_ Organization: AAUW

(State Use Only)

HISTORIC AMERICA, HABS et al,  
Wash., D.C., 1983, p. 343

HISTORIC RESOURCES INVENTORY

" ADDITION "

State um \_\_\_\_\_  
 Lat \_\_\_\_\_ Lon \_\_\_\_\_ Era \_\_\_\_\_ Sig \_\_\_\_\_  
 Adm \_\_\_\_\_ T2 \_\_\_\_\_ T3 \_\_\_\_\_ Cat \_\_\_\_\_ HABS \_\_\_\_\_ HAER \_\_\_\_\_ Fed \_\_\_\_\_  
 10-574120-4144390

IDENTIFICATION Cat. II

1. Common name: CC APPROVED 3-4-85 (120-26-070)
2. Historic name, if known: Gotham Shop
3. Street or rural address: 528 - 530 Ramona Street (Ramona Street Historic District)  
 City: Palo Alto ZIP: \_\_\_\_\_ County: Santa Clara
4. Present owner, if known: Frank and Eugenie Crist, Tee Address: P.O. Box 90  
 City: Palo Alto, Ca ZIP: 94302 Ownership is: Public  Private
5. Present Use: Stores Original Use: Stores
- Other past uses: \_\_\_\_\_

DESCRIPTION

6. Briefly describe the present physical appearance of the site or structure and describe any major alterations from its original condition:

The structure is a two-story Monterey/Spanish Colonial Revival commercial building with arcaded ground floor and wooden gallery at second floor. Minor alterations in recent years avoid distorting the original design.

7. Locational sketch map (draw and label site and surrounding streets, roads, and prominent landmarks):

NORTH

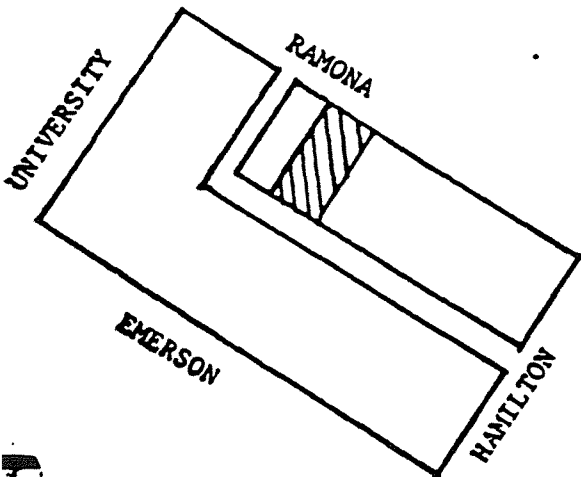

8. Approximate property size:  
 Lot size (in feet) Frontage 46  
 Depth 100  
 or approx. acreage \_\_\_\_\_

9. Condition: (check one)

- a. Excellent  b. Good  c. Fair   
 d. Deteriorated  e. No longer in existence

10. Is the feature a. Altered?  b. Unaltered?

11. Surroundings: (Check more than one if necessary)

- a. Open land  b. Scattered buildings   
 c. Densely built-up  d. Residential   
 e. Commercial  f. Industrial   
 g. Other

12. Threats to site:

- a. None known  b. Private development   
 c. Zoning  d. Public Works project   
 e. Vandalism  f. Other

13. Date(s) of enclosed photograph(s): 11/21/85 1978

14. Primary exterior building material: a. Stone  b. Brick  c. Stucco  d. Adobe  e. Wood   
 f. Other  tile
15. Is the structure: a. On its original site?  b. Moved?  c. Unknown?
16. Year of initial construction 1926 This date is: a. Factual  b. Estimated
17. Architect (if known): Birge Clark
18. Builder (if known): Wells Goodenough, builder
19. Related features: a. Barn  b. Carriage house  c. Outhouse  d. Shed(s)  e. Formal garden(s)   
 f. Windmill  g. Watertower/tankhouse  h. Other  i. None

**SIGNIFICANCE**

20. Briefly state historical and/or architectural importance (include dates, events, and persons associated with the site when known):

Of lesser design quality than others in its group, but as part of the street face, this building is a very important structure in an urban design sense. It was built for Philip M. Lansdale and Edward C. Thoits, and owners and designers intended it to harmonize with the other structures then being placed on Ramona Street in the 500 block.

21. Main theme of the historic resource: (Check only one): a. Architecture  b. Arts & Leisure   
 c. Economic/Industrial  d. Exploration/Settlement  e. Government  f. Military   
 g. Religion  h. Social/Education

22. Sources: List books, documents, surveys, personal interviews, and their dates: Historic Resources Board, National Register of Historic Places Nomination, 1985  
Birge Clark Commercial Inventory

Revised 1981 - Birge Clark - member Historic Resources Board

23. Date form prepared: 1978 By (name): Lydia Moran  
 Address: 1037 Greenwood City: Palo Alto ZIP: 94301  
 Phone: 321-8858 Organization: AAUW

(State Use Only)



HISTORIC RESOURCES INVENTORY

"ADDITION"

IDENTIFICATION Cat. II (CC APPROVED 3-4-85)

(State use)  
 Form \_\_\_\_\_ O \_\_\_\_\_ NR \_\_\_\_\_ SHI \_\_\_\_\_  
 Lat \_\_\_\_\_ Lon \_\_\_\_\_ Era \_\_\_\_\_ Sig \_\_\_\_\_  
 Adm \_\_\_\_\_ T2 \_\_\_\_\_ T3 \_\_\_\_\_ Cat \_\_\_\_\_ HABS \_\_\_\_\_ HAER \_\_\_\_\_ Fed \_\_\_\_\_

1. Common name: Rita on Ramona, Travel Office, Melody Lane (120-26-071)
2. Historic name, if known: \_\_\_\_\_
3. Street or rural address: 532 - 534 - 536 Ramona Street (Ramona Street Historic District)  
 City: Palo Alto ZIP: \_\_\_\_\_ County: Santa Clara
4. Present owner, if known: Norman & Jennie Helwig Address: 200 Lyell Street  
 City: Los Altos ZIP: 94022 Ownership is: Public  Private
5. Present Use: Business District Original Use: stores
- Other past uses: \_\_\_\_\_

DESCRIPTION

6. Briefly describe the present physical appearance of the site or structure and describe any major alterations from its original condition:

A one- and two-story Spanish Colonial Revival office/commercial building with an arcaded ground floor, this structure also has decorative iron balconies on the second floor.

Except for signs, no change from original.

7. Locational sketch map (draw and label site and surrounding streets, roads, and prominent landmarks):

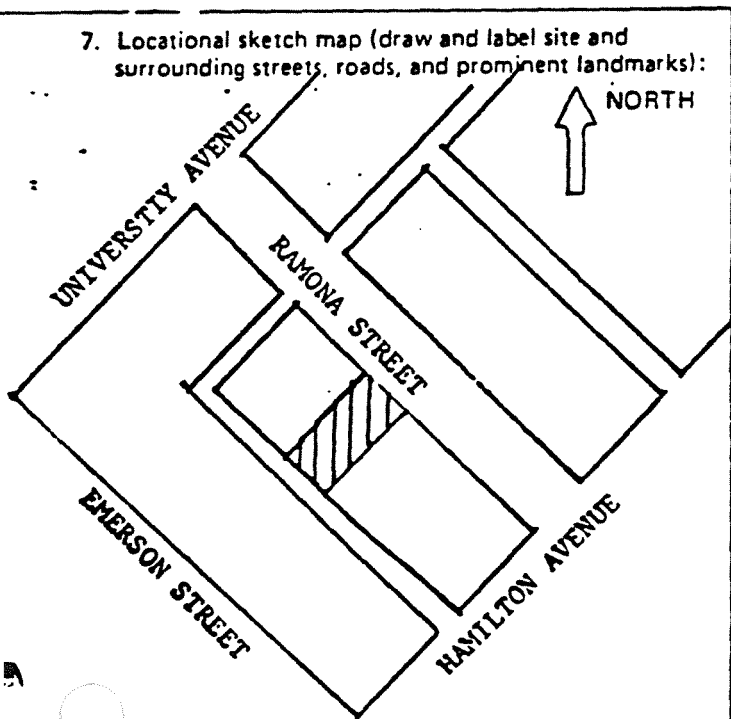

8. Approximate property size:

Lot size (in feet) Frontage 46  
 Depth 100  
 or approx. acreage \_\_\_\_\_

9. Condition: (check one)

- a. Excellent  b. Good  c. Fair   
 d. Deteriorated  e. No longer in existence

10. Is the feature a. Altered?  b. Unaltered?

11. Surroundings: (Check more than one if necessary)

- a. Open land  b. Scattered buildings   
 c. Densely built-up  d. Residential   
 e. Commercial  f. Industrial   
 g. Other

12. Threats to site:

- a. None known  b. Private development   
 c. Zoning  d. Public Works project   
 e. Vandalism  f. Other

13. Date(s) of enclosed photograph(s): 1978

14. Primary exterior building material: a. Stone  b. Brick  c. Stucco  d. Adobe  e. Wood   
 f. Other
15. Is the structure: a. On its original site?  b. Moved?  c. Unknown?
16. Year of initial construction 1926 This date is: a. Factual  b. Estimated
17. Architect (if known): Birge Clark
18. Builder (if known): Wells Goodenough, builder
19. Related features: a. Barn  b. Carriage house  c. Outhouse  d. Shed(s)  e. Formal garden(s)   
 f. Windmill  g. Watertower/tankhouse  h. Other  i. None

**SIGNIFICANCE**

20. Briefly state historical and/or architectural importance (include dates, events, and persons associated with the site when known):

The structure is a good but not spectacular design which becomes important through its contributions to the streetscape.

Part of group of stores built by Palo Alto Improvement Co. to further establish unique character of Ramona Street.

21. Main theme of the historic resource: (Check only one): a. Architecture  b. Arts & Leisure   
 c. Economic/Industrial  d. Exploration/Settlement  e. Government  f. Military   
 g. Religion  h. Social/Education

22. Sources: List books, documents, surveys, personal interviews, and their dates: Historic Resources Board, National Register of Historic Places Nomination, 1985  
Birge Clark Commercial Inventory  
Revised 1981 - Birge Clark, member Historic Resources Board

23. Date form prepared: 1978 By (name): Lydia Moran  
 Address: 1037 Greenwood City: Palo Alto ZIP: 94301  
 Phone: \_\_\_\_\_ Organization: \_\_\_\_\_

(State Use Only)

HISTORIC RESOURCES INVENTORY

" ADDITION "

State or

Lat \_\_\_\_\_ Lon \_\_\_\_\_ Era \_\_\_\_\_ Sig \_\_\_\_\_

Adm \_\_\_\_\_ T2 \_\_\_\_\_ T3 \_\_\_\_\_ Cat \_\_\_\_\_ HABS \_\_\_\_\_ HAER \_\_\_\_\_ Fed \_\_\_\_\_

IDENTIFICATION Cat. I

Common name: CC APPROVED 3-4-85

(120-26-067)

2. Historic name, if known: \_\_\_\_\_

3. Street or rural address 533-39 Ramona Street (Ramona Street Historic District)

City: Palo Alto ZIP: \_\_\_\_\_ County: Santa Clara

4. Present owner, if known: De Lemos Properties Address: PO Box 555

City: Palo Alto, Ca ZIP: 94302 Ownership is: Public  Private

5. Present Use: Stores Original Use: Stores

Other past uses: \_\_\_\_\_

DESCRIPTION

6. Briefly describe the present physical appearance of the site or structure and describe any major alterations from its original condition:

This two-story Spanish Colonial Revival commercial office building features a recessed arched entrance and large centrally-placed balcony. The structure surrounds a patio and is enriched inside and out with tiles, decorative paving patterns, and very fine iron work.

7. Locational sketch map (draw and label site and surrounding streets, roads, and prominent landmarks):

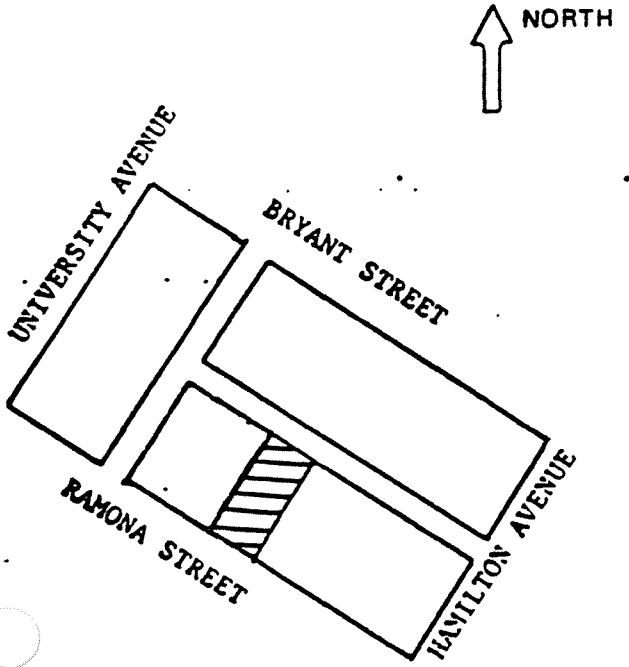

8. Approximate property size:  
Lot size (in feet) Frontage 80  
Depth 100  
or approx. acreage \_\_\_\_\_

9. Condition: (check one)  
a. Excellent  b. Good  c. Fair   
d. Deteriorated  e. No longer in existence

10. Is the feature a. Altered?  b. Unaltered?

11. Surroundings: (Check more than one if necessary)  
a. Open land  b. Scattered buildings   
c. Densely built-up  d. Residential   
e. Commercial  f. Industrial   
g. Other

12. Threats to site:  
a. None known  b. Private development   
c. Zoning  d. Public Works project   
e. Vandalism  f. Other

13. Date(s) of enclosed photograph(s): 1978

11/21/85

NOTE: The following (Items 14-19) are for structures only.

14. Primary exterior building material: a. Stone  b. Brick  c. Stucco  d. Adobe  e. Wood   
f. Other  \_\_\_\_\_
15. Is the structure: a. On its original site?  b. Moved?  c. Unknown?
16. Year of initial construction 1938 This date is: a. Factual  b. Estimated
17. Architect (if known): Pedro Lemos
18. Builder (if known): Pedro Lemos
19. Related features: a. Barn  b. Carriage house  c. Outhouse  d. Shed(s)  e. Formal garden(s)   
f. Windmill  g. Watertower/tankhouse  h. Other  \_\_\_\_\_ None

SIGNIFICANCE

20. Briefly state historical and/or architectural importance (include dates, events, and persons associated with the site when known):

The structure is a superb, inventive office/commercial complex by a local master which is also a major contributor to an important streetscape.

"The same care and delight (Lemos) took in handcrafted details is evident here as in his earlier building across the street. Pebbles are embedded in concrete in a decorative manner and colorful handmade tiles adorn the risers of the steps. Embellishment of even the drinking fountain and rear mailboxes is not overlooked."

Exploring Palo Alto's Past, AAUW 1977

21. Main theme of the historic resource: (Check only one): a. Architecture  b. Arts & Leisure   
c. Economic/Industrial  d. Exploration/Settlement  e. Government  f. Military   
g. Religion  h. Social/Education
22. Sources: List books, documents, surveys, personal interviews, and their dates:  
P.A. Times 10/29/27, 3/18/38  
Ramona Street Historic District file, Hist. Resources Bd.  
A.A.U.W., Exploring Palo Alto's Past, 1977
23. Date form prepared: 1978 By (name): City of Palo Alto (Revised 1981, Historic Resources Board)  
Address: 250 Hamilton Ave City Palo Alto, Ca 94301 ZIP: \_\_\_\_\_  
Phone: \_\_\_\_\_ Organization: \_\_\_\_\_

(State Use Only)

NR-3

HISTORIC RESOURCES INVENTORY

"ADDITION"

State use

Lat \_\_\_\_\_ Lon \_\_\_\_\_ Era \_\_\_\_\_ Sig \_\_\_\_\_  
Adm \_\_\_\_\_ T2 \_\_\_\_\_ T3 \_\_\_\_\_ Cat \_\_\_\_\_ MABS \_\_\_\_\_ HAER \_\_\_\_\_ Fed \_\_\_\_\_

IDENTIFICATION Cat. II

(CC APPROVED 3-4-85)

(120-26-072)

1. Common name: \_\_\_\_\_
2. Historic name, if known: \_\_\_\_\_
3. Street or rural address: 538-540-542 Ramona Street (Ramona Street Historic District)  
City: Palo Alto ZIP: \_\_\_\_\_ County: Santa Clara
4. Present owner, if known: Darrell E and Angelin M Dukes Address: 1156 N. 4th St  
City: San Jose, Ca ZIP: 95112 Ownership is: Public  Private
5. Present Use: Stores Original Use: Stores
- Other past uses: \_\_\_\_\_

DESCRIPTION

6. Briefly describe the present physical appearance of the site or structure and describe any major alterations from its original condition:

The structure is a one and two story, Spanish Colonial Revival galleried commercial/office building. The relationship between the shopfronts and sidewalks is particularly fine.

7. Locational sketch map (draw and label site and surrounding streets, roads, and prominent landmarks):

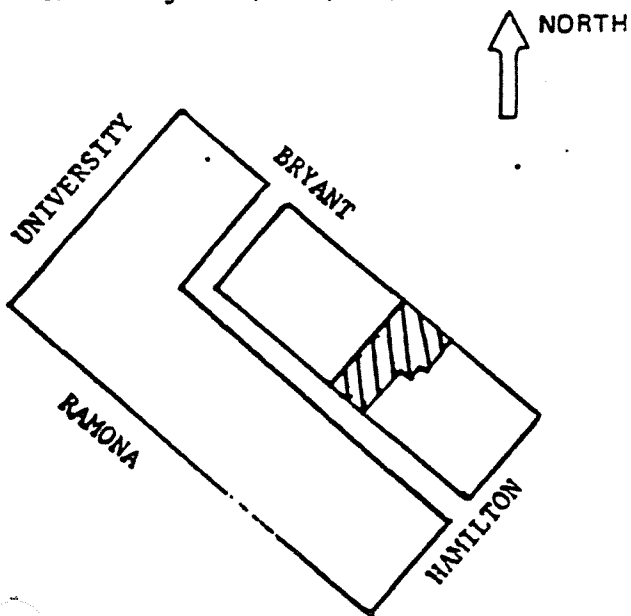

11/21/85

8. Approximate property size:

Lot size (in feet) Frontage 46  
Depth 100  
or approx. acreage \_\_\_\_\_

9. Condition: (check one)

- a. Excellent  b. Good  c. Fair   
d. Deteriorated  e. No longer in existence

10. Is the feature a. Altered?  b. Unaltered?

11. Surroundings: (Check more than one if necessary)

- a. Open land  b. Scattered buildings   
c. Densely built-up  d. Residential   
e. Commercial  f. Industrial   
g. Other

12. Threats to site:

- a. None known  b. Private development   
c. Zoning  d. Public Works project   
e. Vandalism  f. Other

13. Date(s) of enclosed photograph(s): 1978



NOTE: The following (Items 14-19) are for structures only.

14. Primary exterior building material: a. Stone  b. Brick  c. Stucco  d. Adobe  e. Wood   
 f. Other
15. Is the structure: a. On its original site?  b. Moved?  c. Unknown?
16. Year of initial construction 1927 This date is: a. Factual  b. Estimated
17. Architect (if known): Birge Clark
18. Builder (if known): Wells Goodenough
19. Related features: a. Barn  b. Carriage house  c. Outhouse  d. Shed(s)  e. Formal garden(s)   
 f. Windmill  g. Watertower/tankhouse  h. Other  i. None

## SIGNIFICANCE:

20. Briefly state historical and/or architectural importance (include dates, events, and persons associated with the site when known):

A fine building performing an important urban design function.

538 was specially designed for Phelps-Terkel, a quality men's store. The beamed ceiling in the front and the rear room with fireplace remain as originally designed.

21. Main theme of the historic resource: (Check only one): a. Architecture  b. Arts & Leisure   
 c. Economic/Industrial  d. Exploration/Settlement  e. Government  f. Military   
 g. Religion  h. Social/Education

22. Sources: List books, documents, surveys, personal interviews, and their dates:

P.A. Times 3/3/27

Birge Clark Commercial Inventory

Historic Resources Board, National Reg. of Hist. Places Nomination, 1985

Revised 1981 - Birge Clark - member Historic Resources Board

23. Date form prepared: 1978 By (name): Janet London  
 Address: Barnes 8-C City: Stanford ZIP: 94305  
 Phone: \_\_\_\_\_ Organization: \_\_\_\_\_

(State Use Only)

HISTORIC RESOURCES INVENTORY

"ADDITION"

State of \_\_\_\_\_  
 Lat \_\_\_\_\_ Lon \_\_\_\_\_ Era \_\_\_\_\_ Sig \_\_\_\_\_  
 Adm \_\_\_\_\_ T2 \_\_\_\_\_ T3 \_\_\_\_\_ Cat \_\_\_\_\_ HABS \_\_\_\_\_ HAER \_\_\_\_\_ Fed \_\_\_\_\_

IDENTIFICATION Cat. IV (CC APPROVED 3-4-85)

1. Common name: Ramona's Restaurant, Wooster Optical  
 2. Historic name, if known: Homeware Store (120-26-066)  
 3. Street or rural address: 541-545 Ramona Street (Ramona Street Historic District)  
 City: Palo Alto ZIP: \_\_\_\_\_ County: Santa Clara  
 4. Present owner, if known: Alhouse Realty Co. Address: 2450 El Camino  
 City: Palo Alto ZIP: 94306 Ownership is: Public  Private   
 5. Present Use: Stores Original Use: Stores  
 Other past uses: \_\_\_\_\_

DESCRIPTION

6. Briefly describe the present physical appearance of the site or structure and describe any major alterations from its original condition:

This 2-story building performs a quiet support function in a remarkable block here.

7. Locational sketch map (draw and label site and surrounding streets, roads, and prominent landmarks):

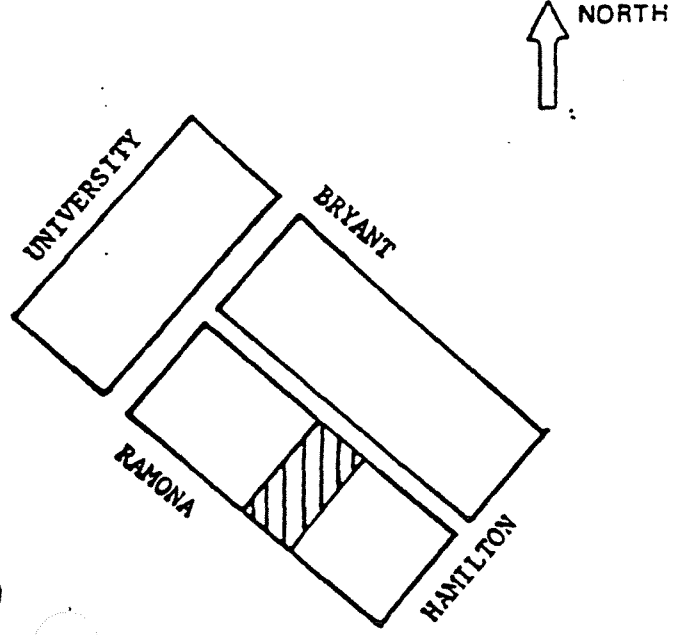

11/21/85

8. Approximate property size:  
 Lot size (in feet) Frontage 50  
 Depth 100 ;  
 or approx. acreage \_\_\_\_\_

9. Condition: (check one)  
 a. Excellent  b. Good  c. Fair   
 d. Deteriorated  e. No longer in existence   
 10. Is the feature a. Altered?  b. Unaltered?   
 11. Surroundings: (Check more than one if necessary)  
 a. Open land  b. Scattered buildings   
 c. Densely built-up  d. Residential   
 e. Commercial  f. Industrial   
 g. Other  \_\_\_\_\_  
 12. Threats to site:  
 a. None known  b. Private development   
 c. Zoning  d. Public Works project   
 e. Vandalism  f. Other  \_\_\_\_\_

13. Date(s) of enclosed photograph(s): 1978

14. Primary exterior building material:  a. Stone  b. Brick  c. Stucco  d. Adobe  e. wood   
 f. Other
15. Is the structure: a. On its original site?  b. Moved?  c. Unknown?
16. Year of initial construction: 1928 This date is: a. Factual  b. Estimated
17. Architect (if known): Birge Clark
18. Builder (if known): Wells Goodenough
19. Related features: a. Barn  b. Carriage house  c. Outhouse  d. Shed(s)  e. Formal garden(s)   
 f. Windmill  g. Watertower/tankhouse  h. Other  i. None

**SIGNIFICANCE**

20. Briefly state historical and/or architectural importance (include dates, events, and persons associated with the site when known):

This building is really part of the 4-story medical/dental building whose parking garage extends underneath it. Although built simultaneously, both tenants were intimately involved in design. 541 - The "Homeware Store", was operated for several years by Mr. and Mrs. Crandall. 545 was designed as the Home Foundation Savings and Loan. 541 Homeware Store and Gotham Shop, on the opposite side of the street, were the principal retail attractions for 10 years. Note that these two buildings and the 4-story professional building on the corner were carefully designed to accentuate different occupancies. The current fronts are marred by large signs. It is interesting to note that originally the leases prohibited any signs other than surface lettering or small 2' x 2' hanging shield-type signs.

21. Main theme of the historic resource: (Check only one): a. Architecture  b. Arts & Leisure   
 c. Economic/Industrial  d. Exploration/Settlement  e. Government  f. Military   
 g. Religion  h. Social/Education

22. Sources: List books, documents, surveys, personal interviews, and their dates:  
P.A. Times 12/22/27 ; Historic Resources Board, National Register of Historic Places Nomination, 1985  
Revised 1981 - Birge Clark - member Historic Resources Board

23. Date form prepared: 1978 By (name): City of Palo Alto  
 Address: 250 Hamilton Ave City Palo Alto, Ca 94301 ZIP: \_\_\_\_\_  
 Phone: \_\_\_\_\_ Organization: \_\_\_\_\_

(State Use Only)



HISTORIC RESOURCES INVENTORY

State of CA UTM \_\_\_\_\_ N \_\_\_\_\_ NR \_\_\_\_\_ SML \_\_\_\_\_  
 Lat \_\_\_\_\_ Lon \_\_\_\_\_ Era \_\_\_\_\_ Sig \_\_\_\_\_  
 Adm : 2 T3 Cor: MABS MAER Fed \_\_\_\_\_

IDENTIFICATION Cat. ~~III~~ CAT. II (CC Approved 5/6/88)

1. Common name: \_\_\_\_\_
2. Historic name, if known: \_\_\_\_\_
3. Street or rural address: 628 Ramona Street  
 City: Palo Alto ZIP: \_\_\_\_\_ County: Santa Clara
4. Present owner, if known: Los Altos Rancho Market Address: 510 Bay Road  
 City: Menlo Park ZIP: 94025 Ownership is: Public  Private
5. Present Use: Commercial Original Use: Commercial  
 Other past uses: \_\_\_\_\_

DESCRIPTION

The facade of this Spanish Colonial Revival, stucco faced building has a simple ground floor storefront shaded by an overhang of exposed beam ends, paired arched windows on the second floor and a red tile cap at the roofline. This commercial structure is a companion building to the larger adjacent building, 630 Ramona, which was built at the same time. The front of 628 is purposely set back from 630, creating the sense of two buildings along the street and emphasizing the prominence of 630 and establishing the proportions of each building.

7. Locational sketch map (draw and label site and surrounding streets, roads, and prominent landmarks):

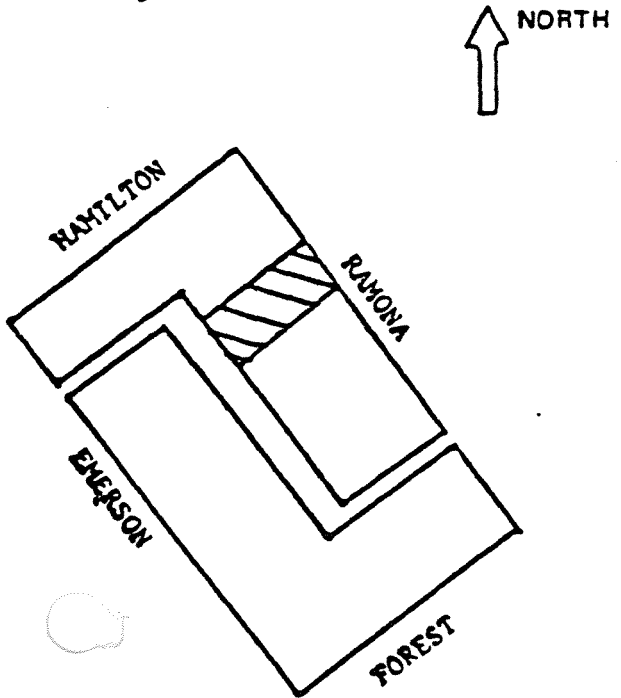

JAN 21 1988

8. Approximate property size:  
 Lot size (in feet) Frontage 50  
 Depth 102.50  
 or approx. acreage \_\_\_\_\_
9. Condition: (check one)  
 a. Excellent  b. Good  c. Fair   
 d. Deteriorated  e. No longer in existence
10. Is the feature a. Altered?  b. Unaltered?
11. Surroundings: (Check more than one if necessary)  
 a. Open land  b. Scattered buildings   
 c. Densely built-up  d. Residential   
 e. Commercial  f. Industrial   
 g. Other  \_\_\_\_\_
12. Threats to site:  
 a. None known  b. Private development   
 c. Zoning  d. Public Works project   
 e. Vandalism  f. Other  \_\_\_\_\_
13. Date(s) of enclosed photograph(s): 1978

NOTE: The following (Items 14-19) are for structures only.

14. Primary exterior building material: a. Stone  b. Brick  c. Stucco  d. Adobe  e. Wood   
f. Other
15. Is the structure: a. On its original site?  b. Moved?  c. Unknown?
16. Year of initial construction 1927 This date is: a. Factual  b. Estimated
17. Architect (if known): Birge Clark
18. Builder (if known): Minton Company
19. Related features: a. Barn  b. Carriage house  c. Outhouse  d. Shed(s)  e. Formal garden(s)   
f. Windmill  g. Watertower/tankhouse  h. Other  i. None

SIGNIFICANCE

20. Briefly state historical and/or architectural importance (include dates, events, and persons associated with the site when known):

Although an interesting building in its own right, 628 Ramona is especially unique and important as an adjunct to its companion building, 630 Ramona since it was deliberately designed to create and emphasize the the proportions of each structure and lend coordinated variation and interest along the street. The building is a fine, classic example of a small commercial storefront building of its period. It is an important and integral part of the collection of historic buildings within the block.

21. Main theme of the historic resource: (Check only one): a. Architecture  b. Arts & Leisure   
c. Economic/Industrial  d. Exploration/Settlement  e. Government  f. Military   
g. Religion  h. Social/Education

22. Sources: List books, documents, surveys, personal interviews, and their dates:

F.A. Times 8/3, 10/12/27; 2/25/28

Birge Clark

Revised 1981 - Birge Clark, member Historic Resources Board

23. Date form prepared: 1978 By (name): City of Palo Alto  
Address: 250 Hamilton Ave City Palo Alto, Ca 94301 ZIP: \_\_\_\_\_  
Phone: \_\_\_\_\_ Organization: \_\_\_\_\_

NR-4

(State Use Only)

JAN 21 1988

HISTORIC RESOURCES INVENTORY

State or other \_\_\_\_\_  
 UTM \_\_\_\_\_ O \_\_\_\_\_ N11 \_\_\_\_\_ SMI \_\_\_\_\_  
 Lat \_\_\_\_\_ Lon \_\_\_\_\_ Era \_\_\_\_\_ Sp \_\_\_\_\_  
 Adm \_\_\_\_\_ T2 \_\_\_\_\_ T3 \_\_\_\_\_ Cal \_\_\_\_\_ MABS \_\_\_\_\_ MAER \_\_\_\_\_ Fed \_\_\_\_\_

CLASSIFICATION ~~III~~ ~~II~~ CAT. II (UC approved 5/16/88)

1. Common name: The London House
  2. Historic name, if known: Stanford Upholstering; Adolf Richter, owner
  3. Street or rural address: 630 Ramona Street  
 City: Palo Alto ZIP: \_\_\_\_\_ County: Santa Clara
  4. Present owner, if known: Douglas and Sheila Barnes Address: 1588 Castilleja Avenue  
 City: Palo Alto ZIP: \_\_\_\_\_ Ownership is: Public  Private
  5. Present Use: Commercial Original Use: Commercial
- Other past uses: \_\_\_\_\_

DESCRIPTION

6. Briefly describe the present physical appearance of the site or structure and describe any major alterations from its original condition:

This two-story Spanish Colonial Revival commercial building features a first floor recessed arcade with beamed ceiling that is formed by three semi circular arched bays in the facade. At the second level three sets of french doors are centered over the bays, each opening onto cantilevered balconies with wrought iron railings. The distinctive interior features a two-story space formed by an encircling balcony.  
 (See also 628 Ramona, the companion building.)

7. Locational sketch map (draw and label site and surrounding streets, roads, and prominent landmarks):

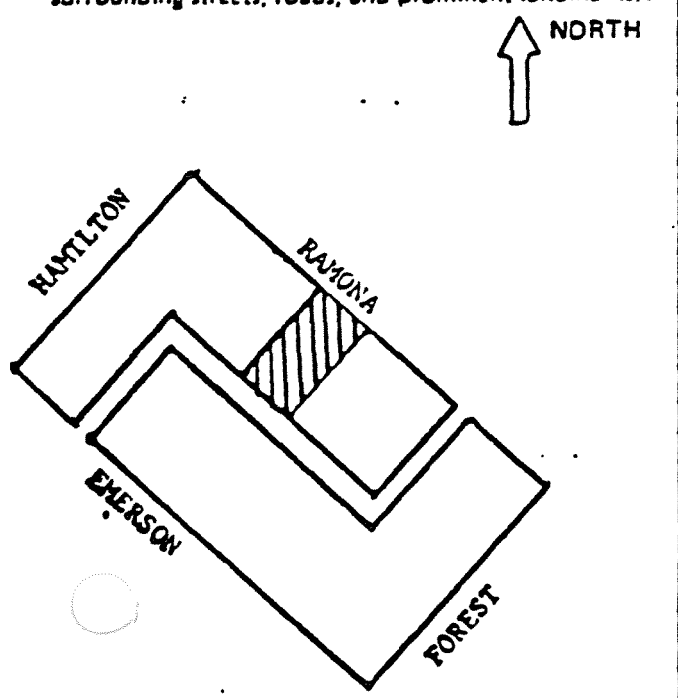

- B. Approximate property size:  
 Lot size (in feet) Frontage 50  
 Depth 102.50  
 or approx. acreage \_\_\_\_\_
8. Condition: (check one)  
 a. Excellent  b. Good  c. Fair   
 d. Deteriorated  e. No longer in existence
10. Is the feature a. Altered?  b. Unaltered?
11. Surroundings: (Check more than one if necessary)  
 a. Open land  b. Scattered buildings   
 c. Densely built-up  d. Residential   
 e. Commercial  f. Industrial   
 g. Other  \_\_\_\_\_
12. Threats to site:  
 a. None known  b. Private development   
 c. Zoning  d. Public Works project   
 e. Vandalism  f. Other  \_\_\_\_\_
13. Date(s) of enclosed photograph(s): 1978

17. Architect (if known): Birge Clark

18. Builder (if known): Minton Company

19. Related features: a. Barn  b. Carriage house  c. Outhouse  d. Shed(s)  e. Formal garden(s)   
f. Windmill  g. Watertower/tankhouse  h. Other  i. None

**SIGNIFICANCE**

20. Briefly state historical and/or architectural importance (include dates, events, and persons associated with the site when known):

The structure is an important contribution to the Spanish Colonial Revival ambience of Downtown Palo Alto. The building was built for Adolf Richter, who occupied the major portion. A rental space was provided on the west side with a different architectural appearance. Richter, a native of Germany, came to Palo Alto in 1913 and established a long-lasting furniture upholstery business.

An outstanding building in its own right, 630 Ramona is especially unique in its relationship to the companion building, 628 Ramona. Designed and built together, 630 was deliberately designed as the prominent storefront.

\*The architect refers to this style as California Colonial

21. Main theme of the historic resource: (Check only one): a. Architecture  b. Arts & Leisure   
c. Economic/Industrial  d. Exploration/Settlement  e. Government  f. Military   
g. Religion  h. Social/Education

22. Sources: List books, documents, surveys, personal interviews, and their dates: P.A. Times 8/3, 10/12/27; 2/25/28.  
Birge Clark Commercial Inventory 5/9/47

Revised 1981 - Birge Clark - member Historic Resources Board

23. Date form prepared: May 1978 By (name): Lydia Moran  
Address: 1037 Greenwood City: Palo Alto ZIP: 94301  
Phone: 321-8858 Organization: -AAUW

(State Use Only)

NR-4

JAN 21 1988

HISTORIC RESOURCES INVENTORY

State use only  
 Ser \_\_\_\_\_ Sta \_\_\_\_\_ Mo. \_\_\_\_\_ Yr. \_\_\_\_\_  
 UTM \_\_\_\_\_ O \_\_\_\_\_ NR \_\_\_\_\_ SHL \_\_\_\_\_  
 Lat \_\_\_\_\_ Lon \_\_\_\_\_ Era \_\_\_\_\_ Sq \_\_\_\_\_  
 Adm T2 \_\_\_\_\_ T3 \_\_\_\_\_ Cat MABS \_\_\_\_\_ MAER \_\_\_\_\_ Fed \_\_\_\_\_

IDENTIFICATION Cat. II (Approved 5/6/88)

1. Common name: Palo Alto Art Club
2. Historic name, if known: Winsor's Cabinet Shop
3. Street or rural address: 668 Ramona Street (CR: 225-227 Forest)  
 City: Palo Alto ZIP: \_\_\_\_\_ County: Santa Clara
4. Present owner, if known: Palo Alto Art Club Address: Same  
 City: \_\_\_\_\_ ZIP: \_\_\_\_\_ Ownership is: Public  Private
5. Present Use: Art Club Original Use: \_\_\_\_\_  
 Other past uses: \_\_\_\_\_

DESCRIPTION

6. Briefly describe the present physical appearance of the site or structure and describe any major alterations from its original condition. This stucco clad commercial structure is composed of two pitched roof elements separated by a three story, flat roofed tower element. The ground floor storefronts consist of large divided display windows in each of the end elements, and a central second floor entrance and enclosed staircase. A set of small windows follows the angle of the stairs to the second floor. The design skillfully combines Spanish Colonial Revival, Mission Revival, and Craftsman style features. The varied fenestration, the elegant wrought iron corner balconies capped with red tile overhangs, and the three element form with central tower combine to create a building of presence and strong visual interest.

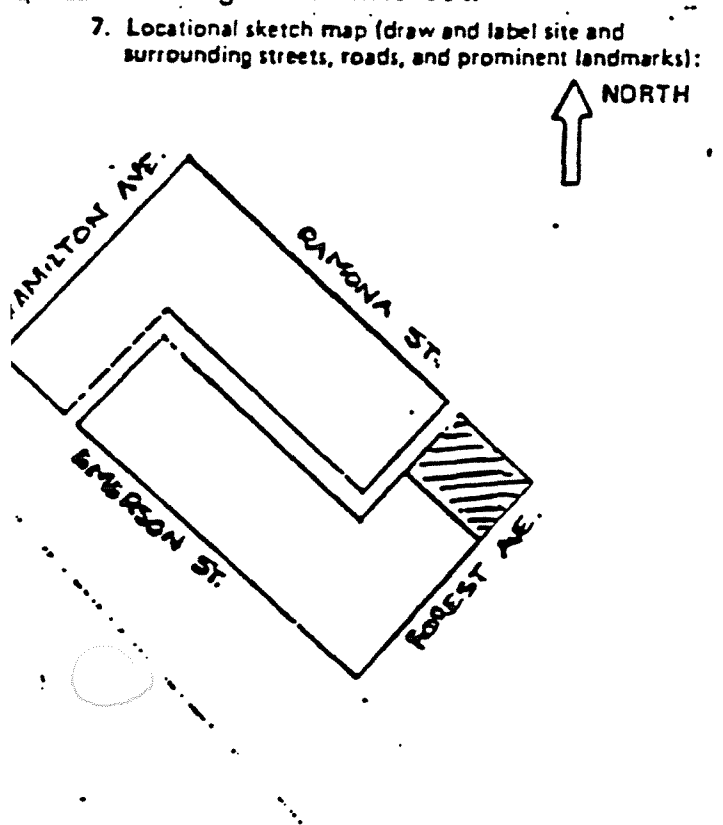

8. Approximate property size:  
 Lot size (in feet) Frontage 85  
 Depth 66  
 or approx. acreage \_\_\_\_\_
9. Condition: (check one)  
 a. Excellent  b. Good  c. Fair   
 d. Deteriorated  e. No longer in existence
10. Is the feature a. Altered?  b. Unaltered?
11. Surroundings: (Check more than one if necessary)  
 a. Open land  b. Scattered buildings   
 c. Densely built-up  d. Residential   
 e. Commercial  f. Industrial   
 g. Other
12. Threats to site:  
 a. None known  b. Private development   
 c. Zoning  d. Public Works project   
 e. Vandalism  f. Other
13. Date(s) of enclosed photograph(s): \_\_\_\_\_ 1978



NOTE: The following (Items 14-19) are structures only.

14. Primary exterior building material: a. Stone  b. Brick  c. Stucco  d. Adobe  e. Wood   
f. Other
15. Is the structure: a. On its original site?  b. Moved?  c. Unknown?
16. Year of initial construction 1926 This date is: a. Factual  b. Estimated
17. Architect (if known): Birge Clark
18. Builder (if known): Wells P. Goodenough
19. Related features: a. Barn  b. Carriage house  c. Outhouse  d. Shed(s)  e. Formal garden(s)   
f. Windmill  g. Watertower/tankhouse  h. Other  i. None

GNIFICANCE

20. Briefly state historical and/or architectural importance (include dates, events, and persons associated with the site when known):

The first building on this site was a two-story, Mission Revival style residence designed by R.H. Walker and built by L.S. Bean for Bernard Distal. Distal was a native of France who settled in Mayfield about 1864 with his brother Leonard, and was the earliest viticulturist and wine maker in the locality. He moved to Palo Alto in 1904. In 1915 the site was purchased by Henry R. Winsor. Winsor, a native of London, came to the city in 1906 from Tasmania. He was a cabinet maker first working for the Dudfield Lumber Co. and then independently. His son Alvin followed him in the wood-working crafts (as does a grandson), and the Winsor name was locally preeminent in fine furniture and cabinet construction and restoration. Three years after his new shop and sales buildings were completed, they were seriously damaged by fire, but soon restored. The Palo Alto Art Club occupied the building in 1967, although for several years afterward the Winsor shop continued in adjacent space on Forest Avenue.

This building creates a strong presence that anchors the end of this commercial block and turns the corner gracefully. Along with the two-building complex at 628-632 Ramona, this structure forms the dominant historic character of most of the block.

21. Main theme of the historic resource: (Check only one): a. Architecture  b. Arts & Leisure   
c. Economic/Industrial  d. Exploration/Settlement  e. Government  f. Military   
g. Religion  h. Social/Education

22. Sources: List books, documents, surveys, personal interviews, and their dates: P.A. City Directories; P.A. Times, 7/15, 12/30/04; 6/10, 7/26, 8/28, 10/11/26; 10/30/29; 5/19/33; 3/15/37; 5/21/46; 9/26/69; 1/11/75; H.S. Foote, ed. Pen-Pictures from the Garden of the World or Santa Clara County, California (Chicago, Lewis Publ. Co., 1888), p. 347.

23. Date form prepared: 1978, 1985 By (name): Historic Resources Board; P.A. Hist. Assn.

Address: 250 Hamilton Ave City Palo Alto, Ca 94301 ZIP: \_\_\_\_\_  
Phone: \_\_\_\_\_ Organization: \_\_\_\_\_

(State Use Only)

JAN 21 1988

HISTORIC RESOURCES INVENTORY

(State use only)  
 Ser \_\_\_\_\_ Site \_\_\_\_\_ Mo. \_\_\_\_\_ Yr. \_\_\_\_\_  
 UTM \_\_\_\_\_ Q \_\_\_\_\_ NR \_\_\_\_\_ SHL \_\_\_\_\_  
 Lat \_\_\_\_\_ Lon \_\_\_\_\_ Era \_\_\_\_\_ Sig \_\_\_\_\_  
 Adm \_\_\_\_\_ T2 \_\_\_\_\_ T3 \_\_\_\_\_ Cat \_\_\_\_\_ HABS \_\_\_\_\_ HAER \_\_\_\_\_ Fed \_\_\_\_\_

IDENTIFICATION Cat. IV

- Common name: \_\_\_\_\_
- Historic name, if known: \_\_\_\_\_
- Street or rural address: 734 Ramona Street-735 Emerson Street  
 City: Palo Alto ZIP: \_\_\_\_\_ County: Santa Clara
- Present owner, if known: Thomas Harrington Address: 105 Fremont Avenue  
 City: Los Altos, Ca 94022 ZIP: \_\_\_\_\_ Ownership is: Public  Private
- Present Use: Graphics and printing Original Use: Auto repair shops  
 Other past uses: Bowling Alley--735 Emerson Street

DESCRIPTION

- Briefly describe the present physical appearance of the site or structure and describe any major alterations from its original condition:

This commercial building, which runs through from Ramona to Emerson Streets, displays restrained features of Classical Revival decorative detail, most visibly remaining on the Ramona Street facade; only traces remain on the Emerson Street frontage, which has been remodeled in recent times.

- Locational sketch map (draw and label site and surrounding streets, roads, and prominent landmarks):

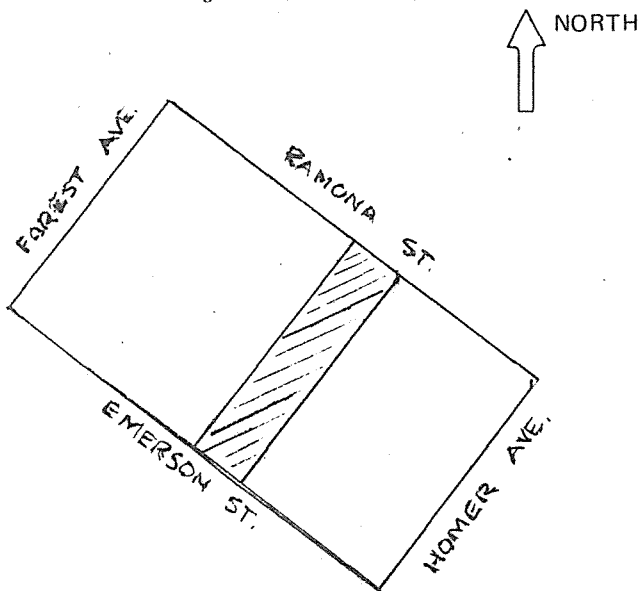

- Approximate property size:  
 Lot size (in feet) Frontage 50  
 Depth 225  
 or approx. acreage \_\_\_\_\_
- Condition: (check one)  
 a. Excellent  b. Good  c. Fair   
 d. Deteriorated  e. No longer in existence
- Is the feature a. Altered?  b. Unaltered?
- Surroundings: (Check more than one if necessary)  
 a. Open land  b. Scattered buildings   
 c. Densely built-up  d. Residential   
 e. Commercial  f. Industrial   
 g. Other
- Threats to site:  
 a. None known  b. Private development   
 c. Zoning  d. Public Works project   
 e. Vandalism  f. Other

- Date(s) of enclosed photograph(s): 1978 (Ramona St.)

NOTE: The following (Items 14-19) are for structures only.

14. Primary exterior building material: a. Stone  b. Brick  c. Stucco  d. Adobe  e. Wood   
f. Other
15. Is the structure: a. On its original site?  b. Moved?  c. Unknown?
16. Year of initial construction 1926 This date is: a. Factual  b. Estimated
17. Architect (if known): Original: Ralph Follmer\*; remodeling 1940, Howell Engineering Co.
18. Builder (if known): Original: Ralph Follmer; remodeling for bowling alley, Howell Engr. Co.
19. Related features: a. Barn  b. Carriage house  c. Outhouse  d. Shed(s)  e. Formal garden(s)   
f. Windmill  g. Watertower/tankhouse  h. Other  i. None

## SIGNIFICANCE

20. Briefly state historical and/or architectural importance (include dates, events, and persons associated with the site when known):

An industrial building set off from the average by Classical Revival facade detail. Until the mid-forties, the owners utilized the Emerson Street frontage as the entry for Grant Ritscher auto repair shop; then the repair shop entry was shifted by Warren May to the Ramona Street end. From 1941-1975, the Indian Bowl (bowling alley) was in the building, with entry on Emerson Street. Though not the first it was the most successful and long-lasting bowling alley in Palo Alto, losing ground only in late years to student center alleys at nearby colleges and alleys introduced into the newer outlying commercial tracts. After Indian Bowl closed, Baker Graphics occupied its space and then extended their operations through from Emerson to Ramona.

\*According to his son, Frank, Ralph Follmer had had architectural training, and, unless the client had an architect, designed the buildings he constructed.

21. Main theme of the historic resource: (Check only one): a. Architecture  b. Arts & Leisure   
c. Economic/Industrial  d. Exploration/Settlement  e. Government  f. Military   
g. Religion  h. Social/Education

22. Sources: List books, documents, surveys, personal interviews, and their dates: P.A. City Directories; P.A. Historical Assn. file on bowling alleys; interview 1985, Thomas Harrington P.A. Times 3/24/26, 5/22/40, 8/6/40; P.A. Building Dept. files; interview 1986, Frank Follmer

23. Date form prepared: 1978, 1985 By (name): Historic Resources Board; P.A. Hist. Assn.  
Address: 250 Hamilton Ave City Palo Alto, Ca 94301 ZIP: \_\_\_\_\_  
Phone: \_\_\_\_\_ Organization: \_\_\_\_\_

(State Use Only)

HISTORIC RESOURCES INVENTORY

(State use only)

Ser \_\_\_\_\_ Site \_\_\_\_\_ Mo. \_\_\_\_\_ Yr. \_\_\_\_\_  
 UTM \_\_\_\_\_ Q \_\_\_\_\_ NR \_\_\_\_\_ SHL \_\_\_\_\_  
 Lat \_\_\_\_\_ Lon \_\_\_\_\_ Era \_\_\_\_\_ Sig \_\_\_\_\_  
 Adm \_\_\_\_\_ T2 \_\_\_\_\_ T3 \_\_\_\_\_ Cat \_\_\_\_\_ HABS \_\_\_\_\_ HAER \_\_\_\_\_ Fed \_\_\_\_\_

IDENTIFICATION Cat. III

- Common name: \_\_\_\_\_
- Historic name, if known: \_\_\_\_\_
- Street or rural address 819 Ramona Street  
 City: Palo Alto ZIP: \_\_\_\_\_ County: Santa Clara
- Present owner, if known: Palo Alto Medical Foundation Address: 300 Homer Avenue  
 City: Palo Alto, Ca 94301 ZIP: \_\_\_\_\_ Ownership is: Public  Private
- Present Use: Abandoned Original Use: Church  
 Other past uses: \_\_\_\_\_

DESCRIPTION

- Briefly describe the present physical appearance of the site or structure and describe any major alterations from its original condition:

**This simple church structure is essentially Classical Revival in style, with minimal detailing. It is possible that the original surface was not stucco.**

- Locational sketch map (draw and label site and surrounding streets, roads, and prominent landmarks):

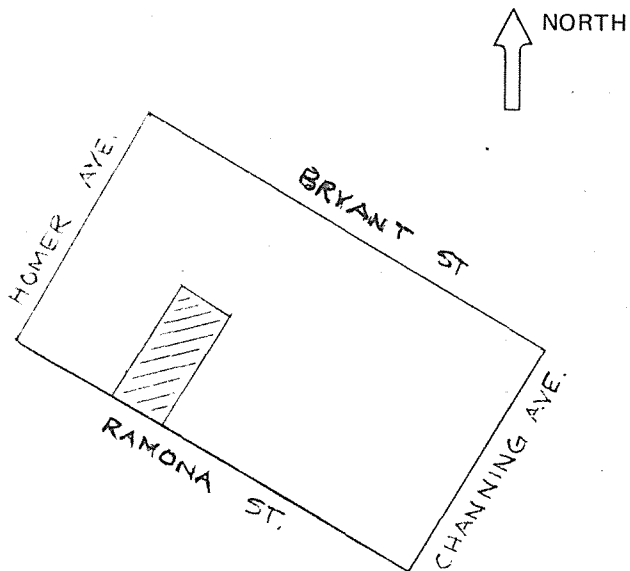

- Approximate property size:  
 Lot size (in feet) Frontage 50  
 Depth 112.5  
 or approx. acreage \_\_\_\_\_
- Condition: (check one)  
 a. Excellent  b. Good  c. Fair   
 d. Deteriorated  e. No longer in existence
- Is the feature a. Altered?  b. Unaltered?
- Surroundings: (Check more than one if necessary)  
 a. Open land  b. Scattered buildings   
 c. Densely built-up  d. Residential   
 e. Commercial  f. Industrial   
 g. Other
- Threats to site:  
 a. None known  b. Private development   
 c. Zoning  d. Public Works project   
 e. Vandalism  f. Other
- Date(s) of enclosed photograph(s): 1978

819 Ramona

NOTE: The following (Items 14-19) are for structures only.

14. Primary exterior building material: a. Stone  b. Brick  c. Stucco  d. Adobe  e. Wood   
f. Other  \_\_\_\_\_
15. Is the structure: a. On its original site?  b. Moved?  c. Unknown?
16. Year of initial construction 1924 This date is: a. Factual  b. Estimated
17. Architect (if known): \_\_\_\_\_
18. Builder (if known): \_\_\_\_\_
19. Related features: a. Barn  b. Carriage house  c. Outhouse  d. Shed(s)  e. Formal garden(s)   
f. Windmill  g. Watertower/tankhouse  h. Other  \_\_\_\_\_ i. None

SIGNIFICANCE

20. Briefly state historical and/or architectural importance (include dates, events, and persons associated with the site when known):  
Formerly the A.M.E. Zion (African Methodist Episcopal) church, which, since 1964, has been located at 3549 Middlefield Road. This was the first black church in Palo Alto, begun in 1919 and holding services at Fraternity Hall. Then, with 22 members and funds raised in part throughout the town, the new building was planned in 1923 and dedicated April 5, 1925. During the Depression, appeals to assist in payment of building and mortgage expenses were generously met by contributions from other churches and from private individuals, Kathleen Norris, Frank Crist, and Fred Tinney, among others.

21. Main theme of the historic resource: (Check only one): a. Architecture  b. Arts & Leisure   
c. Economic/Industrial  d. Exploration/Settlement  e. Government  f. Military   
g. Religion  h. Social/Education
22. Sources: List books, documents, surveys, personal interviews, and their dates: Guy Miller, Palo Alto Community Book; P.A. Times 4/4/25, 4/27/35, 8/2/35, 7/9/71, 12/7/74

23. Date form prepared: 1979, 1985 By (name): Gail Woolley; Historic Resources Board; P.A. Hist. Assn.  
Address: 250 Hamilton Ave City: Palo Alto, Ca 94301 ZIP: \_\_\_\_\_  
Phone: \_\_\_\_\_ Organization: \_\_\_\_\_

(State Use Only)

HISTORIC RESOURCES INVENTORY

(State use only)

Ser \_\_\_\_\_ Site \_\_\_\_\_ Mo. \_\_\_\_\_ Yr. \_\_\_\_\_  
 UTM \_\_\_\_\_ Q \_\_\_\_\_ NR \_\_\_\_\_ SHL \_\_\_\_\_  
 Lat \_\_\_\_\_ Lon \_\_\_\_\_ Era \_\_\_\_\_ Sig \_\_\_\_\_  
 Adm \_\_\_\_\_ T2 \_\_\_\_\_ T3 \_\_\_\_\_ Cat \_\_\_\_\_ HABS \_\_\_\_\_ HAER \_\_\_\_\_ Fed \_\_\_\_\_

IDENTIFICATION Cat. IV

1. Common name: \_\_\_\_\_
2. Historic name, if known: \_\_\_\_\_
3. Street or rural address 935 Ramona Street  
 City: Palo Alto ZIP: \_\_\_\_\_ County: Santa Clara
4. Present owner, if known: Palo Alto Medical Foundation Address: 300 Homer Ave  
 City: Palo Alto, Calif ZIP: 94301 Ownership is: Public  Private
5. Present Use: Residential Original Use: Residential  
 Other past uses: \_\_\_\_\_

DESCRIPTION

6. Briefly describe the present physical appearance of the site or structure and describe any major alterations from its original condition:  
 A standard-format Queen Anne cottage with porch and angled bay, enriched by unusual bracketing and overscaled dormers.

7. Locational sketch map (draw and label site and surrounding streets, roads, and prominent landmarks):

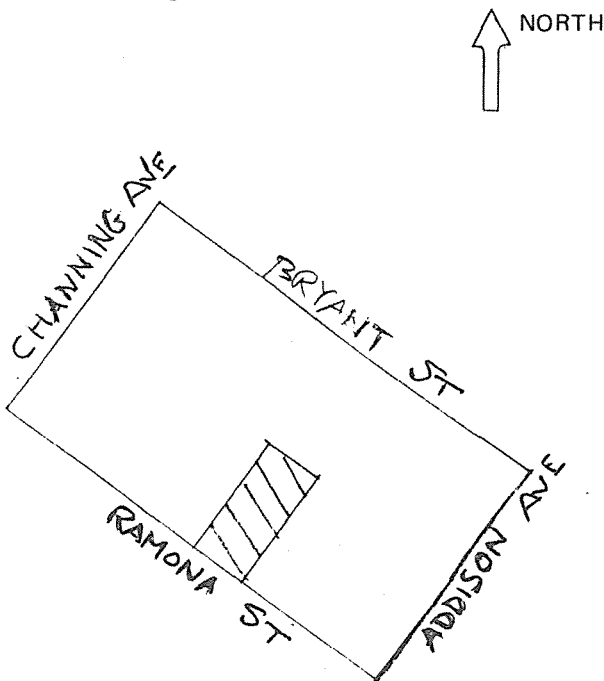

8. Approximate property size:  
 Lot size (in feet) Frontage 50  
 Depth 112.5 ;  
 or approx. acreage \_\_\_\_\_.
9. Condition: (check one)  
 a. Excellent  b. Good  c. Fair   
 d. Deteriorated  e. No longer in existence
10. Is the feature a. Altered?  b. Unaltered?
11. Surroundings: (Check more than one if necessary)  
 a. Open land  b. Scattered buildings   
 c. Densely built-up  d. Residential   
 e. Commercial  f. Industrial   
 g. Other
12. Threats to site:  
 a. None known  b. Private development   
 c. Zoning  d. Public Works project   
 e. Vandalism  f. Other
13. Date(s) of enclosed photograph(s): 1978

NOTE: The following (Items 14-19) are for structures only.

14. Primary exterior building material: a. Stone  b. Brick  c. Stucco  d. Adobe  e. Wood   
 f. Other  \_\_\_\_\_
15. Is the structure: a. On its original site?  b. Moved?  c. Unknown?
16. Year of initial construction 1895 This date is: a. Factual  b. Estimated
17. Architect (if known): \_\_\_\_\_
18. Builder (if known): A.W. Caulkins
19. Related features: a. Barn  b. Carriage house  c. Outhouse  d. Shed(s)  e. Formal garden(s)   
 f. Windmill  g. Watertower/tankhouse  h. Other  \_\_\_\_\_ i. None

## SIGNIFICANCE

20. Briefly state historical and/or architectural importance (include dates, events, and persons associated with the site when known):

The structure is a fine variant of the type, occupied by the builder until 1907 and by Mrs. A. Dimond from 1908-1922. From the mid-twenties onward, the several successive owners shared the space with one or more tenants.

21. Main theme of the historic resource: (Check only one): a. Architecture  b. Arts & Leisure   
 c. Economic/Industrial  d. Exploration/Settlement  e. Government  f. Military   
 g. Religion  h. Social/Education
22. Sources: List books, documents, surveys, personal interviews, and their dates: P.A. City Directories;  
 P.A. Times 9/13/95, 12/3/04

23. Date form prepared: 1978, 1984 By (name): Karmen Newman; Historic Resources Board  
 Address: 250 Hamilton Ave City Palo Alto, Ca 94301 ZIP: \_\_\_\_\_  
 Phone: \_\_\_\_\_ Organization: \_\_\_\_\_

(State Use Only)

**HISTORIC RESOURCES INVENTORY**

(State use only)

Ser \_\_\_\_\_ Site \_\_\_\_\_ Mo. \_\_\_\_\_ Yr. \_\_\_\_\_  
 UTM \_\_\_\_\_ Q \_\_\_\_\_ NR \_\_\_\_\_ SHL \_\_\_\_\_  
 Lat \_\_\_\_\_ Lon \_\_\_\_\_ Era \_\_\_\_\_ Sig \_\_\_\_\_  
 Adm \_\_\_\_\_ T2 \_\_\_\_\_ T3 \_\_\_\_\_ Cat \_\_\_\_\_ HABS \_\_\_\_\_ HAER \_\_\_\_\_ Fed \_\_\_\_\_

**IDENTIFICATION Cat. IV**

- Common name: \_\_\_\_\_
  - Historic name, if known: \_\_\_\_\_
  - Street or rural address 942 Ramona Street  
 City: Palo Alto ZIP: \_\_\_\_\_ County: Santa Clara
  - Present owner, if known: Melvyn and Saisie Pratt Address: 1136 Waverley Street  
 City: Palo Alto, Ca 94301 ZIP: \_\_\_\_\_ Ownership is: Public  Private
  - Present Use: Residential Original Use: Residential
- Other past uses: \_\_\_\_\_

**DESCRIPTION**

- Briefly describe the present physical appearance of the site or structure and describe any major alterations from its original condition:

**A severe two-story house with minimal stylistic gestures of fish-scale shingle pattern in the gable above the bay window. It is nearly a twin to 948 Ramona Street. The perch has been enclosed.**

- Locational sketch map (draw and label site and surrounding streets, roads, and prominent landmarks):

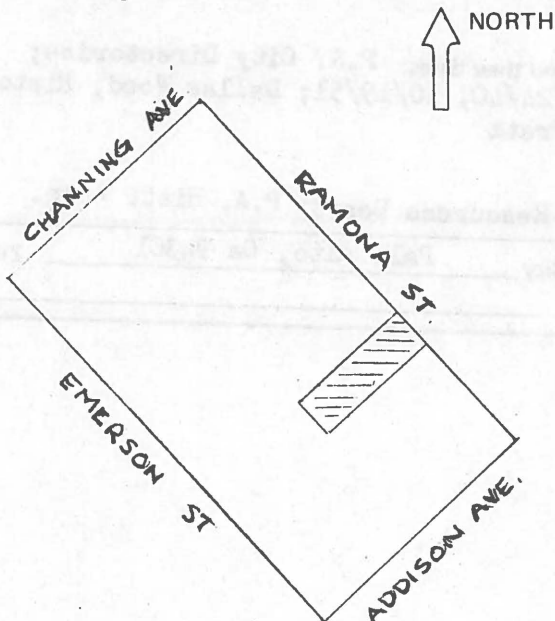

- Approximate property size:  
 Lot size (in feet) Frontage 37.5  
 Depth 112.5  
 or approx. acreage \_\_\_\_\_
- Condition: (check one)  
 a. Excellent  b. Good  c. Fair   
 d. Deteriorated  e. No longer in existence
- Is the feature a. Altered?  b. Unaltered?
- Surroundings: (Check more than one if necessary)  
 a. Open land  b. Scattered buildings   
 c. Densely built-up  d. Residential   
 e. Commercial  f. Industrial   
 g. Other  \_\_\_\_\_
- Threats to site:  
 a. None known  b. Private development   
 c. Zoning  d. Public Works project   
 e. Vandalism  f. Other  \_\_\_\_\_
- Date(s) of enclosed photograph(s): 1978



942 Ramona

NOTE: The following (Items 14-19) are for structures only.

14. Primary exterior building material: a. Stone  b. Brick  c. Stucco  d. Adobe  e. Wood   
f. Other
15. Is the structure: a. On its original site?  b. Moved?  c. Unknown?
16. Year of initial construction 1904 This date is: a. Factual  b. Estimated
17. Architect (if known): \_\_\_\_\_
18. Builder (if known): A.W. Caulkins
19. Related features: a. Barn  b. Carriage house  c. Outhouse  d. Shed(s)  e. Formal garden(s)   
f. Windmill  g. Watertower/tankhouse  h. Other  i. None

SIGNIFICANCE

20. Briefly state historical and/or architectural importance (include dates, events, and persons associated with the site when known):  
A severe example of the vernacular interpretation of Queen Anne style. Apparently it and its near-twin neighbor at 948 Ramona (as well as its other neighbor, originally the Henry E. Pratt house at 934 Ramona) were unoccupied for a short time, then sold to their first owners in 1906. Elisha and Arthur Dickinson, lumbermen, acquired the house at 942 Ramona and occupied until 1909. It then became the home of Mrs. Rachel Couch and her son William. Mrs. Couch was the widow of Capt. Thomas Couch. Both were natives of Wales. She was brought as a child to California and, in 1873, married Couch, one of the Cornish miners drawn to the Far Western mines in Montana and California. After his death in 1902, she moved from San Francisco to Palo Alto. One of her sons, E.J. Couch, established Palo Alto's first steam laundry about 1898, but later left to go into farming in the Sacramento Valley. William Couch, trained as an engineer, died in France in 1917 while serving with the American Expeditionary Force. The next owner was Mrs. Katherine Hibasco (to 1961) and her children; she was a native of Hungary. Since 1961 the house has been divided and rented as an apartment building.
21. Main theme of the historic resource: (Check only one): a. Architecture  b. Arts & Leisure   
c. Economic/Industrial  d. Exploration/Settlement  e. Government  f. Military   
g. Religion  h. Social/Education
22. Sources: List books, documents, surveys, personal interviews, and their dates: P.A. City Directories; P.A. Times 12/30/04, 11/26/06, 10/10/18, 2/24/40, 10/19/51; Dallas Wood, History of Palo Alto, 248; interview 1985, Melvyn Pratt

23. Date form prepared: 1978, 1985 By (name): Historic Resources Board; P.A. Hist. Assn.  
Address: 250 Hamilton Ave City Palo Alto, Ca 94301 ZIP: \_\_\_\_\_  
Phone: \_\_\_\_\_ Organization: \_\_\_\_\_

(State Use Only)

HISTORIC RESOURCES INVENTORY

(State use only)  
 Ser \_\_\_\_\_ Site \_\_\_\_\_ Mo. \_\_\_\_\_ Yr. \_\_\_\_\_  
 UTM \_\_\_\_\_ Q \_\_\_\_\_ NR \_\_\_\_\_ SHL \_\_\_\_\_  
 Lat \_\_\_\_\_ Lon \_\_\_\_\_ Era \_\_\_\_\_ Sig \_\_\_\_\_  
 Adm \_\_\_\_\_ T2 \_\_\_\_\_ T3 \_\_\_\_\_ Cat \_\_\_\_\_ HABS \_\_\_\_\_ HAER \_\_\_\_\_ Fed \_\_\_\_\_

IDENTIFICATION Cat. IV

- Common name: \_\_\_\_\_
- Historic name, if known: \_\_\_\_\_
- Street or rural address: 948 Ramona Street  
 City: Palo Alto ZIP: \_\_\_\_\_ County: Santa Clara
- Present owner, if known: Barry and Marga St. John Address: PO Box 1131  
 City: Menlo Park, Ca 94025 ZIP: \_\_\_\_\_ Ownership is: Public  Private
- Present Use: Residential Original Use: Residential  
 Other past uses: \_\_\_\_\_

DESCRIPTION

- Briefly describe the present physical appearance of the site or structure and describe any major alterations from its original condition:  
The two-story bay-windowed house in Queen Anne style, is a severe and almost un-decorated near twin of the house next door (948 Ramona St.). Its painted trim, however, gives it greater impact, visually.

- Locational sketch map (draw and label site and surrounding streets, roads, and prominent landmarks):

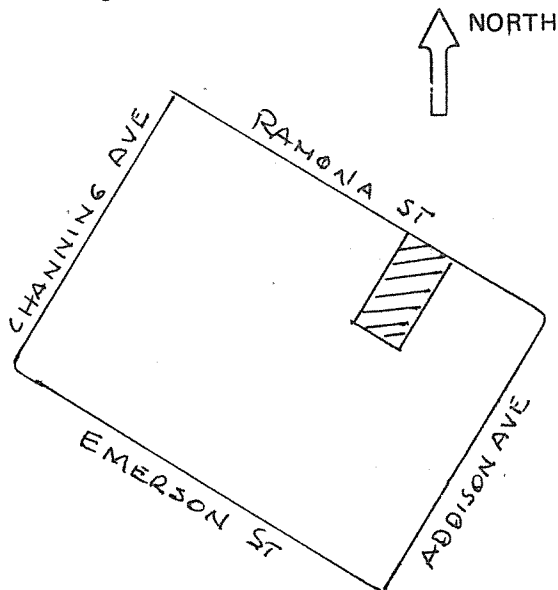

- Approximate property size:  
 Lot size (in feet) Frontage 37.5  
 Depth 112.5  
 or approx. acreage \_\_\_\_\_
- Condition: (check one)  
 a. Excellent  b. Good  c. Fair   
 d. Deteriorated  e. No longer in existence
- Is the feature a. Altered?  b. Unaltered?
- Surroundings: (Check more than one if necessary)  
 a. Open land  b. Scattered buildings   
 c. Densely built-up  d. Residential   
 e. Commercial  f. Industrial   
 g. Other
- Threats to site:  
 a. None known  b. Private development   
 c. Zoning  d. Public Works project   
 e. Vandalism  f. Other
- Date(s) of enclosed photograph(s): 1978

NOTE: The following (Items 14-19) are for structures only.

14. Primary exterior building material: a. Stone  b. Brick  c. Stucco  d. Adobe  e. Wood   
f. Other
15. Is the structure: a. On its original site?  b. Moved?  c. Unknown?
16. Year of initial construction 1904 This date is: a. Factual  b. Estimated
17. Architect (if known): \_\_\_\_\_
18. Builder (if known): A.W. Caulkins or H.L. Upham
19. Related features: a. Barn  b. Carriage house  c. Outhouse  d. Shed(s)  e. Formal garden(s)   
f. Windmill  g. Watertower/tankhouse  h. Other  i. None

## SIGNIFICANCE

20. Briefly state historical and/or architectural importance (include dates, events, and persons associated with the site when known):

A good example of a vernacular version of the Queen Anne mode. (See also note on 942 Ramona Street). Its first occupants were Mr. and Mrs. S. Carter, followed after 1914 by a number of short-term residents. From 1923-39 it was the home of Jerome and Elva Hollingsworth; he was a grocer. Then, in 1940, Mrs. Reva Street bought the house; she re-married in 1941 to Frank M. Price, a carpenter, and the Prices kept the house until 1975, when the present owners acquired it.

21. Main theme of the historic resource: (Check only one): a. Architecture  b. Arts & Leisure   
c. Economic/Industrial  d. Exploration/Settlement  e. Government  f. Military   
g. Religion  h. Social/Education

22. Sources: List books, documents, surveys, personal interviews, and their dates: P.A. City Directories; P.A. Times 12/30/04, 12/29/24, 1/30/40, 1/4/75; interview 1985, Melvyn Pratt

23. Date form prepared: 1978, 1985 By (name): Historic Resources Board; P.A. Hist. Assn.  
Address: 250 Hamilton Ave City Palo Alto, Ca ZIP: 94301  
Phone: \_\_\_\_\_ Organization: \_\_\_\_\_

(State Use Only)

HISTORIC RESOURCES INVENTORY

(State use or  
UTM \_\_\_\_\_ Q \_\_\_\_\_ NR \_\_\_\_\_ SHL \_\_\_\_\_  
Lat \_\_\_\_\_ Lon \_\_\_\_\_ Era \_\_\_\_\_ Sig \_\_\_\_\_  
Adm \_\_\_\_\_ T2 \_\_\_\_\_ T3 \_\_\_\_\_ Cat \_\_\_\_\_ HABS \_\_\_\_\_ HAER \_\_\_\_\_ ed \_\_\_\_\_

IDENTIFICATION Cat. III

1. Common name: \_\_\_\_\_
2. Historic name, if known: \_\_\_\_\_
3. Street or rural address 1001 Ramona Avenue  
City: Palo Alto ZIP: \_\_\_\_\_ County: Santa Clara
4. Present owner, if known: Peter Vilkin Address: 2318 Oberlin Street  
City: Palo Alto, Ca 94306 ZIP: \_\_\_\_\_ Ownership is: Public  Private
5. Present Use: Duplex Original Use: Residential  
Other past uses: \_\_\_\_\_

DESCRIPTION

6. Briefly describe the present physical appearance of the site or structure and describe any major alterations from its original condition:

The arched openings and layered effect of the front porch are unusual in what is an otherwise letter-perfect plan book bungalow. The generous front porch and the shed dormer are more typical of the type, as is the ground-hugging profile.

7. Locational sketch map (draw and label site and surrounding streets, roads, and prominent landmarks):

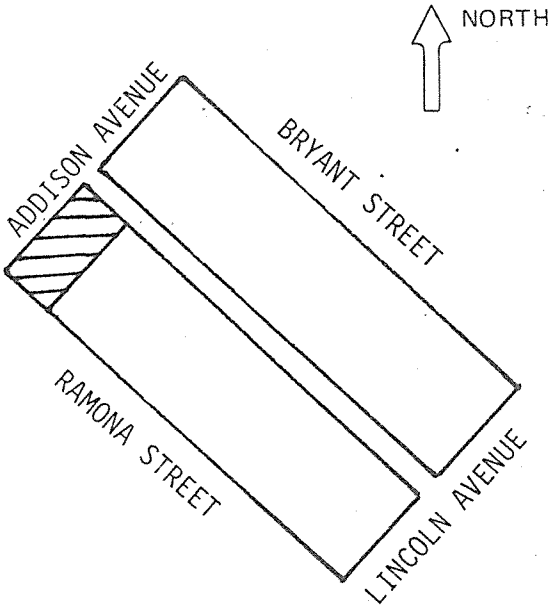

8. Approximate property size:  
Lot size (in feet) Frontage 50  
Depth 105  
or approx. acreage \_\_\_\_\_
9. Condition: (check one)  
a. Excellent  b. Good  c. Fair   
d. Deteriorated  e. No longer in existence
10. Is the feature a. Altered?  b. Unaltered?
11. Surroundings: (Check more than one if necessary)  
a. Open land  b. Scattered buildings   
c. Densely built-up  d. Residential   
e. Commercial  f. Industrial   
g. Other  \_\_\_\_\_
12. Threats to site:  
a. None known  b. Private development   
c. Zoning  d. Public Works project   
e. Vandalism  f. Other  \_\_\_\_\_
13. Date(s) of enclosed photograph(s): 1978

NOTE: The following (Items 14-19) are for structures only.

14. Primary exterior building material: a. Stone  b. Brick  c. Stucco  d. Adobe  e. Wood   
Other  \_\_\_\_\_
15. Is the structure: a. On its original site?  b. Moved?  c. Unknown?
16. Year of initial construction 1908 This date is: a. Factual  b. Estimated
17. Architect (if known): \_\_\_\_\_
18. Builder (if known): Gustav Laumeister
19. Related features: a. Barn  b. Carriage house  c. Outhouse  d. Shed(s)  e. Formal garden(s)   
f. Windmill  g. Watertower/tankhouse  h. Other  \_\_\_\_\_ i. None

## SIGNIFICANCE

20. Briefly state historical and/or architectural importance (include dates, events, and persons associated with the site when known):

This is an unusually elegant and unexpectedly detailed Craftsman bungalow, built for Mrs. W.H. Fowler (see 221 Kingsley and 1129 Emerson) by her usual contractor, Laumeister. Its first owners were Professor and Mrs. A.M. Cathcart (1910-1917). A graduate of Stanford with a Harvard law degree, Professor Cathcart (1873-1949) joined the Stanford law school faculty in 1904, taught at the University until 1938, and then topped off a distinguished career by teaching at Hastings Law School until his death. He was one of the most active Stanford faculty members who participated in Palo Alto community affairs --seventeen years as a City Councilman (1918-1936), and mayor during the last four of those years. From 1925 to 1942 the house belonged to Elmer B. Crady and, after his death, his widow Mrs. Margaret F. Crady. Mrs. Myrtle Appy was the owner and occupant from 1944-1985. She came to Palo Alto from Redwood City, where she lived from 1922-1944. She was a graduate of Columbia Teachers College and taught school in Cleveland before coming to California.

21. Main theme of the historic resource: (Check only one): a. Architecture  b. Arts & Leisure   
c. Economic/Industrial  d. Exploration/Settlement  e. Government  f. Military   
g. Religion  h. Social/Education
22. Sources: List books, documents, surveys, personal interviews, and their dates:  
Palo Alto City Directories; P.A. Times 3/20/08, 12/24/08, 11/2/49, 1/18/74, 1/22/85;  
Guy C. Miller, Palo Alto Community Book (P.A. 1952), p. 240
23. Date form prepared: 1981, 1986 By (name): Historic Resources Board; P.A. Hist. Assn.  
Address: 250 Hamilton Avenue City Palo Alto, Ca 94301 ZIP: \_\_\_\_\_  
Phone: \_\_\_\_\_ Organization: \_\_\_\_\_

(State Use Only)

HISTORIC RESOURCES INVENTORY

(State use)  
 DTM \_\_\_\_\_ U \_\_\_\_\_ SVN \_\_\_\_\_ CRTL \_\_\_\_\_  
 Lat \_\_\_\_\_ Lon \_\_\_\_\_ Era \_\_\_\_\_ Sig \_\_\_\_\_  
 Adm \_\_\_\_\_ T2 \_\_\_\_\_ T3 \_\_\_\_\_ Cat \_\_\_\_\_ HABS \_\_\_\_\_ HAER \_\_\_\_\_ Fed \_\_\_\_\_

IDENTIFICATION **Cat. IV**

1. Common name: \_\_\_\_\_
2. Historic name, if known: \_\_\_\_\_
3. Street or rural address 1021 Ramona Street  
 City: Palo Alto ZIP: \_\_\_\_\_ County: Santa Clara
4. Present owner, if known: Jerome and Sandra Peters Address: Same  
 City: \_\_\_\_\_ ZIP: \_\_\_\_\_ Ownership is: Public  Private
5. Present Use: Residence Original Use: Residence  
 Other past uses: \_\_\_\_\_

DESCRIPTION

6. Briefly describe the present physical appearance of the site or structure and describe any major alterations from its original condition:

The structures at 1021 and 1029 Ramona Street offer an excellent example of the difference that paint color can make in the visual appearance of a building. The two houses are, in fact, identical in form, plan, and material. The restrained Colonial Revival design features generous front porches supported by Tuscan columns. The most interesting design item is the abstract fenestration pattern on the second floor. Together, they are typical of small-scale development at the turn of the century and are parts of a coherent block face, as well.

7. Locational sketch map (draw and label site and surrounding streets, roads, and prominent landmarks):

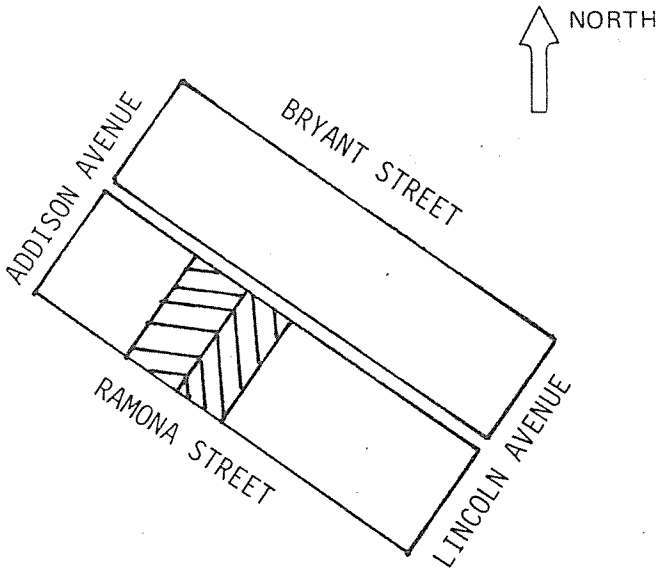

8. Approximate property size:  
 Lot size (in feet) Frontage 50  
 Depth 105  
 or approx. acreage \_\_\_\_\_
9. Condition: (check one)  
 a. Excellent  b. Good  c. Fair   
 d. Deteriorated  e. No longer in existence
10. Is the feature a. Altered?  b. Unaltered?
11. Surroundings: (Check more than one if necessary)  
 a. Open land  b. Scattered buildings   
 c. Densely built-up  d. Residential   
 e. Commercial  f. Industrial   
 g. Other  \_\_\_\_\_
12. Threats to site:  
 a. None known  b. Private development   
 c. Zoning  d. Public Works project   
 e. Vandalism  f. Other  \_\_\_\_\_

13. Date(s) of enclosed photograph(s): 1978

1021 Ramona

NOTE: The following (Items 14-19) are for structures only.

14. Primary exterior building material: a. Stone  b. Brick  c. Stucco  d. Adobe  e. Wood   
f. Other

15. Is the structure: a. On its original site?  b. Moved?  c. Unknown?

16. Year of initial construction 1905 This date is: a. Factual  b. Estimated

17. Architect (if known): \_\_\_\_\_

18. Builder (if known): \_\_\_\_\_

19. Related features: a. Barn  b. Carriage house  c. Outhouse  d. Shed(s)  e. Formal garden(s)   
f. Windmill  g. Watertower/tankhouse  h. Other  i. None

SIGNIFICANCE

20. Briefly state historical and/or architectural importance (include dates, events, and persons associated with the site when known):

First occupied by Mrs. E. Melcer and her daughter, from 1911 to 1952 it was the home of Franklin P. and Lola F. Steinmetz. They moved to Palo Alto from Carson City, where Mr. Steinmetz had been a pharmacist for twenty-five years. Here he operated the University Pharmacy in downtown Palo Alto.

Subsequent owners included Professor and Mrs. Lincoln E. Moser, of Stanford; the Sam H.N. Tharp family; and Stratton Wynkoop, of Stanford Research Insitutue. The present owners occupied the house in the mid-seventies.

21. Main theme of the historic resource: (Check only one): a. Architecture  b. Arts & Leisure   
c. Economic/Industrial  d. Exploration/Settlement  e. Government  f. Military   
g. Religion  h. Social/Education

22. Sources: List books, documents, surveys, personal interviews, and their dates:

Palo Alto City Directories; Palo Alto Times, 4/29/10, 10/1/32

23. Date form prepared: 1981 By (name): Historic Resources Board  
Address: 250 Hamilton Ave City Palo Alto, Ca 94301 ZIP: \_\_\_\_\_  
Phone: \_\_\_\_\_ Organization: \_\_\_\_\_

(State Use Only)



HISTORIC RESOURCES INVENTORY

(State use or  
UTM \_\_\_\_\_ Q \_\_\_\_\_ NR \_\_\_\_\_ SHL \_\_\_\_\_  
Lat \_\_\_\_\_ Lon \_\_\_\_\_ Era \_\_\_\_\_ Sig \_\_\_\_\_  
Adm \_\_\_\_\_ T2 \_\_\_\_\_ T3 \_\_\_\_\_ Cat \_\_\_\_\_ HABS \_\_\_\_\_ HAER \_\_\_\_\_ Fed \_\_\_\_\_

IDENTIFICATION Cat. IV

1. Common name: \_\_\_\_\_
2. Historic name, if known: \_\_\_\_\_
3. Street or rural address 1024 Ramona Street  
City: Palo Alto ZIP: \_\_\_\_\_ County: Santa Clara
4. Present owner, if known: Lewis Morrow Address: Same  
City: \_\_\_\_\_ ZIP: \_\_\_\_\_ Ownership is: Public  Private
5. Present Use: Residence Original Use: \_\_\_\_\_  
Other past uses: Triplex

DESCRIPTION

6. Briefly describe the present physical appearance of the site or structure and describe any major alterations from its original condition:

This modest Craftsman bungalow is made elegant by its carefully detailed string course and downstairs window detailing. The awkward proportions of the front-facing dormer indicate that it may be a later addition.

7. Locational sketch map (draw and label site and surrounding streets, roads, and prominent landmarks):

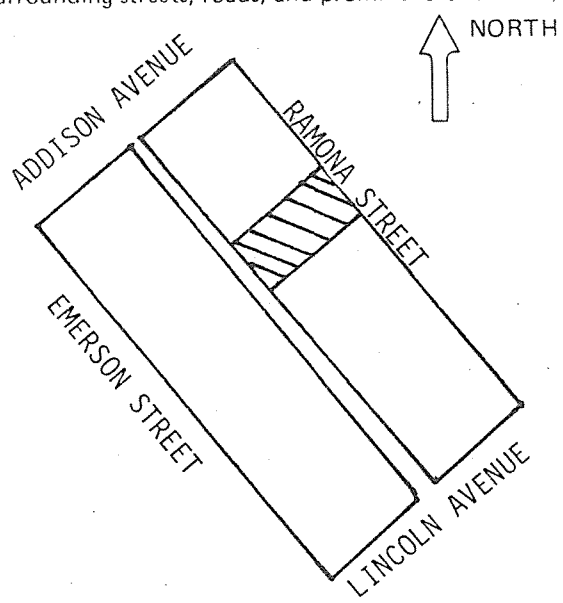

8. Approximate property size:  
Lot size (in feet) Frontage 50  
Depth 105;  
or approx. acreage \_\_\_\_\_.
9. Condition: (check one)  
a. Excellent  b. Good  c. Fair   
d. Deteriorated  e. No longer in existence
10. Is the feature a. Altered?  b. Unaltered?
11. Surroundings: (Check more than one if necessary)  
a. Open land  b. Scattered buildings   
c. Densely built-up  d. Residential   
e. Commercial  f. Industrial   
g. Other
12. Threats to site:  
a. None known  b. Private development   
c. Zoning  d. Public Works project   
e. Vandalism  f. Other
13. Date(s) of enclosed photograph(s): 1978



NOTE: The following (Items 14-19) are for structures only.

14. Primary exterior building material: a. Stone  b. Brick  c. Stucco  d. Adobe  e. Wood   
 f. Other  \_\_\_\_\_
15. Is the structure: a. On its original site?  b. Moved?  c. Unknown?
16. Year of initial construction 1914 This date is: a. Factual  b. Estimated
17. Architect (if known): \_\_\_\_\_
18. Builder (if known): \_\_\_\_\_
19. Related features: a. Barn  b. Carriage house  c. Outhouse  d. Shed(s)  e. Formal garden(s)   
 f. Windmill  g. Watertower/tankhouse  h. Other  \_\_\_\_\_ i. None

## SIGNIFICANCE

20. Briefly state historical and/or architectural importance (include dates, events, and persons associated with the site when known):

This is a fine example of the modest, probably builder-designed, Craftsman bungalow. It was built for the local banker, D.W. Buchan, as investment property and immediately occupied by Dr. and Mrs. Halbert W. Chappel. Soon, however, it became the long-time (1919-1940) home of Elmer J. Worth, proprietor of a grocery, and his family. Later owners in the mid-century converted it for use as a duplex or triplex, but the present owners returned it to single-family use in the mid-seventies.

21. Main theme of the historic resource: (Check only one): a. Architecture  b. Arts & Leisure   
 c. Economic/Industrial  d. Exploration/Settlement  e. Government  f. Military   
 g. Religion  h. Social/Education

22. Sources: List books, documents, surveys, personal interviews, and their dates:  
 Palo Alto City Directories; Palo Alto Times, 1/5/15; 4/30/55.

23. Date form prepared: 1981 By (name): Historic Resources Board  
 Address: 250 Hamilton Avenue City Palo Alto, Ca 94301 ZIP: \_\_\_\_\_  
 Phone: \_\_\_\_\_ Organization: \_\_\_\_\_

(State Use Only)

HISTORIC RESOURCES INVENTORY

(State use only)  
 UTM \_\_\_\_\_ Q \_\_\_\_\_ NR \_\_\_\_\_ SHL \_\_\_\_\_  
 Lat \_\_\_\_\_ Lon \_\_\_\_\_ Era \_\_\_\_\_ Sig \_\_\_\_\_  
 Adm \_\_\_\_\_ T2 \_\_\_\_\_ T3 \_\_\_\_\_ Cat \_\_\_\_\_ HABS \_\_\_\_\_ HAER \_\_\_\_\_ Fed \_\_\_\_\_

IDENTIFICATION Cat. IV

1. Common name: \_\_\_\_\_
2. Historic name, if known: \_\_\_\_\_
3. Street or rural address 1029 Ramona Street  
 City: Palo Alto ZIP: 94301 County: Santa Clara
4. Present owner, if known: Richard Beckett Address: Same  
 City: \_\_\_\_\_ ZIP: \_\_\_\_\_ Ownership is: Public  Private
5. Present Use: Residence Original Use: Residence  
 Other past uses: \_\_\_\_\_

DESCRIPTION

6. Briefly describe the present physical appearance of the site or structure and describe any major alterations from its original condition:

The structures at 1021 and 1029 Ramona Street offer an excellent example of the difference that paint color can make in the visual appearance of a building. The two houses are, in fact, identical in form, plan, and material. The restrained Colonial Revival design features generous front porches supported by Tuscan columns. The most interesting design item is the abstract fenestration pattern on the second floor. Together, they are typical of small-scale development at the turn of the century and are parts of a coherent block face, as well.

7. Locational sketch map (draw and label site and surrounding streets, roads, and prominent landmarks):

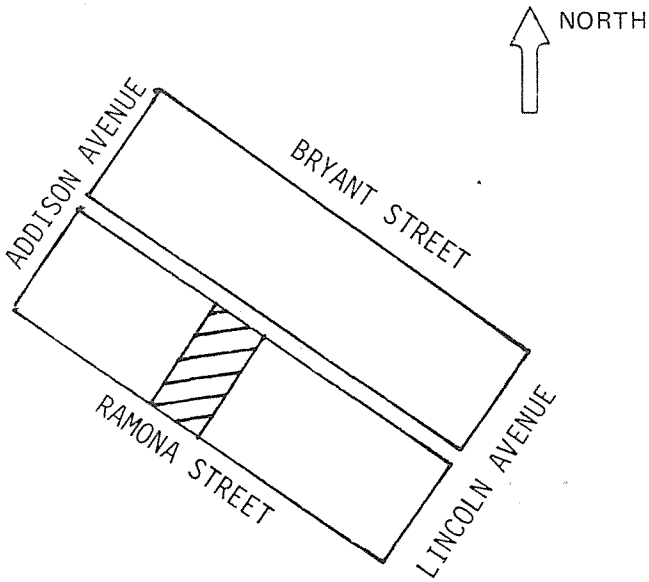

8. Approximate property size:

Lot size (in feet) Frontage 50  
 Depth 105  
 or approx. acreage \_\_\_\_\_

9. Condition: (check one)

- a. Excellent  b. Good  c. Fair   
 d. Deteriorated  e. No longer in existence

10. Is the feature a. Altered?  b. Unaltered?

11. Surroundings: (Check more than one if necessary)

- a. Open land  b. Scattered buildings   
 c. Densely built-up  d. Residential   
 e. Commercial  f. Industrial   
 g. Other  \_\_\_\_\_

12. Threats to site:

- a. None known  b. Private development   
 c. Zoning  d. Public Works project   
 e. Vandalism  f. Other  \_\_\_\_\_

13. Date(s) of enclosed photograph(s): 1978

NOTE: The following (Items 14-19) are for structures only.

14. Primary exterior building material: a. Stone  b. Brick  c. Stucco  d. Adobe  e. Wood   
f. Other
15. Is the structure: a. On its original site?  b. Moved?  c. Unknown?
16. Year of initial construction 1905 This date is: a. Factual  b. Estimated
17. Architect (if known): \_\_\_\_\_
18. Builder (if known): \_\_\_\_\_
19. Related features: a. Barn  b. Carriage house  c. Outhouse  d. Shed(s)  e. Formal garden(s)   
f. Windmill  g. Watertower/tankhouse  h. Other  i. None

## SIGNIFICANCE

20. Briefly state historical and/or architectural importance (include dates, events, and persons associated with the site when known):

First occupied by Mrs. R. Pieper, from 1911 to 1919 it was the home of Mrs. Emily M. Stauf and her daughter Ida. The latter, born in Germany in 1871, received the A.B. and M.A. degrees from Stanford, taught both here and abroad, and was a member of the Stanford Romance Languages Department from 1928 until her death in 1936. Professor Edwin A. and Louise H. Cottrell occupied it very briefly, and in 1920 it was purchased by Bergie B. and Lutie Beckett. Cottrell (1881-1953) was one of Stanford's most eminent political scientists, a Palo Alto mayor (1925-6), member of numerous community, state, and national councils and boards, and the chief architect of the City's new charter in 1949. Beckett was a well-established electrical engineer; he and his descendants retain the home until the present day.

21. Main theme of the historic resource: (Check only one): a. Architecture  b. Arts & Leisure   
c. Economic/Industrial  d. Exploration/Settlement  e. Government  f. Military   
g. Religion  h. Social/Education

22. Sources: List books, documents, surveys, personal interviews, and their dates:

Palo Alto City Directories; Palo Alto Times 9/6/17, 5/28/36, 2/10/53, 10/23/68; Stanford Reivew, April 1953.

23. Date form prepared: 1981 By (name): Historic Resources Board  
Address: 250 Hamilton Avenue City Palo Alto, Ca 94301 ZIP: \_\_\_\_\_  
Phone: \_\_\_\_\_ Organization: \_\_\_\_\_

(State Use Only)

HISTORIC RESOURCES INVENTORY

(State use or  
UTM \_\_\_\_\_ Q \_\_\_\_\_ NR \_\_\_\_\_ SHL \_\_\_\_\_  
Lat \_\_\_\_\_ Lon \_\_\_\_\_ Era \_\_\_\_\_ Sig \_\_\_\_\_  
Adm \_\_\_\_\_ T2 \_\_\_\_\_ T3 \_\_\_\_\_ Cat \_\_\_\_\_ HABS \_\_\_\_\_ HAER \_\_\_\_\_ Fed \_\_\_\_\_

IDENTIFICATION **Cat. IV**

1. Common name: \_\_\_\_\_
2. Historic name, if known: \_\_\_\_\_
3. Street or rural address 1047 Ramona Street (Professorville Historic District)  
City: Palo Alto ZIP: \_\_\_\_\_ County: Santa Clara
4. Present owner, if known: Arthur and June Holland Address: Same  
City: \_\_\_\_\_ ZIP: \_\_\_\_\_ Ownership is: Public  Private
5. Present Use: Residential Original Use: Residential  
Other past uses: \_\_\_\_\_

DESCRIPTION

6. Briefly describe the present physical appearance of the site or structure and describe any major alterations from its original condition:

This two-story Colonial Revival house is a restrained design whose formal symmetry and Doric porch columns comprise its stylistic image.

7. Locational sketch map (draw and label site and surrounding streets, roads, and prominent landmarks):

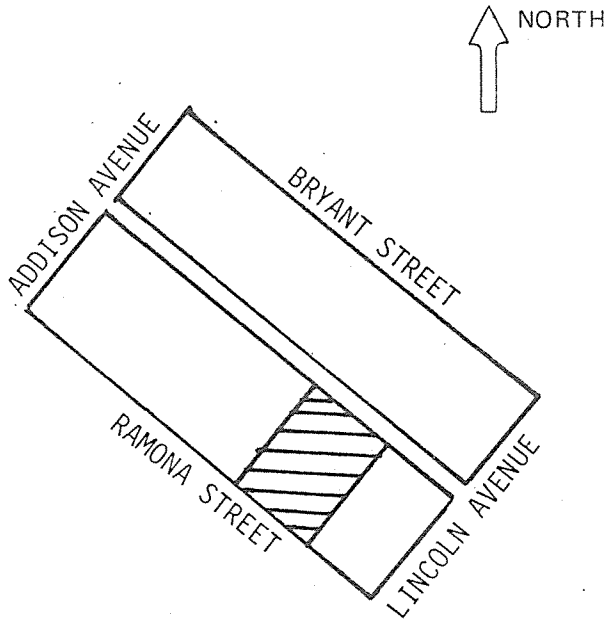

8. Approximate property size:  
Lot size (in feet) Frontage: 75  
Depth: 105;  
or approx. acreage \_\_\_\_\_.
9. Condition: (check one)  
a. Excellent  b. Good  c. Fair   
d. Deteriorated  e. No longer in existence
10. Is the feature a. Altered?  b. Unaltered?
11. Surroundings: (Check more than one if necessary)  
a. Open land  b. Scattered buildings   
c. Densely built-up  d. Residential   
e. Commercial  f. Industrial   
g. Other  \_\_\_\_\_
12. Threats to site:  
a. None known  b. Private development   
c. Zoning  d. Public Works project   
e. Vandalism  f. Other  \_\_\_\_\_
13. Date(s) of enclosed photograph(s): 1978

NOTE: The following (Items 14-19) are for structures only.

14. Primary exterior building material: a. Stone  b. Brick  c. Stucco  d. Adobe  e. Wood   
f. Other
15. Is the structure: a. On its original site?  b. Moved?  c. Unknown?
16. Year of initial construction 1907 This date is: a. Factual  b. Estimated
17. Architect (if known): \_\_\_\_\_
18. Builder (if known): \_\_\_\_\_
19. Related features: a. Barn  b. Carriage house  c. Outhouse  d. Shed(s)  e. Formal garden(s)   
f. Windmill  g. Watertower/tankhouse  h. Other  10-7-11 i. None

## SIGNIFICANCE

20. Briefly state historical and/or architectural importance (include dates, events, and persons associated with the site when known):

The earliest occupants were Mr. and Mrs. C. Graham; Graham was in the oil business. Professors Austin F. Rogers (1911-1919) and Harold Heath (1919-1921) next occupied it. Rogers was a significant geologist and Heath a zoologist of international repute. John W. Spratley, a salesman, and his wife May made it their home from 1921 to 1955. Short-term occupants followed until 1978, when it was acquired by the present owners.

21. Main theme of the historic resource: (Check only one): a. Architecture  b. Arts & Leisure   
c. Economic/Industrial  d. Exploration/Settlement  e. Government  f. Military   
g. Religion  h. Social/Education

22. Sources: List books, documents, surveys, personal interviews, and their dates:

P.A. City Directories; P.A. Times - 4/24/51, 3/11/57; Sanborn Co. Fire Insurance Map of Palo Alto, 1908 (P.A. Library)

23. Date form prepared: 1981, 1986 By (name): Historic Resources Board; P.A. Hist. Assn.  
Address: 250 Hamilton Ave City: Palo Alto, Ca 94301 ZIP: \_\_\_\_\_  
Phone: \_\_\_\_\_ Organization: \_\_\_\_\_

**HISTORIC RESOURCES INVENTORY**

(State use)  
 UTM \_\_\_\_\_ U \_\_\_\_\_ NR \_\_\_\_\_ SHL \_\_\_\_\_  
 Lat \_\_\_\_\_ Lon \_\_\_\_\_ Era \_\_\_\_\_ Sig \_\_\_\_\_  
 Adm \_\_\_\_\_ T2 \_\_\_\_\_ T3 \_\_\_\_\_ Cat \_\_\_\_\_ HABS \_\_\_\_\_ HAER \_\_\_\_\_ Fed \_\_\_\_\_

**IDENTIFICATION Cat. IV**

1. Common name: \_\_\_\_\_
2. Historic name, if known: \_\_\_\_\_
3. Street or rural address 1048 Ramona Street (Professorville Historic District)  
 City: Palo Alto ZIP: \_\_\_\_\_ County: Santa Clara
4. Present owner, if known: Linda L. Ludden Address: \_\_\_\_\_  
 City: \_\_\_\_\_ ZIP: \_\_\_\_\_ Ownership is: Public  Private
5. Present Use: Residential Original Use: Residential  
 Other past uses: \_\_\_\_\_

**DESCRIPTION**

6. Briefly describe the present physical appearance of the site or structure and describe any major alterations from its original condition:  

This simple vernacular Colonial Revival building is roofed by two intersecting gables. A wide front porch is supported by Doric columns; crisply detailed, boxed eaves and eave returns contribute to the Colonial Revival image.

7. Locational sketch map (draw and label site and surrounding streets, roads, and prominent landmarks):

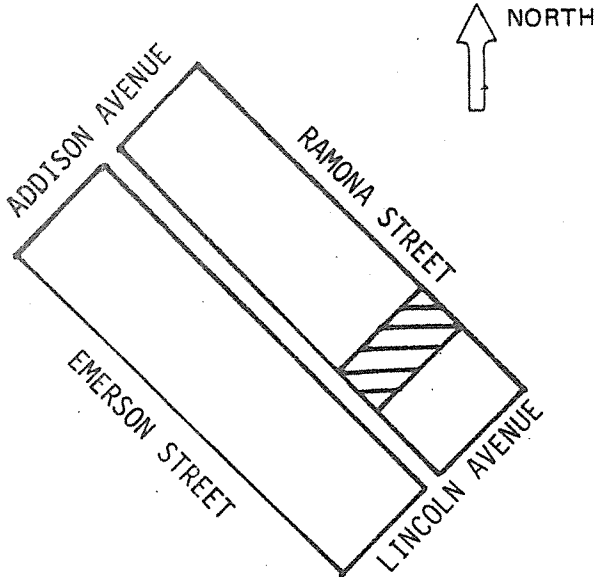

8. Approximate property size:  
 Lot size (in feet) Frontage 50  
 Depth 105  
 or approx. acreage \_\_\_\_\_
9. Condition: (check one)  
 a. Excellent  b. Good  c. Fair   
 d. Deteriorated  e. No longer in existence
10. Is the feature a. Altered?  b. Unaltered?
11. Surroundings: (Check more than one if necessary)  
 a. Open land  b. Scattered buildings   
 c. Densely built-up  d. Residential   
 e. Commercial  f. Industrial   
 g. Other
12. Threats to site:  
 a. None known  b. Private development   
 c. Zoning  d. Public Works project   
 e. Vandalism  f. Other
13. Date(s) of enclosed photograph(s): 1978

NOTE: The following (Items 14-19) are for structures only.

- 14. Primary exterior building material: a. Stone  b. Brick  c. Stucco  d. Adobe  e. Wood   
f. Other  \_\_\_\_\_
- 15. Is the structure: a. On its original site?  b. Moved?  c. Unknown?
- 16. Year of initial construction 1904 This date is: a. Factual  b. Estimated
- 17. Architect (if known): \_\_\_\_\_
- 18. Builder (if known): \_\_\_\_\_
- 19. Related features: a. Barn  b. Carriage house  c. Outhouse  d. Shed(s)  e. Formal garden(s)   
f. Windmill  g. Watertower/tankhouse  h. Other  \_\_\_\_\_ i. None

SIGNIFICANCE

20. Briefly state historical and/or architectural importance (include dates, events, and persons associated with the site when known):

This simple Colonial Revival house establishes its presence by the clarity of its form and the elegance of its detailing. Early occupants included Mr. and Mrs. F.S. Gifford, Mrs. E. Keen, and Mr. and Mrs. B. Carter. Professor Percy A. Martin, historian of Latin America, occupied it briefly (1913), as did Mr. and Mrs. Robert E. Hackley -- Hackley was a civil engineer, owner of pest control business, and long-time observer and critic of Palo Alto's City Council. It was owned for several years in the 1920s by the Howell W. Lownsbury family, and, from 1937 to 1949, by a local tailor, Edwin H. Johnson, who operated his shop from 1910 until shortly before his death in 1952. From 1953-1966, Kirk and Ruth Clagstone occupied the house, followed by short-term tenants until 1978, when it was acquired by the present owner.

- 21. Main theme of the historic resource: (Check only one): a. Architecture  b. Arts & Leisure   
c. Economic/Industrial  d. Exploration/Settlement  e. Government  f. Military   
g. Religion  h. Social/Education

22. Sources: List books, documents, surveys, personal interviews, and their dates:

P.A. Cit Directories; P.A. Times - 10/17/52, 1/21/58, 2/19/59.

23. Date form prepared: 1981 By (name): Historic Resources Board  
 Address: 250 Hamilton Ave City Palo Alto, Ca 94301 ZIP: \_\_\_\_\_  
 Phone: \_\_\_\_\_ Organization: \_\_\_\_\_

NR-4

(State Use Only)

--	--

HISTORIC RESOURCES INVENTORY

(State use of)

UTM \_\_\_\_\_ Q \_\_\_\_\_ NR \_\_\_\_\_ SHL \_\_\_\_\_  
 Lat \_\_\_\_\_ Lon \_\_\_\_\_ Era \_\_\_\_\_ Sig \_\_\_\_\_  
 Adm \_\_\_\_\_ T2 \_\_\_\_\_ T3 \_\_\_\_\_ Cat \_\_\_\_\_ HABS \_\_\_\_\_ HAER \_\_\_\_\_ Fed \_\_\_\_\_

IDENTIFICATION Cat. IV

- Common name: \_\_\_\_\_
- Historic name, if known: \_\_\_\_\_
- Street or rural address 1057 Ramona (Professorville Historic District)  
 City: Palo Alto ZIP: \_\_\_\_\_ County: Santa Clara
- Present owner, if known: Ken Alzman and Linda Scott Address: Same  
 City: \_\_\_\_\_ ZIP: \_\_\_\_\_ Ownership is: Public  Private
- Present Use: Residential Original Use: Residential  
 Other past uses: \_\_\_\_\_

DESCRIPTION

- Briefly describe the present physical appearance of the site or structure and describe any major alterations from its original condition:

This simple shingled box is decorated by a wider band of shingles at the second floor and a Tuscan porch which originally ran the full width of the house.

The side of the house has a projecting square bay, two stories in height and a series of additive structures to the rear which inventively accommodate an ancient oak. The square bays are supported at both stories by round ended short corbels.

In 1985 it was wholly rehabilitated and relandscaped. The rear entry was enlarged and decked, a dead oak was removed, a side entry added, and French doors or windows were substituted or introduced--all in compatible style.

- Locational sketch map (draw and label site and surrounding streets, roads, and prominent landmarks):

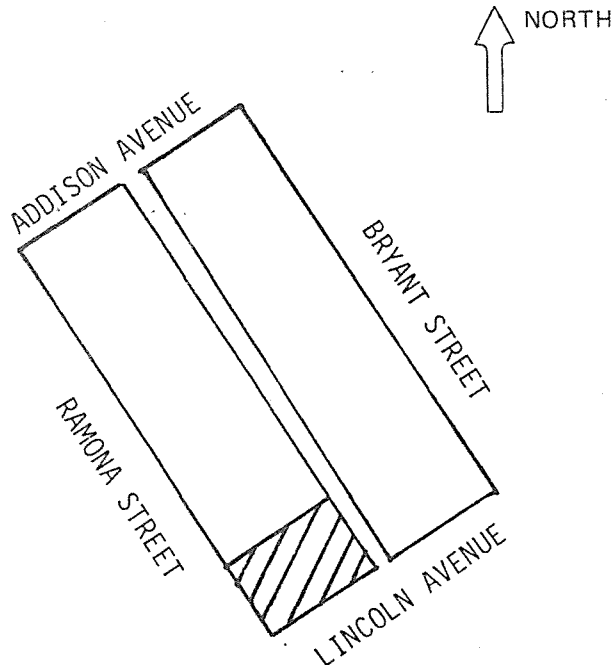

- Approximate property size:  
 Lot size (in feet) Frontage 75'  
 Depth 105'  
 or approx. acreage \_\_\_\_\_
- Condition: (check one)  
 a. Excellent  b. Good  c. Fair   
 d. Deteriorated  e. No longer in existence
- Is the feature a. Altered?  b. Unaltered?
- Surroundings: (Check more than one if necessary)  
 a. Open land  b. Scattered buildings   
 c. Densely built-up  d. Residential   
 e. Commercial  f. Industrial   
 g. Other
- Threats to site:  
 a. None known  b. Private development   
 c. Zoning  d. Public Works project   
 e. Vandalism  f. Other

13. Date(s) of enclosed photograph(s): 1978



NOTE: The following (Items 14-19) are for structures only.

14. Primary exterior building material: a. Stone  b. Brick  c. Stucco  d. Adobe  e. Wood   
f. Other
15. Is the structure: a. On its original site?  b. Moved?  c. Unknown?
16. Year of initial construction 1901 This date is: a. Factual  b. Estimated
17. Architect (if known): \_\_\_\_\_
18. Builder (if known): Gus Laumeister?; 1985 rehabilitation and remodeling, Scott Design Associates
19. Related features: a. Barn  b. Carriage house  c. Outhouse  d. Shed(s)  e. Formal garden(s)   
f. Windmill  g. Watertower/tankhouse  h. Other  i. None

## SIGNIFICANCE

20. Briefly state historical and/or architectural importance (include dates, events, and persons associated with the site when known):

First occupied (to 1908) by Professor and Mrs. H.W. Rolfe and Mrs. Anne D. Connelly, a musician, then (1908-1917) by Professor and Mrs. Edward C. Franklin. Franklin was an internationally-known expert in organic chemistry who joined the Stanford faculty in 1898. Elizabeth Hadden, sister of Palo Alto's first librarian Anne Hadden, lived there very briefly (1917-1918), as did an early Unitarian minister, Bradley Gilman and his wife Mary (1918-1919), and Professor and Mrs. Alfred D. Browne (a physician on the Stanford faculty, 1919-1922). For almost fifty years (1924-1972), it was the home of Charles and Martha Ellet (1884-1971). Ellet's father came to the City in 1908, bought the Mayfield Bank and Trust and later reorganized it as the Stanford Bank (subsequently sold to American Trust Co.). Ellet opened the Stanford Realty Co. in 1924 and thenceforth was a leading realtor in the community. It was the Ellet house until 1974, when it was acquired by John and Johanna Dunn, followed in 1985 by the present owners.

21. Main theme of the historic resource: (Check only one): a. Architecture  b. Arts & Leisure   
c. Economic/Industrial  d. Exploration/Settlement  e. Government  f. Military   
g. Religion  h. Social/Education

22. Sources: List books, documents, surveys, personal interviews, and their dates: P.A. City Directories;  
P.A. Times, 1/3/02, 10/21/28, 2/13/37, 5/5/44, 3/6/52, 9/27/71.

23. Date form prepared: 1981, 1985 By (name): Historic Resources Board; P.A. Hist. Assn.  
Address: 250 Hamilton Ave City Palo Alto, Ca 94301 ZIP: \_\_\_\_\_  
Phone: \_\_\_\_\_ Organization: \_\_\_\_\_

NR-4

(State Use Only)

HISTORIC RESOURCES INVENTORY

(State use only)

UTM \_\_\_\_\_ O \_\_\_\_\_ NR \_\_\_\_\_ SHL \_\_\_\_\_  
 Lat \_\_\_\_\_ Lon \_\_\_\_\_ Era \_\_\_\_\_ Sig \_\_\_\_\_  
 Adm \_\_\_\_\_ T2 \_\_\_\_\_ T3 \_\_\_\_\_ Cat \_\_\_\_\_ HABS \_\_\_\_\_ HAER \_\_\_\_\_ Fed \_\_\_\_\_

IDENTIFICATION Cat. III

1. Common name: \_\_\_\_\_
2. Historic name, if known: \_\_\_\_\_
3. Street or rural address 1103 Ramona Street  
 City: Palo Alto ZIP: \_\_\_\_\_ County: Santa Clara
4. Present owner, if known: Howard J. Gopen Address: \_\_\_\_\_  
 City: \_\_\_\_\_ ZIP: \_\_\_\_\_ Ownership is: Public  Private
5. Present Use: Residential Original Use: Residential  
 Other past uses: \_\_\_\_\_

DESCRIPTION

6. Briefly describe the present physical appearance of the site or structure and describe any major alterations from its original condition:  
  
 Despite decorative alterations at the entrance and a major expansion in the rear, this simple shingle version of Colonial Revival style retains its essential character. Its interest is less in its individual features than as an important component of a harmonious streetscape.

7. Locational sketch map (draw and label site and surrounding streets, roads, and prominent landmarks):

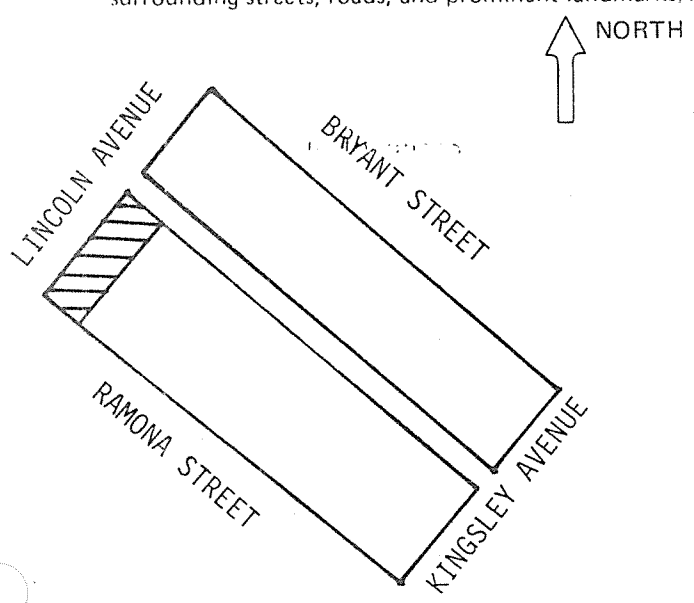

8. Approximate property size:  
 Lot size (in feet) Frontage 50  
 Depth 105;  
 or approx. acreage \_\_\_\_\_.
9. Condition: (check one)  
 a. Excellent  b. Good  c. Fair   
 d. Deteriorated  e. No longer in existence
10. Is the feature a. Altered?  b. Unaltered?
11. Surroundings: (Check more than one if necessary)  
 a. Open land  b. Scattered buildings   
 c. Densely built-up  d. Residential   
 e. Commercial  f. Industrial   
 g. Other
12. Threats to site:  
 a. None known  b. Private development   
 c. Zoning  d. Public Works project   
 e. Vandalism  f. Other
13. Date(s) of enclosed photograph(s): 1978

NOTE: The following (Items 14-19) are for structures only.

14. Primary exterior building material: a. Stone  b. Brick  c. Stucco  d. Adobe  e. Wood   
 f. Other  \_\_\_\_\_
15. Is the structure: a. On its original site?  b. Moved?  c. Unknown?
16. Year of initial construction 1901 This date is: a. Factual  b. Estimated
17. Architect (if known): \_\_\_\_\_
18. Builder (if known): Gus Laumeister
19. Related features: a. Barn  b. Carriage house  c. Outhouse  d. Shed(s)  e. Formal garden(s)   
 f. Windmill  g. Watertower/tankhouse  h. Other  \_\_\_\_\_ i. None

SIGNIFICANCE

20. Briefly state historical and/or architectural importance (include dates, events, and persons associated with the site when known):

Built for Professor and Mrs. C. A. Copeland of Stanford, the house was remembered by neighbors as the "Seale Cottage," due to the very early occupancy (1904-1908) by newlyweds Alfred and Grace Seale. Seale was the nephew of Thomas Seale, the landed entrepreneur who once owned much of the original Palo Alto townsite. Alfred was himself an investor, one of the Directors of the Bank of Palo Alto (later American Trust Co.), a president of the Chamber of Commerce, chairman of the Board of Public Safety, and a partner in the P.A. Improvement Co. Succeeding the Seales were Professor and Mrs. Henry David Gray (1908-1911)--Gray, an English professor, served on the Stanford faculty for thirty-one years--and Reginald H. McKaig, a banker, and sons Wallace and George. From 1915 to 1926, the house was occupied by the investment banker (Schwacher & Co.) and City Councilman (1931-1937) John S. Stephens and his wife Sadie. Then it became the home (1928-1968) of Merrill K. and Dorcas Bennett. Bennett was a food economist of international importance, heading up the University's Food Research Institute and often sitting on high governmental advisory commissions. An owner in recent times who carried out extensive remodeling was James E. Mitchell, a descendent of longtime University Registrar and civic leader J. Pearce Mitchell.

21. Main theme of the historic resource: (Check only one): a. Architecture  b. Arts & Leisure   
 c. Economic/Industrial  d. Exploration/Settlement  e. Government  f. Military   
 g. Religion  h. Social/Education

22. Sources: List books, documents, surveys, personal interviews, and their dates:

P.A. City Directories; P.A. Times - 1/3/02, 2/31/31, 3/25/33, 7/4/42, 6/28/46, 2/15/56, 2/4/58, 1/8/69, 9/25/75; Phyllis Butler, The Valley of Santa Clara.

23. Date form prepared: 1981 By (name): Historic Resources Board  
 Address: 250 Hamilton Avenue City Palo Alto, Ca 94301 ZIP: \_\_\_\_\_  
 Phone: \_\_\_\_\_ Organization: \_\_\_\_\_

(State Use Only)

HISTORIC RESOURCES INVENTORY

(State use only)

UTM \_\_\_\_\_ Q \_\_\_\_\_ NR \_\_\_\_\_ SHL \_\_\_\_\_  
 Lat \_\_\_\_\_ Lon \_\_\_\_\_ Era \_\_\_\_\_ Sig \_\_\_\_\_  
 Adm \_\_\_\_\_ T2 \_\_\_\_\_ T3 \_\_\_\_\_ Cat \_\_\_\_\_ HABS \_\_\_\_\_ HAER \_\_\_\_\_ Fed \_\_\_\_\_

IDENTIFICATION **Cat. II**

- Common name: \_\_\_\_\_
- Historic name, if known: \_\_\_\_\_
- Street or rural address 1115 Ramona Street (Professorville Historic District)  
 City: Palo Alto ZIP: 94301 County: Santa Clara
- Present owner, if known: Theodore G. and Adrian K. Erlor Address: Same  
 City: \_\_\_\_\_ ZIP: \_\_\_\_\_ Ownership is: Public  Private
- Present Use: Residential Original Use: Residential  
 Other past uses: \_\_\_\_\_

DESCRIPTION

- Briefly describe the present physical appearance of the site or structure and describe any major alterations from its original condition:

The lack of ornamentation reveals the powerful forms of this gambrel wood-shingle-roofed Colonial Revival design. The third story dormer, a later addition, is a rare example of an insensitive alteration which perversely enhances and enforces the power of the building's original image. The width of the soffits and the size of the windows recede in size with the weight of the building.

- Locational sketch map (draw and label site and surrounding streets, roads, and prominent landmarks):

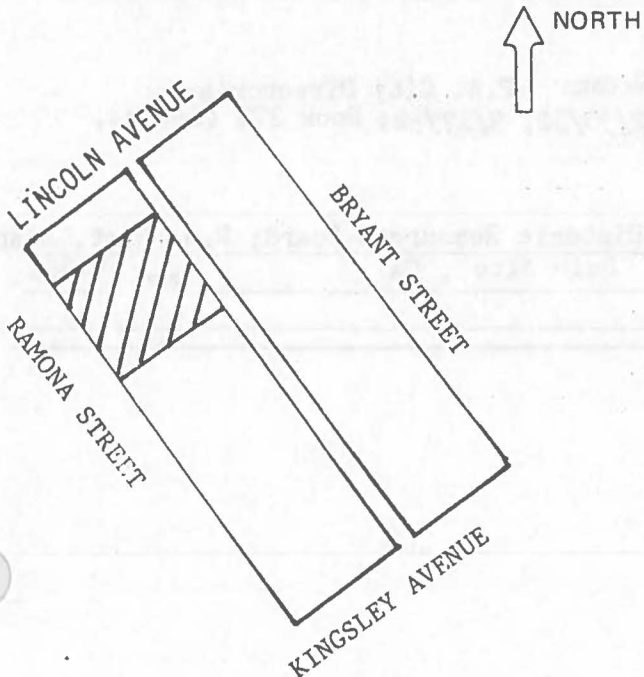

- Approximate property size:  
 Lot size (in feet) Frontage 87.50 ;  
 Depth 105 ;  
 or approx. acreage \_\_\_\_\_.
- Condition: (check one)  
 a. Excellent  b. Good  c. Fair   
 d. Deteriorated  e. No longer in existence
- Is the feature a. Altered?  b. Unaltered?
- Surroundings: (Check more than one if necessary)  
 a. Open land  b. Scattered buildings   
 c. Densely built-up  d. Residential   
 e. Commercial  f. Industrial   
 g. Other  \_\_\_\_\_
- Threats to site:  
 a. None known  b. Private development   
 c. Zoning  d. Public Works project   
 e. Vandalism  f. Other  \_\_\_\_\_

1115 Ramona

NOTE: The following (Items 14-19) are for structures only.

14. Primary exterior building material: a. Stone  b. Brick  c. Stucco  d. Adobe  e. Wood   
f. Other
15. Is the structure: a. On its original site?  b. Moved?  c. Unknown?
16. Year of initial construction 1903 This date is: a. Factual  b. Estimated
17. Architect (if known): \_\_\_\_\_
18. Builder (if known): Gustav Laumeister
19. Related features: a. Barn  b. Carriage house  c. Outhouse  d. Shed(s)  e. Formal garden(s)   
f. Windmill  g. Watertower/tankhouse  h. Other  i. None

SIGNIFICANCE

20. Briefly state historical and/or architectural importance (include dates, events, and persons associated with the site when known):

A powerful image and a good example of the style, this building is also a component of a fine block face.

The first residents were "two Stanford professors, Edwin and Chloe Starks. He was a zoologist, specifically an ichthyologist, as was Stanford's president, Dr. Jordan. Mrs. Starks illustrated the works of both men. Their redwood-paneled study and art studio are still intact on the second floor." (...Gone Tomorrow?) From 1959 to 1984 it was the home of William A. and Joan Wallace; Wallace was supervisor of administrative services at Stanford University.

21. Main theme of the historic resource: (Check only one): a. Architecture  b. Arts & Leisure   
c. Economic/Industrial  d. Exploration/Settlement  e. Government  f. Military   
g. Religion  h. Social/Education
22. Sources: List books, documents, surveys, personal interviews, and their dates: P.A. City Directories; AAUW, ...Gone Tomorrow? ; P.A. Times 1/1/04, 12/30/32, 3/17/52; Book 272 (Deeds), p. 461, 12/5/03 (Santa Clara Co. Recorder)
23. Date form prepared: 1981, 1985 By (name): Lydia Moran; Historic Resources Board; P.A. Hist. Assn.  
Address: 250 Hamilton Ave City Palo Alto, Ca ZIP: 94301  
Phone: \_\_\_\_\_ Organization: \_\_\_\_\_

(State Use Only)

HISTORIC RESOURCES INVENTORY

(State use only)

UTM \_\_\_\_\_ Q \_\_\_\_\_ NR \_\_\_\_\_ SHL \_\_\_\_\_

Lat \_\_\_\_\_ Lon \_\_\_\_\_ Era \_\_\_\_\_ Sig \_\_\_\_\_

Adm \_\_\_\_\_ T2 \_\_\_\_\_ T3 \_\_\_\_\_ Cat \_\_\_\_\_ HABS \_\_\_\_\_ HAER \_\_\_\_\_ Fed \_\_\_\_\_

IDENTIFICATION **Cat. II**

1. Common name: \_\_\_\_\_
2. Historic name, if known: \_\_\_\_\_
3. Street or rural address 1139 Ramona Street (Professorville Historic District)  
City: Palo Alto ZIP: \_\_\_\_\_ County: Santa Clara
4. Present owner, if known: Richard L. and Ruth Dearborn Address: Same  
City: \_\_\_\_\_ ZIP: \_\_\_\_\_ Ownership is: Public  Private
5. Present Use: Residential Original Use: Residential  
Other past uses: \_\_\_\_\_

DESCRIPTION

6. Briefly describe the present physical appearance of the site or structure and describe any major alterations from its original condition:

This is a modest, homey variation of the gambrel, Colonial Revival motif of the 1100 block of Ramona. Chamfered posts support the overhang creating the entry porch.

7. Locational sketch map (draw and label site and surrounding streets, roads, and prominent landmarks):

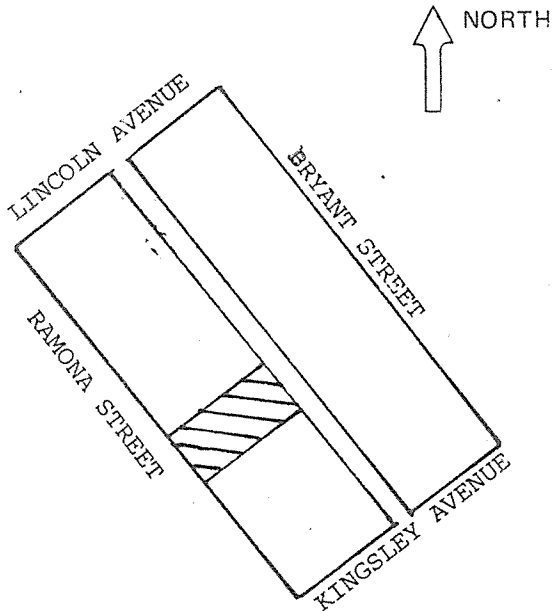

8. Approximate property size:

Lot size (in feet) Frontage 50'  
Depth 105'  
or approx. acreage \_\_\_\_\_

9. Condition: (check one)

a. Excellent  b. Good  c. Fair   
d. Deteriorated  e. No longer in existence

10. Is the feature a. Altered?  b. Unaltered?

11. Surroundings: (Check more than one if necessary)

a. Open land  b. Scattered buildings   
c. Densely built-up  d. Residential   
e. Commercial  f. Industrial   
g. Other  \_\_\_\_\_

12. Threats to site:

a. None known  b. Private development   
c. Zoning  d. Public Works project   
e. Vandalism  f. Other  \_\_\_\_\_

13. Date(s) of enclosed photograph(s): 1978

NOTE: The following (Items 14-19) are for structures only.

14. Primary exterior building material: a. Stone  b. Brick  c. Stucco  d. Adobe  e. Wood   
 f. Other  \_\_\_\_\_
15. Is the structure: a. On its original site?  b. Moved?  c. Unknown?
16. Year of initial construction 1903 This date is: a. Factual  b. Estimated
17. Architect (if known): \_\_\_\_\_
18. Builder (if known): Gus Laumeister
19. Related features: a. Barn  b. Carriage house  c. Outhouse  d. Shed(s)  e. Formal garden(s)   
 f. Windmill  g. Watertower/tankhouse  h. Other  \_\_\_\_\_ i. None

SIGNIFICANCE

20. Briefly state historical and/or architectural importance (include dates, events, and persons associated with the site when known):

This is an unpretentious but rather elegant design and a member of a remarkably consistent block face. Mrs. G.A. Fleming and her daughters were its first occupants, succeeded in the early years by, among others, William C. and Olive Corbett (1910-1919), one of whose sons was born in the house; Mrs. Susan C. Carpenter (1920-1925), Mrs. Nellie Neel (1928-1935), Walter A. and Marie Neller (1936-1943), Mrs. Kathleen Faw (1944-1953), and Dr. and Mrs. Oliver M. Henderson (1956-1970), and Mr. and Mrs. Richard Dearborn (1971-1986).

21. Main theme of the historic resource: (Check only one): a. Architecture  b. Arts & Leisure   
 c. Economic/Industrial  d. Exploration/Settlement  e. Government  f. Military   
 g. Religion  h. Social/Education

22. Sources: List books, documents, surveys, personal interviews, and their dates:

P.A. City Directories ; Book 266 (Deeds), p. 580, 11/9/03 (Santa Clara Co. Recorder)  
 P.A. Times - 12/31/04, 4/2/38, 1/24/55  
 Interview 1981 with Ruth Dearborn

23. Date form prepared: 1981, 1985 (name): Historic Resources Board; P.A. Hist Assn.  
 Address: 250 Hamilton Ave City Palo Alto, Ca 94301 ZIP: \_\_\_\_\_  
 Phone: \_\_\_\_\_ Organization: \_\_\_\_\_

**HISTORIC RESOURCES INVENTORY**

(State use only)  
 Ser \_\_\_\_\_ Site \_\_\_\_\_ Mo. \_\_\_\_\_ Yr. \_\_\_\_\_  
 UTM \_\_\_\_\_ Q \_\_\_\_\_ NR \_\_\_\_\_ SHL \_\_\_\_\_  
 Lat \_\_\_\_\_ Lon \_\_\_\_\_ Era \_\_\_\_\_ Sig \_\_\_\_\_  
 Adm \_\_\_\_\_ T2 \_\_\_\_\_ T3 \_\_\_\_\_ Cat \_\_\_\_\_ HABS \_\_\_\_\_ HAER \_\_\_\_\_ Fed \_\_\_\_\_

**IDENTIFICATION Cat. IV**

1. Common name: \_\_\_\_\_
2. Historic name, if known: \_\_\_\_\_
3. Street or rural address 272 Rinconada Avenue  
 City: Palo Alto ZIP: \_\_\_\_\_ County: Santa Clara
4. Present owner, if known: Catherine Whittmore Address: Same  
 City: \_\_\_\_\_ ZIP: \_\_\_\_\_ Ownership is: Public  Private
5. Present Use: Residential Original Use: Residential  
 Other past uses: \_\_\_\_\_

**DESCRIPTION**

6. Briefly describe the present physical appearance of the site or structure and describe any major alterations from its original condition:

A small Spanish Colonial Revival house with one window in the blank wall facing the street. The building exhibits careful scaling to create a strong visual impact.

7. Locational sketch map (draw and label site and surrounding streets, roads, and prominent landmarks):

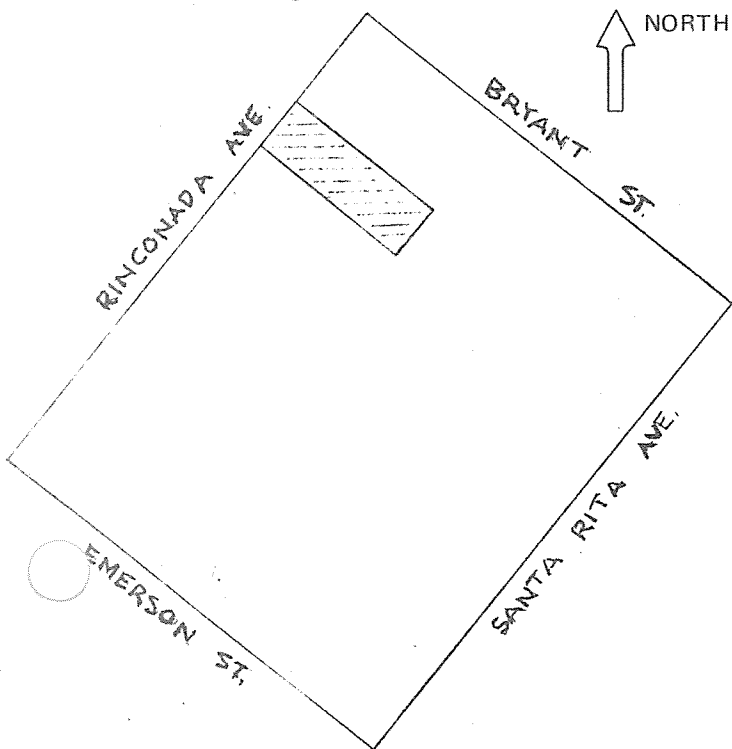

8. Approximate property size:  
 Lot size (in feet) Frontage 50  
 Depth 150;  
 or approx. acreage \_\_\_\_\_
9. Condition: (check one)  
 a. Excellent  b. Good  c. Fair   
 d. Deteriorated  e. No longer in existence
10. Is the feature a. Altered?  b. Unaltered?
11. Surroundings: (Check more than one if necessary)  
 a. Open land  b. Scattered buildings   
 c. Densely built-up  d. Residential   
 e. Commercial  f. Industrial   
 g. Other
12. Threats to site:  
 a. None known  b. Private development   
 c. Zoning  d. Public Works project   
 e. Vandalism  f. Other
13. Date(s) of enclosed photograph(s): 1978



NOTE: The following (Items 14-19) are for structures only.

14. Primary exterior building material: a. Stone  b. Brick  c. Stucco  d. Adobe  e. Wood   
 f. Other  \_\_\_\_\_
15. Is the structure: a. On its original site?  b. Moved?  c. Unknown?
16. Year of initial construction 1931 This date is: a. Factual  b. Estimated
17. Architect (if known): Marcus Stedman
18. Builder (if known): Marcus Stedman (owner and builder)
19. Related features: a. Barn  b. Carriage house  c. Outhouse  d. Shed(s)  e. Formal garden(s)   
 f. Windmill  g. Watertower/tankhouse  h. Other  \_\_\_\_\_ i. None

## SIGNIFICANCE

20. Briefly state historical and/or architectural importance (include dates, events, and persons associated with the site when known):

The house is a skillfully-designed example of Spanish Colonial Revival styling, produced by one of the city's outstanding builders, Douglas M. and Catherine Whittemore. occupied the house in 1932 and there have been no other owners. Whittemore was on the faculties of Menlo College and San Jose City College, and also worked in the 'forties in the Palo Alto main post office.

21. Main theme of the historic resource: (Check only one): a. Architecture  b. Arts & Leisure   
 c. Economic/Industrial  d. Exploration/Settlement  e. Government  f. Military   
 g. Religion  h. Social/Education
22. Sources: List books, documents, surveys, personal interviews, and their dates: P.A. City Directories; P.A. Times 8/13/31, 12/29/69; interview 1985, Catherine Whittemore

23. Date form prepared: 1978, 1985 By (name): Historic Resources Board; P.A. Hist. Assn.  
 Address: Palo Alto, Ca 94301 City \_\_\_\_\_ ZIP: \_\_\_\_\_  
 Phone: \_\_\_\_\_ Organization: \_\_\_\_\_

(State Use Only)

HISTORIC RESOURCES INVENTORY

(State use only)  
 Ser \_\_\_\_\_ Site \_\_\_\_\_ Mo. \_\_\_\_\_ Yr. \_\_\_\_\_  
 UTM \_\_\_\_\_ Q \_\_\_\_\_ NR \_\_\_\_\_ SHL \_\_\_\_\_  
 Lat \_\_\_\_\_ Lon \_\_\_\_\_ Era \_\_\_\_\_ Sig \_\_\_\_\_  
 Adm \_\_\_\_\_ T2 \_\_\_\_\_ T3 \_\_\_\_\_ Cat \_\_\_\_\_ HABS \_\_\_\_\_ HAER \_\_\_\_\_ Fed \_\_\_\_\_

IDENTIFICATION Cat. IV

- Common name: \_\_\_\_\_
- Historic name, if known: \_\_\_\_\_
- Street or rural address 466 Ruthven Avenue  
 City: Palo Alto ZIP: \_\_\_\_\_ County: Santa Clara
- Present owner, if known: Anthony and Katrina Schelich Address: Same  
 City: \_\_\_\_\_ ZIP: \_\_\_\_\_ Ownership is: Public  Private
- Present Use: Residential Original Use: Residential  
 Other past uses: \_\_\_\_\_

DESCRIPTION

- Briefly describe the present physical appearance of the site or structure and describe any major alterations from its original condition:

This small house is saved from mediocrity by overscaled Palladian windows and the fish-scale shingles in the gable, the generously-sized bay, and the Tuscan porch columns.

- Locational sketch map (draw and label site and surrounding streets, roads, and prominent landmarks):

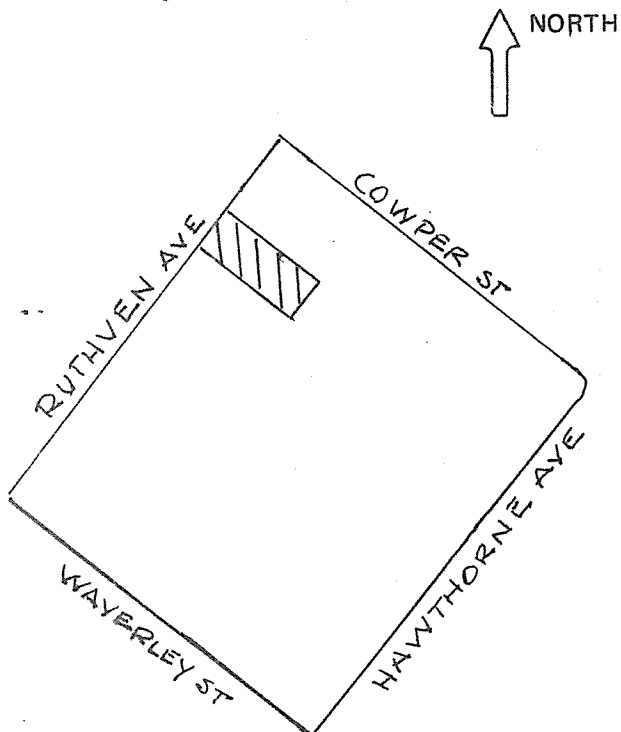

- Approximate property size:  
 Lot size (in feet) Frontage 50  
 Depth 140;  
 or approx. acreage \_\_\_\_\_.
- Condition: (check one)  
 a. Excellent  b. Good  c. Fair   
 d. Deteriorated  e. No longer in existence
- Is the feature a. Altered?  b. Unaltered?
- Surroundings: (Check more than one if necessary)  
 a. Open land  b. Scattered buildings   
 c. Densely built-up  d. Residential   
 e. Commercial  f. Industrial   
 g. Other
- Threats to site:  
 a. None known  b. Private development   
 c. Zoning  d. Public Works project   
 e. Vandalism  f. Other
- Date(s) of enclosed photograph(s): 1978

NOTE: The following (Items 14-19) are for structures only.

14. Primary exterior building material: a. Stone  b. Brick  c. Stucco  d. Adobe  e. Wood   
 f. Other  \_\_\_\_\_
15. Is the structure: a. On its original site?  b. Moved?  c. Unknown?
16. Year of initial construction 1907 This date is: a. Factual  b. Estimated
17. Architect (if known): \_\_\_\_\_
18. Builder (if known): Mark Lucas (owner and builder)
19. Related features: a. Barn  b. Carriage house  c. Outhouse  d. Shed(s)  e. Formal garden(s)   
 f. Windmill  g. Watertower/tankhouse  h. Other  \_\_\_\_\_ i. None

SIGNIFICANCE

20. Briefly state historical and/or architectural importance (include dates, events, and persons associated with the site when known):

The house is a good example of the effects of strongly-emphasized architectural detail on an otherwise plain and small structure. Short-term occupants, beginning with J.D. Patterson, are listed in the house throughout most of its history--an electrician, a telephone repairman, a carpenter, a gardener, a sales clerk, among others. The longest occupancy was that from 1956 to 1976 by William H. Martin. L.D. McDonald, to whom the builder first sold the house, seems not himself to have occupied it. He was said to be a prominent San Francisco lumberman.

21. Main theme of the historic resource: (Check only one): a. Architecture  b. Arts & Leisure   
 c. Economic/Industrial  d. Exploration/Settlement  e. Government  f. Military   
 g. Religion  h. Social/Education

22. Sources: List books, documents, surveys, personal interviews, and their dates: P.A. City Directories; P.A. Times 4/4/, 8/12/07, 1/3/08, 10/24/45; interview 1985, Katrina Schleich

23. Date form prepared: 1978, 1985 By (name): Historic Resources Board  
 Address: 250 Hamilton Ave City Palo Alto, Ca 94301 ZIP: \_\_\_\_\_  
 Phone: \_\_\_\_\_ Organization: \_\_\_\_\_

(State Use Only)

HISTORIC RESOURCES INVENTORY

IDENTIFICATION Cat. III

(State use only)  
 Ser \_\_\_\_\_ Site \_\_\_\_\_ Mo. \_\_\_\_\_ Yr. \_\_\_\_\_  
 UTM \_\_\_\_\_ Q \_\_\_\_\_ NR \_\_\_\_\_ SHL \_\_\_\_\_  
 Lat \_\_\_\_\_ Lon \_\_\_\_\_ Era \_\_\_\_\_ Sig \_\_\_\_\_  
 Adm \_\_\_\_\_ T2 \_\_\_\_\_ T3 \_\_\_\_\_ Cat \_\_\_\_\_ HABS \_\_\_\_\_ HAER \_\_\_\_\_ Fed \_\_\_\_\_

- Common name: \_\_\_\_\_
- Historic name, if known: \_\_\_\_\_
- Street or rural address 936-938 Scott Street  
 City: Palo Alto ZIP: \_\_\_\_\_ County: Santa Clara
- Present owner, if known: Timothy D. Trailer Address: PO Box 428  
 City: Palo Alto, Calif ZIP: 94302 Ownership is: Public  Private
- Present Use: Residential (duplex) Original Use: Residential (single-family)  
 Other past uses: \_\_\_\_\_

DESCRIPTION

- Briefly describe the present physical appearance of the site or structure and describe any major alterations from its original condition:

This Queen Anne residence is a two-story wood frame structure with a decorative porch containing fanciful woodwork of the late Victorian era. The two-story bay with fish scale shingles dramatizes the emphatically vertical design of the building. Decorative ornamentation crowns the two staggered stair windows and animates the facade.

- Locational sketch map (draw and label site and surrounding streets, roads, and prominent landmarks):

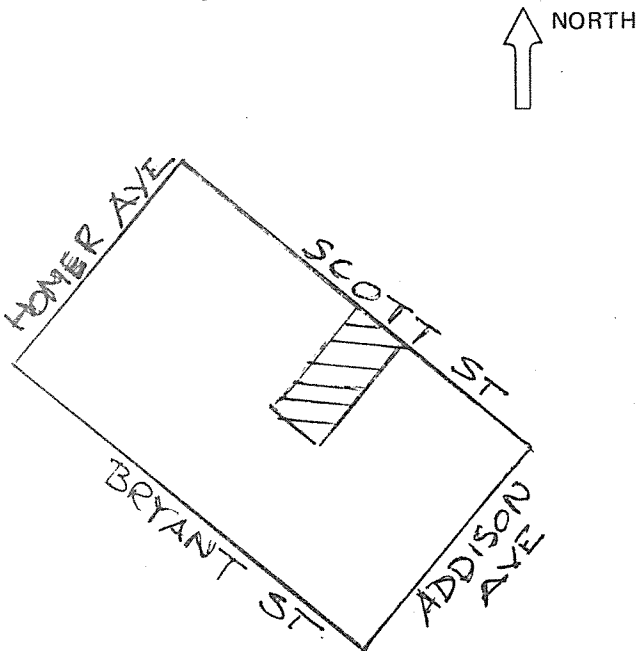

- Approximate property size:  
 Lot size (in feet) Frontage 50  
 Depth 112.5  
 or approx. acreage \_\_\_\_\_
- Condition: (check one)  
 a. Excellent  b. Good  c. Fair   
 d. Deteriorated  e. No longer in existence
- Is the feature a. Altered?  b. Unaltered?   
 1903
- Surroundings: (Check more than one if necessary)  
 a. Open land  b. Scattered buildings   
 c. Densely built-up  d. Residential   
 e. Commercial  f. Industrial   
 g. Other
- Threats to site:  
 a. None known  b. Private development   
 c. Zoning  d. Public Works project   
 e. Vandalism  f. Other

13. Date(s) of enclosed photograph(s): 1978

NOTE: The following (Items 14-19) are for structures only.

14. Primary exterior building material: a. Stone  b. Brick  c. Stucco  d. Adobe  e. Wood   
 f. Other  \_\_\_\_\_
15. Is the structure: a. On its original site?  b. Moved?  c. Unknown?
16. Year of initial construction 1895 This date is: a. Factual  b. Estimated
17. Architect (if known): H.L. Upham
18. Builder (if known): (P.P.) Quinn and (H.L.) Upham; Upham, 1903
19. Related features: a. Barn  b. Carriage house  c. Outhouse  d. Shed(s)  e. Formal garden(s)   
 f. Windmill  g. Watertower/tankhouse  h. Other  \_\_\_\_\_ i. None

SIGNIFICANCE

20. Briefly state historical and/or architectural importance (include dates, events, and persons associated with the site when known):

A modest but unusual and inventive version of the Queen Anne style, originally occupied by E.L. Greenleaf until 1918, then, 1919-1945, by Mr. and Mrs. Marvin M. Sorrells. Sorrells was a painting contractor (living next door, incidentally, to James Stroner, the city's first painter, painting contractor, and paint merchant). In the mid-50s the house was divided into a duplex.

21. Main theme of the historic resource: (Check only one): a. Architecture  b. Arts & Leisure   
 c. Economic/Industrial  d. Exploration/Settlement  e. Government  f. Military   
 g. Religion  h. Social/Education

22. Sources: List books, documents, surveys, personal interviews, and their dates: P.A. City Directories; P.A. Times 3/22 and 5/17/95, 1/2/96, 9/11/03, 4/1/39, 6/2/44

23. Date form prepared: 1978, 1984 By (name): Historic Resources Board  
 Address: 250 Hamilton Ave City Palo Alto, Ca 94301 ZIP: \_\_\_\_\_  
 Phone: \_\_\_\_\_ Organization: \_\_\_\_\_

(State Use Only)

HISTORIC RESOURCES INVENTORY

(State use only)  
 Ser \_\_\_\_\_ Site \_\_\_\_\_ Mo. \_\_\_\_\_ Yr. \_\_\_\_\_  
 UTM \_\_\_\_\_ Q \_\_\_\_\_ NR \_\_\_\_\_ SHL \_\_\_\_\_  
 Lat \_\_\_\_\_ Lon \_\_\_\_\_ Era \_\_\_\_\_ Sig \_\_\_\_\_  
 Adm \_\_\_\_\_ T2 \_\_\_\_\_ T3 \_\_\_\_\_ Cat \_\_\_\_\_ HABS \_\_\_\_\_ HAER \_\_\_\_\_ Fed \_\_\_\_\_

IDENTIFICATION Cat. II

- Common name: \_\_\_\_\_
- Historic name, if known: Dayan Residence
- Street or rural address 449 Seneca (also listed as 909 University)  
 City: Palo Alto ZIP: \_\_\_\_\_ County: Santa Clara
- Present owner, if known: Allen A. and Karen Connel Address: 1952 Menalto Ave  
 City: Menlo Park, Calif ZIP: 94025 Ownership is: Public  Private
- Present Use: Residential Original Use: Residential  
 Other past uses: \_\_\_\_\_

DESCRIPTION

- Briefly describe the present physical appearance of the site or structure and describe any major alterations from its original condition:

This four-square Georgian Revival house was originally set in extensive landscaped grounds and was entered from University Avenue. The delicate carved ornamentation is standard for buildings of the type, but there are deviations from expected form in some window shapes and the rear porch. Under the wide bracketed eaves is a decorative frieze, which is repeated above the windows. The main entrance, now on the side, has a columned portico and opens into an extravagantly large reception hall. The interior echos the classical style. The one-story wing to the left of the entry is a later addition.

- Locational sketch map (draw and label site and surrounding streets, roads, and prominent landmarks):

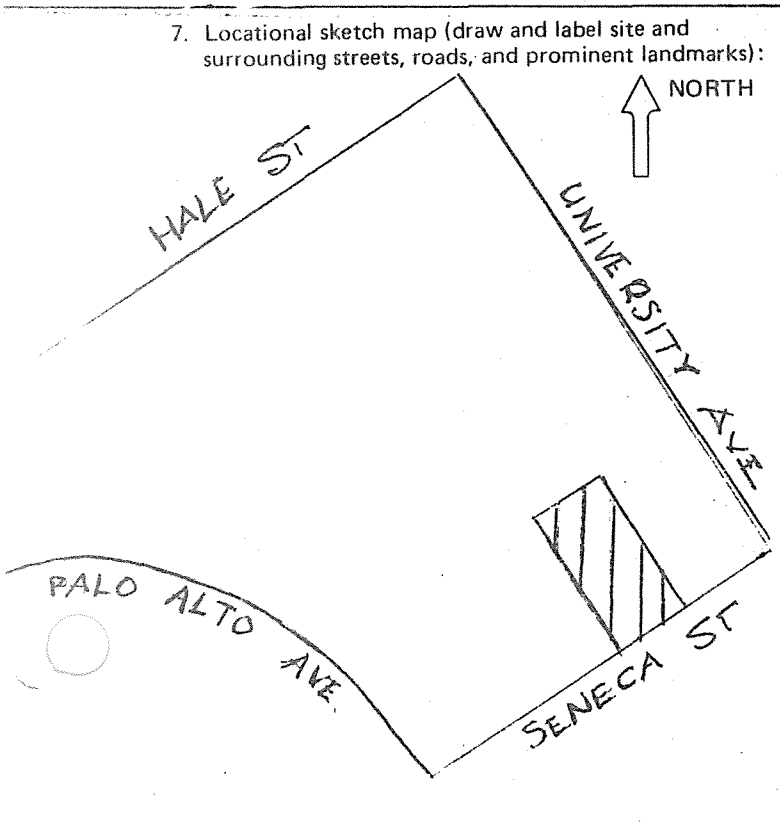

- Approximate property size:  
 Lot size (in feet) Frontage 66  
 Depth 145;  
 or approx. acreage \_\_\_\_\_
- Condition: (check one)  
 a. Excellent  b. Good  c. Fair   
 d. Deteriorated  e. No longer in existence
- Is the feature a. Altered?  b. Unaltered?
- Surroundings: (Check more than one if necessary)  
 a. Open land  b. Scattered buildings   
 c. Densely built-up  d. Residential   
 e. Commercial  f. Industrial   
 g. Other
- Threats to site:  
 a. None known  b. Private development   
 c. Zoning  d. Public Works project   
 e. Vandalism  f. Other

- Date(s) of enclosed photograph(s): 1978

NOTE: The following (Items 14-19) are for structures only.

14. Primary exterior building material: a. Stone  b. Brick  c. Stucco  d. Adobe  e. Wood   
 f. Other  \_\_\_\_\_
15. Is the structure: a. On its original site?  b. Moved?  c. Unknown?
16. Year of initial construction 1895 This date is: a. Factual  b. Estimated
17. Architect (if known): \_\_\_\_\_
18. Builder (if known): William Campbell
19. Related features: a. Barn  b. Carriage house  c. Outhouse  d. Shed(s)  e. Formal garden(s)   
 f. Windmill  g. Watertower/tankhouse  h. Other  \_\_\_\_\_ i. None

## SIGNIFICANCE

20. Briefly state historical and/or architectural importance (include dates, events, and persons associated with the site when known):

The house is an excellent example of the formality and dignity of the Georgian Revival, one of the first in Palo Alto executed in one of the several styles which were about to replace the Queen Anne and comparable Victorian types. It originally had a sweeping lawn and palm-lined drive. J.A. and Mrs. Dyan were the first owners. He was an officer of the Southern Pacific Railroad; she participated vigorously in the development of the new town, taking charge of the landscaping of University Avenue and Alma Street, while he arranged for graveling the streets. From 1916, when the Dayans left the house, to 1953, it was owned by Mrs. Frances E. Corey, and from 1955 to 1969, by Russel J. and Katherine M. Sheridan. Sheridan was an engineer with Pacific Telephone.

21. Main theme of the historic resource: (Check only one): a. Architecture  b. Arts & Leisure   
 c. Economic/Industrial  d. Exploration/Settlement  e. Government  f. Military   
 g. Religion  h. Social/Education
22. Sources: List books, documents, surveys, personal interviews, and their dates: P. A. City Directories; P.A. Times 6/19 and 28/95, 7/12 and 19/95, 10/4/95, 1/2/96; ...Gone Tomorrow?, p. 18-19.
23. Date form prepared: 1978, 1984 By (name): Historic Resources Board  
 Address: 250 Hamilton Ave City Palo Alto, Ca 94301 ZIP: \_\_\_\_\_  
 Phone: \_\_\_\_\_ Organization: \_\_\_\_\_

(State Use Only)

**HISTORIC RESOURCES INVENTORY**

(State use only)  
 Ser \_\_\_\_\_ Site \_\_\_\_\_ Mo. \_\_\_\_\_ Yr. \_\_\_\_\_  
 UTM \_\_\_\_\_ Q \_\_\_\_\_ NR \_\_\_\_\_ SHL \_\_\_\_\_  
 Lat \_\_\_\_\_ Lon \_\_\_\_\_ Era \_\_\_\_\_ Sig \_\_\_\_\_  
 Adm \_\_\_\_\_ T2 \_\_\_\_\_ T3 \_\_\_\_\_ Cat \_\_\_\_\_ HABS \_\_\_\_\_ HAER \_\_\_\_\_ Fed \_\_\_\_\_

**IDENTIFICATION Cat. III**

1. Common name: \_\_\_\_\_
2. Historic name, if known: \_\_\_\_\_
3. Street or rural address 734 Seneca Street  
 City: Palo Alto ZIP: \_\_\_\_\_ County: Santa Clara
4. Present owner, if known: Barbara and Gerry Lapid Address: Same  
 City: \_\_\_\_\_ ZIP: \_\_\_\_\_ Ownership is: Public  Private
5. Present Use: Residential Original Use: Residential  
 Other past uses: \_\_\_\_\_

**DESCRIPTION**

Briefly describe the present physical appearance of the site or structure and describe any major alterations from its original condition:

**This small Classical Revival residence presents a facade which is at once severely formal yet unexpectedly asymmetrical. The semi-circular, columned entrance and the high conservatory wing at the left end are particularly interesting features.**

7. Locational sketch map (draw and label site and surrounding streets, roads, and prominent landmarks):

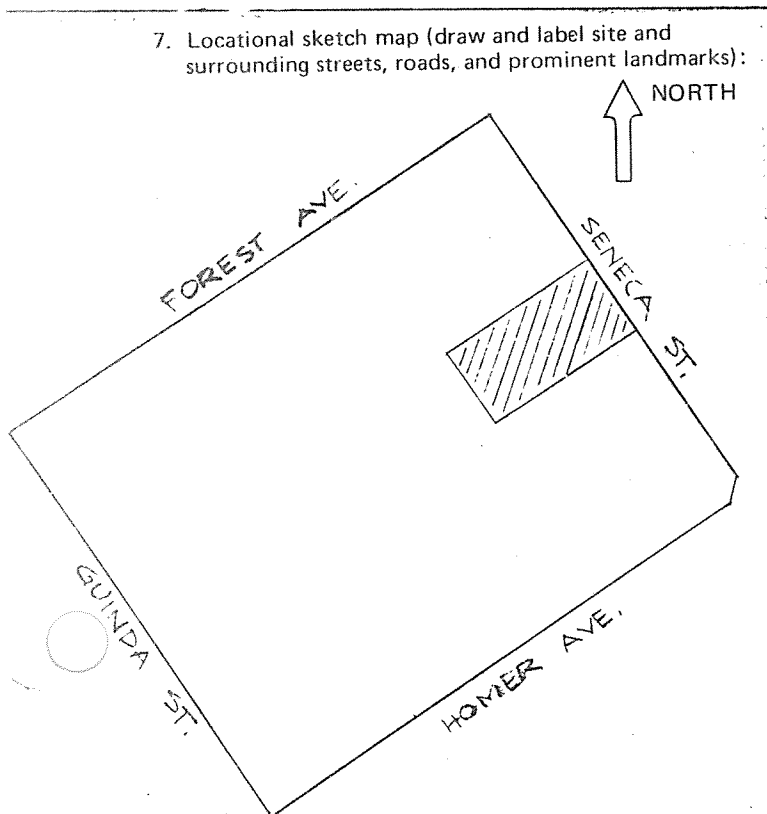

8. Approximate property size:  
 Lot size (in feet) Frontage 77  
 Depth 150  
 or approx. acreage \_\_\_\_\_
9. Condition: (check one)  
 a. Excellent  b. Good  c. Fair   
 d. Deteriorated  e. No longer in existence
10. Is the feature a. Altered?  b. Unaltered?
11. Surroundings: (Check more than one if necessary)  
 a. Open land  b. Scattered buildings   
 c. Densely built-up  d. Residential   
 e. Commercial  f. Industrial   
 g. Other
12. Threats to site:  
 a. None known  b. Private development   
 c. Zoning  d. Public Works project   
 e. Vandalism  f. Other
13. Date(s) of enclosed photograph(s): 1978



NOTE: The following (Items 14-19) are for structures only.

14. Primary exterior building material: a. Stone  b. Brick  c. Stucco  d. Adobe  e. Wood   
 f. Other  \_\_\_\_\_
15. Is the structure: a. On its original site?  b. Moved?  c. Unknown?
16. Year of initial construction 1925 This date is: a. Factual  b. Estimated
17. Architect (if known): \_\_\_\_\_
18. Builder (if known): Joseph Dunn (Berkeley)\*
19. Related features: a. Barn  b. Carriage house  c. Outhouse  d. Shed(s)  e. Formal garden(s)   
 f. Windmill  g. Watertower/tankhouse  h. Other  \_\_\_\_\_ i. None

SIGNIFICANCE

20. Briefly state historical and/or architectural importance (include dates, events, and persons associated with the site when known):  
 An individualistic approach to Classical Revival design creates an important and memorable structure. Gustav Berson, a salesman, first owned it, 1926-33, followed by W.H. Moulthrop, 1936-49. It appears that it was rental property during the 'fifties. Short-term owners since then included Max A. and Robin Martin (1962-6); Edward J. Tearney (1967-73), clothing store owner; and in the later 1970s and early 1980s, Stephen W. Player, attorney; and Donald Rowe, an employee of Hewlett-Packard Co.

21. Main theme of the historic resource: (Check only one): a. Architecture  b. Arts & Leisure   
 c. Economic/Industrial  d. Exploration/Settlement  e. Government  f. Military   
 g. Religion  h. Social/Education

22. Sources: List books, documents, surveys, personal interviews, and their dates: P.A. City Directories; Interviews 1985, Stephen Player, Shirley Hyatt, Irene Dynes, Edward Tearney, Barbara Lapid; P.A. Times 6/17, 6/22, 7/21, 12/16/25, 2/16/34; Book 95 (Off. Records), p. 108, 6/25/24; Book 248 (Off. Records), p. 176, 10/18/27; Book 204 (Off. Records), p. 230, 12/5/25 (Santa Clara Co. Recorder)

23. Date form prepared: 1978, 1985 By (name): Historic Resources Board  
 Address: 250 Hamilton Ave City: Palo Alto, Ca 94301 ZIP: \_\_\_\_\_  
 Phone: \_\_\_\_\_ Organization: \_\_\_\_\_

\* Oakland City Directory 1924 (State Use Only)  
(Contractors)

HISTORIC RESOURCES INVENTORY

(State use only)  
 Ser \_\_\_\_\_ Site \_\_\_\_\_ Mo. \_\_\_\_\_ Yr. \_\_\_\_\_  
 UTM \_\_\_\_\_ Q \_\_\_\_\_ NR \_\_\_\_\_ SHL \_\_\_\_\_  
 Lat \_\_\_\_\_ Lon \_\_\_\_\_ Era \_\_\_\_\_ Sig \_\_\_\_\_  
 Adm \_\_\_\_\_ T2 \_\_\_\_\_ T3 \_\_\_\_\_ Cat \_\_\_\_\_ HABS \_\_\_\_\_ HAER \_\_\_\_\_ Fed \_\_\_\_\_

IDENTIFICATION Dist. IV

- Common name: \_\_\_\_\_
- Historic name, if known: \_\_\_\_\_
- Street or rural address 352 Stanford Avenue  
 City: Palo Alto ZIP: \_\_\_\_\_ County: Santa Clara
- Present owner, if known: John P. and Madeleine B. Slattery Address: Same  
 City: \_\_\_\_\_ ZIP: \_\_\_\_\_ Ownership is: Public  Private
- Present Use: Residence Original Use: Residence  
 Other past uses: \_\_\_\_\_

DESCRIPTION

- Briefly describe the present physical appearance of the site or structure and describe any major alterations from its original condition:

This simple rectangular Colonial Revival house has an elegantly detailed front porch.

- Locational sketch map (draw and label site and surrounding streets, roads, and prominent landmarks):

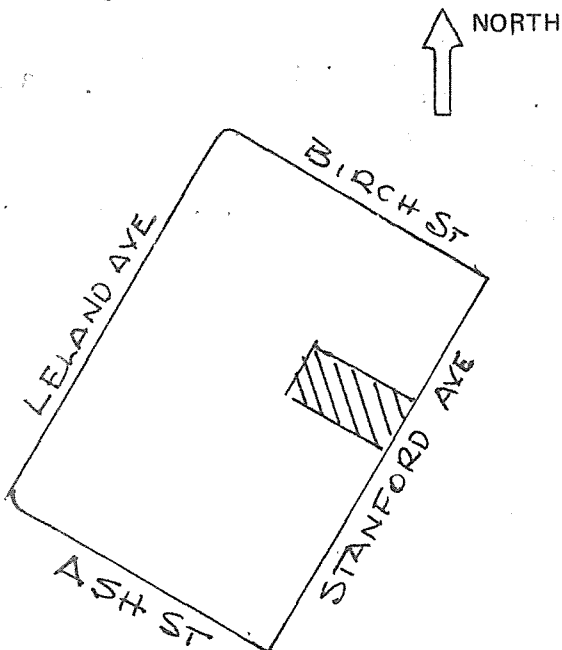

- Approximate property size:  
 Lot size (in feet) Frontage 50  
 Depth 150  
 or approx. acreage \_\_\_\_\_
- Condition: (check one)  
 a. Excellent  b. Good  c. Fair   
 d. Deteriorated  e. No longer in existence
- Is the feature a. Altered?  b. Unaltered?
- Surroundings: (Check more than one if necessary)  
 a. Open land  b. Scattered buildings   
 c. Densely built-up  d. Residential   
 e. Commercial  f. Industrial   
 g. Other
- Threats to site:  
 a. None known  b. Private development   
 c. Zoning  d. Public Works project   
 e. Vandalism  f. Other
- Date(s) of enclosed photograph(s): 1978

352 Stanford

NOTE: The following (Items 14-19) are for structures only.

14. Primary exterior building material: a. Stone  b. Brick  c. Stucco  d. Adobe  e. Wood   
 f. Other  \_\_\_\_\_
15. Is the structure: a. On its original site?  b. Moved?  c. Unknown?
16. Year of initial construction 1906 This date is: a. Factual  b. Estimated
17. Architect (if known): \_\_\_\_\_
18. Builder (if known): Thomas Warrior?
19. Related features: a. Barn  b. Carriage house  c. Outhouse  d. Shed(s)  e. Formal garden(s)   
 f. Windmill  g. Watertower/tankhouse  h. Other  \_\_\_\_\_ i. None

SIGNIFICANCE

20. Briefly state historical and/or architectural importance (include dates, events, and persons associated with the site when known):  
 This is a dignified vernacular interpretation of Colonial Revival style. It was probably built by the first owner, Thomas Warrior, a carpenter. He and his wife Linda occupied it until the mid-1920s. From 1924 until 1939 its owner was Albert J. Hettinger, who engaged in real estate and insurance affairs. During the 1940s it was sometimes rented, sometimes vacant, and it was acquired by the present owners in 1949.

21. Main theme of the historic resource: (Check only one): a. Architecture  b. Arts & Leisure   
 c. Economic/Industrial  d. Exploration/Settlement  e. Government  f. Military   
 g. Religion  h. Social/Education

22. Sources: List books, documents, surveys, personal interviews, and their dates: P.A. City Directories; Mayfield Block Map, ca. 1921, P.A. Hist. Assn. files; Book 319 (Deeds), p. 423-4, 5/20/07 (Santa Clara Co. Recorder); P.A. Times 6/2/06

23. Date form prepared: 1978, 1985 By (name): Historic Resources Board; P.A. Hist. Assn.  
 Address: 250 Hamilton Ave City Palo Alto, Ca 94301 ZIP: \_\_\_\_\_  
 Phone: \_\_\_\_\_ Organization: \_\_\_\_\_

(State Use Only)

--	--

**HISTORIC RESOURCES INVENTORY**

(State use only)  
 Ser \_\_\_\_\_ Site \_\_\_\_\_ Mo. \_\_\_\_\_ Yr. \_\_\_\_\_  
 UTM \_\_\_\_\_ Q \_\_\_\_\_ NR \_\_\_\_\_ SHL \_\_\_\_\_  
 Lat \_\_\_\_\_ Lon \_\_\_\_\_ Era \_\_\_\_\_ Sig \_\_\_\_\_  
 Adm \_\_\_\_\_ T2 \_\_\_\_\_ T3 \_\_\_\_\_ Cat \_\_\_\_\_ HABS \_\_\_\_\_ HAER \_\_\_\_\_ Fed \_\_\_\_\_

**IDENTIFICATION Cat. IV**

1. Common name: \_\_\_\_\_
2. Historic name, if known: \_\_\_\_\_
3. Street or rural address 374 Stanford Avenue  
 City: Palo Alto ZIP: \_\_\_\_\_ County: Santa Clara
4. Present owner, if known: Mrs. Margaret L. Slowik Address: Same  
 City: \_\_\_\_\_ ZIP: \_\_\_\_\_ Ownership is: Public  Private
5. Present Use: Residence Original Use: Residence  
 Other past uses: \_\_\_\_\_

**DESCRIPTION**

6. Briefly describe the present physical appearance of the site or structure and describe any major alterations from its original condition:

**This two-story house is dominated by its gambrel roof, a trademark of the Dutch Colonial Revival mode.**

7. Locational sketch map (draw and label site and surrounding streets, roads, and prominent landmarks):

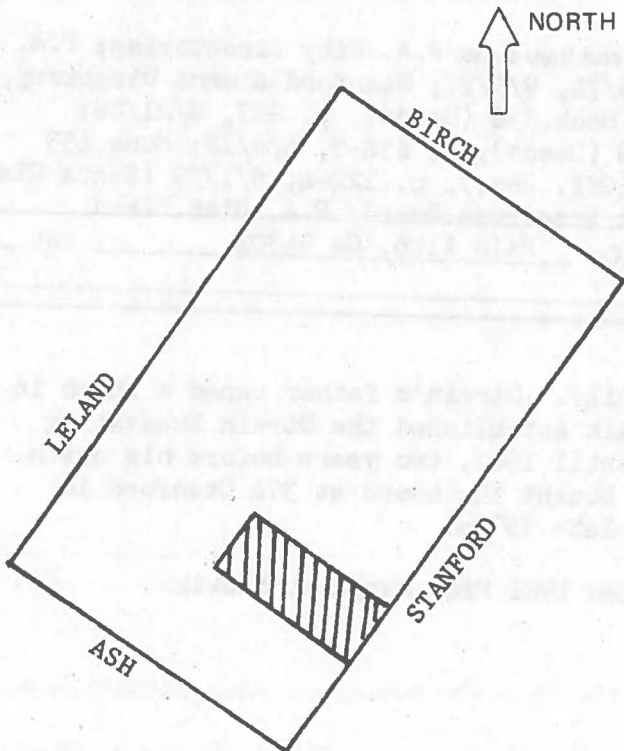

8. Approximate property size:

Lot size (in feet) Frontage 50  
 Depth 150  
 or approx. acreage \_\_\_\_\_

9. Condition: (check one)

- a. Excellent  b. Good  c. Fair   
 d. Deteriorated  e. No longer in existence

10. Is the feature a. Altered?  b. Unaltered?

11. Surroundings: (Check more than one if necessary)

- a. Open land  b. Scattered buildings   
 c. Densely built-up  d. Residential   
 e. Commercial  f. Industrial   
 g. Other

12. Threats to site:

- a. None known  b. Private development   
 c. Zoning  d. Public Works project   
 e. Vandalism  f. Other

13. Date(s) of enclosed photograph(s): 1978

NOTE: The following (Items 14-19) are for structures only.

14. Primary exterior building material: a. Stone  b. Brick  c. Stucco  d. Adobe  e. Wood   
 f. Other
15. Is the structure: a. On its original site?  b. Moved?  c. Unknown?
16. Year of initial construction 1906 This date is: a. Factual  b. Estimated
17. Architect (if known): \_\_\_\_\_
18. Builder (if known): \_\_\_\_\_
19. Related features: a. Barn  b. Carriage house  c. Outhouse  d. Shed(s)  e. Formal garden(s)   
 f. Windmill  g. Watertower/tankhouse  h. Other  i. None

## SIGNIFICANCE

20. Briefly state historical and/or architectural importance (include dates, events, and persons associated with the site when known):

This building is a good example of the Colonial Revival as simplified by the vernacular builder. It was one of the early houses in Evergreen Park, and was built for Eliza H. Yocum, who evidently became

interested in local property while completing her A.B. in English at Stanford (1904). Four years later she sold to Dr. and Mrs. Jonas J. Moyer who, in turn two years later, sold to Dr. J.L. and Frances A. McLaren. The McLarens came from Oakland in 1910 and invested in land in Mayfield and Los Altos. They lived at 374 Stanford only two years until a Los Altos home had been completed. The house was sold in 1912 to Nathan A. and Imogen Moore. Moore was a salesman for the Mayfield Package Co. at the time; later he clerked for Smith's bicycle and sporting goods store in Palo Alto. After the death of his first wife in 1920, he re-married and in 1933 deeded the property to his second wife, Arcadia. Successors \*\*\*

21. Main theme of the historic resource: (Check only one): a. Architecture  b. Arts & Leisure   
 c. Economic/Industrial  d. Exploration/Settlement  e. Government  f. Military   
 g. Religion  h. Social/Education
22. Sources: List books, documents, surveys, personal interviews, and their dates: P.A. City Directories; P.A. Times 6/2/06, 2/10/10, 8/5/10, 12/27/20, 12/5/74, 9/5/77; Stanford Alumni Directory, 1957; Book 308 (Deeds), p. 371-2, 6/6/06; Book 336 (Deeds), p. 227, 8/21/08; Book 351 (Deeds), p. 447, 3/4/10; Book 388 (Deeds), p. 458-9, 6/6/12; Book 653 (Off. Rec.), p. 468-9, 5/27/33; Book 931 (Off. Rec.), p. 122-4, 5/1/39 (Santa Clara \*\*\*)
23. Date form prepared: 1981, 1986 By (name): Historic Resources Board; P.A. Hist. Assn.  
 Address: 250 Hamilton Ave City Palo Alto, Ca 94301 ZIP: \_\_\_\_\_  
 Phone: \_\_\_\_\_ Organization: \_\_\_\_\_

(State Use Only)

\*\*\* to the Moores was the Everett Strain family. Strain's father owned a ranch in what is now Barron Park in the 1920s. Strain established the Strain Excavating and Paving Co. in 1930, which he operated until 1967, two years before his death. Having married Gladys Whitsell in 1938, he bought the house at 374 Stanford in 1939, and it was the Strain home until the late 1970s.

### (Sources cont'd) Co. Recorder; interview 1981 Mrs. Margaret Slowik

**HISTORIC RESOURCES INVENTORY**

(State use only)

Ser \_\_\_\_\_ Site \_\_\_\_\_ Mo. \_\_\_\_\_ Yr. \_\_\_\_\_  
 UTM \_\_\_\_\_ Q \_\_\_\_\_ NR \_\_\_\_\_ SHL \_\_\_\_\_  
 Lat \_\_\_\_\_ Lon \_\_\_\_\_ Era \_\_\_\_\_ Sig \_\_\_\_\_  
 Adm \_\_\_\_\_ T2 \_\_\_\_\_ T3 \_\_\_\_\_ Cat \_\_\_\_\_ HABS \_\_\_\_\_ HAER \_\_\_\_\_ Fed \_\_\_\_\_

**IDENTIFICATION Cat. IV**

1. Common name: \_\_\_\_\_
2. Historic name, if known: \_\_\_\_\_
3. Street or rural address 549 Stanford Avenue  
 City: Palo Alto ZIP: \_\_\_\_\_ County: Santa Clara
4. Present owner, if known: John Olson Address: Same  
 City: \_\_\_\_\_ ZIP: \_\_\_\_\_ Ownership is: Public  Private
5. Present Use: Residence Original Use: Residence  
 Other past uses: \_\_\_\_\_

**DESCRIPTION**

6. Briefly describe the present physical appearance of the site or structure and describe any major alterations from its original condition:

**This two-story Medieval Revival cottage achieves a Hansel and Gretel quality through use of scale devices. The elements of the facade are also composed in a highly skilled fashion**

7. Locational sketch map (draw and label site and surrounding streets, roads, and prominent landmarks):

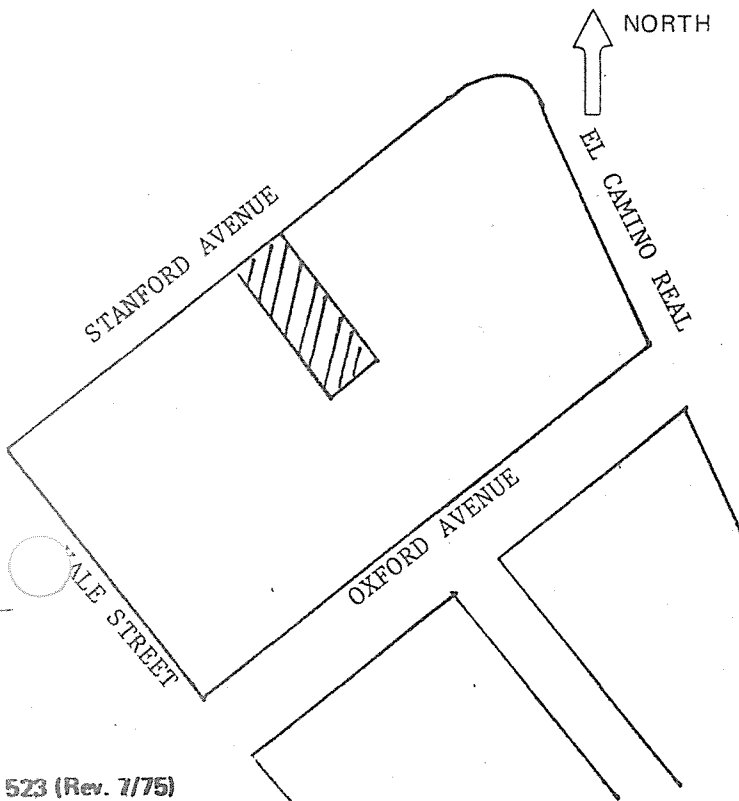

8. Approximate property size:

Lot size (in feet) Frontage 50  
 Depth 115  
 or approx. acreage \_\_\_\_\_

9. Condition: (check one)

a. Excellent  b. Good  c. Fair   
 d. Deteriorated  e. No longer in existence

10. Is the feature a. Altered?  b. Unaltered?

11. Surroundings: (Check more than one if necessary)

a. Open land  b. Scattered buildings   
 c. Densely built-up  d. Residential   
 e. Commercial  f. Industrial   
 g. Other

12. Threats to site:

a. None known  b. Private development   
 c. Zoning  d. Public Works project   
 e. Vandalism  f. Other

13. Date(s) of enclosed photograph(s): 1978

NOTE: The following (Items 14-19) are for structures only.

14. Primary exterior building material: a. Stone  b. Brick  c. Stucco  d. Adobe  e. Wood   
 f. Other  \_\_\_\_\_
15. Is the structure: a. On its original site?  b. Moved?  c. Unknown?
16. Year of initial construction 1926 This date is: a. Factual  b. Estimated
17. Architect (if known): \_\_\_\_\_
18. Builder (if known): George B. Moore (probable)
19. Related features: a. Barn  b. Carriage house  c. Outhouse  d. Shed(s)  e. Formal garden(s)   
 f. Windmill  g. Watertower/tankhouse  h. Other  \_\_\_\_\_ i. None

## SIGNIFICANCE

20. Briefly state historical and/or architectural importance (include dates, events, and persons associated with the site when known):

This building evidences rare skill and care in scale manipulation. Roger and Marjorie Sherman purchased the lot, among other real estate investments, from George B. and Sadie Moore in 1924; the Moores owned the adjoining property. A substantial loan raised on the property in 1926, as well as inferences drawn from City Directory entries suggests the date of construction; the prior owner was himself a well-established Palo Alto and Mayfield builder. Various tenants rented the house after its construction, starting with Elmer R. and Grace Goudy. From 1944-1946, Albert V. and Joan C. Baez (with young daughter Joan) were the owners. Mrs. Roy Sands McCann bought from the Baez family and, in 1949, sold to the Olsons, the present owners.

21. Main theme of the historic resource: (Check only one): a. Architecture  b. Arts & Leisure   
 c. Economic/Industrial  d. Exploration/Settlement  e. Government  f. Military   
 g. Religion  h. Social/Education

22. Sources: List books, documents, surveys, personal interviews, and their dates: P.A. City Directories; Book 65 (Off. Rec.), p. 367-8, 1/16/24; Book 265 (Off. Rec.), p. 334-8, 9/14/26; Book 1187 (Off. Rec.), p. 284-5, 1/13-14/44; Book 1365 (Off. Rec.), p. 570, 7/2/46; Book 1453 (Off. Rec.), p. 352, 1/29/47; Book 1883 (Off. Rec.), p. 326, 11/7/49 (Santa Clara Co. Recorder); interview 1981, John Olson

23. Date form prepared: 1981, 1985 By (name): Historic Resources Board; P.A. Hist. Assn.

Address: 250 Hamilton Ave City Palo Alto, Ca ZIP: 94301

Phone: \_\_\_\_\_ Organization: \_\_\_\_\_

(State Use Only)

HISTORIC RESOURCES INVENTORY

(State use or  
UTM \_\_\_\_\_ Q \_\_\_\_\_ NR \_\_\_\_\_ SHL \_\_\_\_\_  
Lat \_\_\_\_\_ Lon \_\_\_\_\_ Era \_\_\_\_\_ Sig \_\_\_\_\_  
Adm \_\_\_\_\_ T2 \_\_\_\_\_ T3 \_\_\_\_\_ Cat \_\_\_\_\_ HABS \_\_\_\_\_ HAER \_\_\_\_\_ Fed \_\_\_\_\_

NOTIFICATION Cat. IV

1. Common name: Holston Residence (First)
  2. Historic name, if known: \_\_\_\_\_
  3. Street or rural address 591 Stanford Avenue  
City: Palo Alto ZIP: 94306 County: Santa Clara
  4. Present owner, if known: John F. Albrecht Address: Same  
City: \_\_\_\_\_ ZIP: \_\_\_\_\_ Ownership is: Public  Private
  5. Present Use: Residence Original Use: Residence
- Other past uses: \_\_\_\_\_

DESCRIPTION

6. Briefly describe the present physical appearance of the site or structure and describe any major alterations from its original condition:  
The decorative detailing of this one-story house, including brackets, porch columns and window patterns are purely Colonial Revival, but the cantilevered square-corner bay is a common Mission Revival device.  
A portion of the front porch is enclosed and the upstairs has been remodeled into one large bedroom from the original. The bath and kitchen have both been modernized.  
The name "HOLSTON" is stamped into the concrete between curb and sidewalk on the Stanford Avenue side of the house.

7. Locational sketch map (draw and label site and surrounding streets, roads, and prominent landmarks):

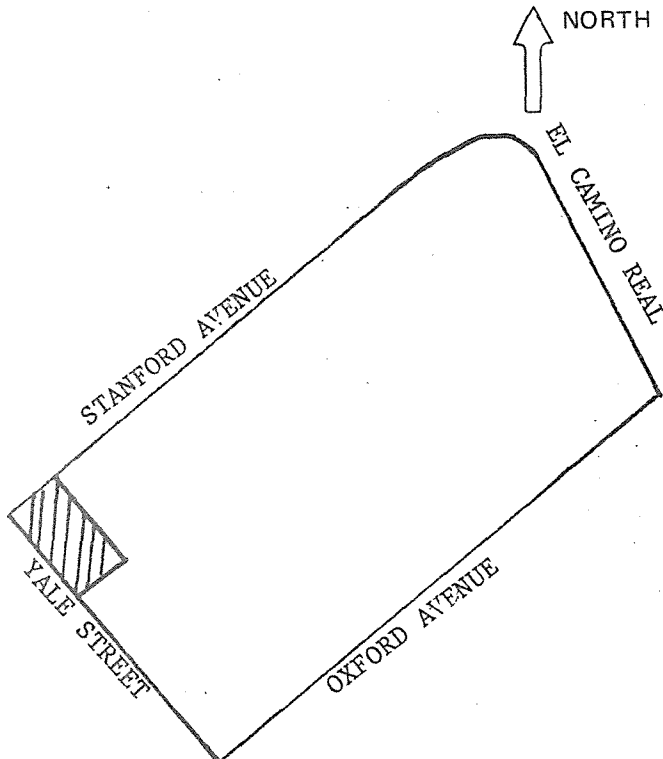

8. Approximate property size:  
Lot size (in feet) Frontage 55  
Depth 87;  
or approx. acreage \_\_\_\_\_.
9. Condition: (check one)  
a. Excellent  b. Good  c. Fair   
d. Deteriorated  e. No longer in existence
10. Is the feature a. Altered?  b. Unaltered?
11. Surroundings: (Check more than one if necessary)  
a. Open land  b. Scattered buildings   
c. Densely built-up  d. Residential   
e. Commercial  f. Industrial   
g. Other  \_\_\_\_\_
12. Threats to site:  
a. None known  b. Private development   
c. Zoning  d. Public Works project   
e. Vandalism  f. Other  \_\_\_\_\_
13. Date(s) of enclosed photograph(s): 1978



NOTE: The following (Items 14-19) are for structures only.

14. Primary exterior building material: a. Stone  b. Brick  c. Stucco  d. Adobe  e. Wood   
 f. Other  \_\_\_\_\_
15. Is the structure: a. On its original site?  b. Moved?  c. Unknown?
16. Year of initial construction 1904 This date is: a. Factual  b. Estimated
17. Architect (if known): \_\_\_\_\_
18. Builder (if known): Ole Olsen
19. Related features: a. Barn  b. Carriage house  c. Outhouse  d. Shed(s)  e. Formal garden(s)   
 f. Windmill  g. Watertower/tankhouse  h. Other  \_\_\_\_\_ i. None

## SIGNIFICANCE

20. Briefly state historical and/or architectural importance (include dates, events, and persons associated with the site when known):

Bert R. Holston and his wife Gussie came to Mayfield in 1904 from Salinas, he to be the Southern Pacific RR agent at the Mayfield Station until his death in 1941. Soon after arriving they contracted for a new house, where they lived until 1921 (then moving to 390 Leland Avenue). Mrs. Holston died at age 65 in 1937. The Holstons were succeeded in the '20s and '30s by James Whitten (1869-1938), a retired rancher, and his wife Agnes. Following the Whittens was Mrs. Leona P. Pearson (1947-1955) and Mai Simpson (1956-62). Donati D' Espiso occupied it from 1963-1969, succeeded by a number of short-term occupants until the mid-70s.

21. Main theme of the historic resource: (Check only one): a. Architecture  b. Arts & Leisure   
 c. Economic/Industrial  d. Exploration/Settlement  e. Government  f. Military   
 g. Religion  h. Social/Education
22. Sources: List books, documents, surveys, personal interviews, and their dates:  
 Personal knowledge of lifetime resident Lillian L. Kirkbride  
 P.A. City Directories \_\_\_\_\_ California Home August 1904  
 P.A. Historical Assn. Files \_\_\_\_\_ Interview July 1981 with John Albrecht  
 P.A. Times 9/14/04, 4/25/33, 6/3/47
23. Date form prepared: 1981, 1985 By (name): Historic Resources Board; P.A. Hist. Assn.  
 Address: 250 Hamilton Ave City Palo Alto, Ca 94301 ZIP: \_\_\_\_\_  
 Phone: \_\_\_\_\_ Organization: \_\_\_\_\_

(State Use Only)

HISTORIC RESOURCES INVENTORY

(State use only)

UTM \_\_\_\_\_ U \_\_\_\_\_

Lat \_\_\_\_\_ Lon \_\_\_\_\_ Era \_\_\_\_\_ Sig \_\_\_\_\_

Adm \_\_\_\_\_ T2 \_\_\_\_\_ T3 \_\_\_\_\_ Cat \_\_\_\_\_ HABS \_\_\_\_\_ HAER \_\_\_\_\_ Fed \_\_\_\_\_

IDENTIFICATION Cat. IV

- Common name: \_\_\_\_\_
  - Historic name, if known: Mc Innis House
  - Street or rural address: 613 Stanford Avenue  
 City: Palo Alto ZIP: \_\_\_\_\_ County: Santa Clara
  - Present owner, if known: Margaret Patton Address: Same  
 City: \_\_\_\_\_ ZIP: \_\_\_\_\_ Ownership is: Public  Private
  - Present Use: Residential Original Use: Residential
- Other past uses: \_\_\_\_\_

DESCRIPTION

6. Briefly describe the present physical appearance of the site or structure and describe any major alterations from its original condition:

This small one-story vernacular house with a pyramidal roof form has been enriched by a porch of considerable delicacy.

7. Locational sketch map (draw and label site and surrounding streets, roads, and prominent landmarks):

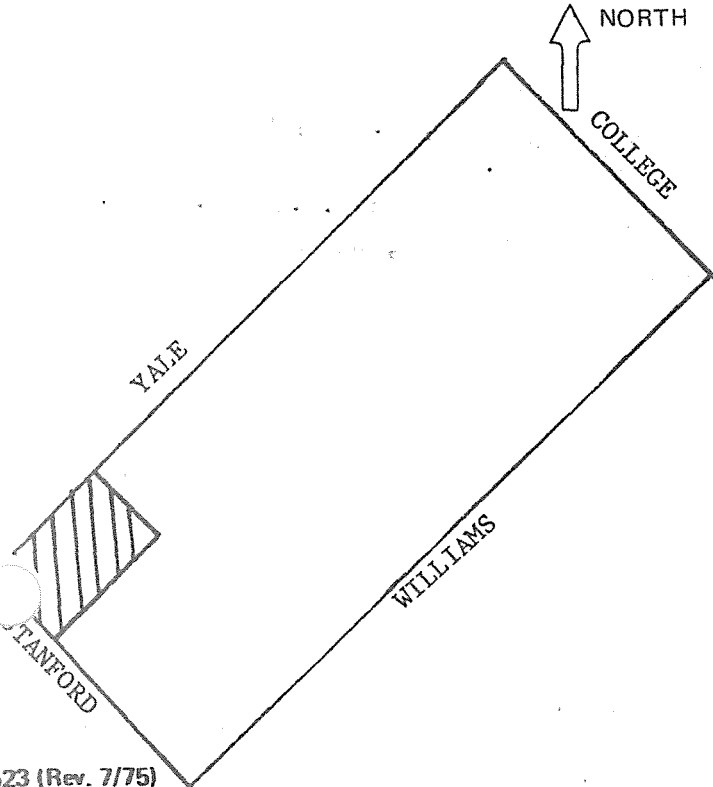

8. Approximate property size:

Lot size (in feet) Frontage 75  
 Depth 125  
 or approx. acreage \_\_\_\_\_

9. Condition: (check one)

- a. Excellent  b. Good  c. Fair   
 d. Deteriorated  e. No longer in existence

10. Is the feature a. Altered?  b. Unaltered?

11. Surroundings: (Check more than one if necessary)

- a. Open land  b. Scattered buildings   
 c. Densely built-up  d. Residential   
 e. Commercial  f. Industrial   
 g. Other  \_\_\_\_\_

12. Threats to site:

- a. None known  b. Private development   
 c. Zoning  d. Public Works project   
 e. Vandalism  f. Other  \_\_\_\_\_

13. Date(s) of enclosed photograph(s): 1978

NOTE: The following (Items 14-19) are for structures only.

14. Primary exterior building material: a. Stone  b. Brick  c. Stucco  d. Adobe  e. Wood   
 f. Other  \_\_\_\_\_
15. Is the structure: a. On its original site?  b. Moved?  c. Unknown?
16. Year of initial construction 1899 This date is: a. Factual  b. Estimated
17. Architect (if known): \_\_\_\_\_
18. Builder (if known): \_\_\_\_\_
19. Related features: a. Barn  b. Carriage house  c. Outhouse  d. Shed(s)  e. Formal garden(s)   
 f. Windmill  g. Watertower/tankhouse  h. Other  \_\_\_\_\_ i. None

## SIGNIFICANCE

20. Briefly state historical and/or architectural importance (include dates, events, and persons associated with the site when known):

A fine example of vernacular building art, this house was owned first by the early Mayfield blacksmiths and wagon makers W.C. and Peter McInnis. The latter worked worked in the Stanford Buildings and Grounds department and lived in the house until 1940. His wife, Addie, died in 1929; he, in 1956. From 1940 to 1974, the house belonged to Melvin A. and Bernice Nelson. Nelson was an employee of the Stanford Board of Athletic Control. Since 1975 it has been the home of the present owner.

21. Main theme of the historic resource: (Check only one): a. Architecture  b. Arts & Leisure   
 c. Economic/Industrial  d. Exploration/Settlement  e. Government  f. Military   
 g. Religion  h. Social/Education

22. Sources: List books, documents, surveys, personal interviews, and their dates:

P.A. Historical Assn. Files California Home, July 1904  
 P.A. City Directories Book 104 (Deeds), p. 355, 6/12/88 Santa  
 P.A. Times 2/16/29, 10/2/56 Clara Co. Recorder

23. Date form prepared: 1981, 1985 By (name): Historic Resources Board; P.A. Hist. Assn.  
 Address: 250 Hamilton Ave City Palo Alto, Ca 94301 ZIP: \_\_\_\_\_  
 Phone: \_\_\_\_\_ Organization: \_\_\_\_\_

(State Use Only)

HISTORIC RESOURCES INVENTORY

(State use only)

Ser \_\_\_\_\_ Site \_\_\_\_\_ Mo. \_\_\_\_\_ Yr. \_\_\_\_\_  
 UTM \_\_\_\_\_ Q \_\_\_\_\_ NR \_\_\_\_\_ SHL \_\_\_\_\_  
 Lat \_\_\_\_\_ Lon \_\_\_\_\_ Era \_\_\_\_\_ Sig \_\_\_\_\_  
 Adm \_\_\_\_\_ T2 \_\_\_\_\_ T3 \_\_\_\_\_ Cat \_\_\_\_\_ HABS \_\_\_\_\_ HAER \_\_\_\_\_ Fed \_\_\_\_\_

IDENTIFICATION Cat. II

- Common name: \_\_\_\_\_
- Historic name, if known: \_\_\_\_\_
- Street or rural address 1215 Stanford Avenue (early address, 811 Stanford Ave.)  
 City: Palo Alto ZIP: \_\_\_\_\_ County: Santa Clara
- Present owner, if known: Richard and Jennifer Mohr Address: Same  
 City: \_\_\_\_\_ ZIP: \_\_\_\_\_ Ownership is: Public  Private
- Present Use: Residence Original Use: Residence  
 Other past uses: \_\_\_\_\_

DESCRIPTION

- Briefly describe the present physical appearance of the site or structure and describe any major alterations from its original condition:

This restrained one-story Queen Anne cottage with its porch, bay window, and bands of patterned shingles shows the vernacular interpretation of a standard nineteenth century form. It is a near twin of 1229 Stanford Avenue.

- Locational sketch map (draw and label site and surrounding streets, roads, and prominent landmarks):

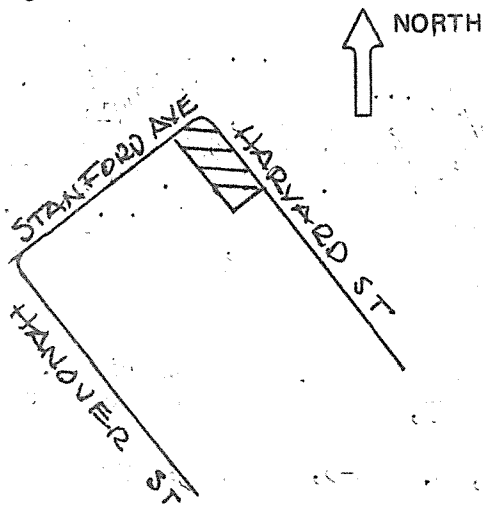

- Approximate property size:  
 Lot size (in feet) Frontage 45  
 Depth 125  
 or approx. acreage \_\_\_\_\_
- Condition: (check one)  
 a. Excellent  b. Good  c. Fair   
 d. Deteriorated  e. No longer in existence
- Is the feature a. Altered?  b. Unaltered?
- Surroundings: (Check more than one if necessary)  
 a. Open land  b. Scattered buildings   
 c. Densely built-up  d. Residential   
 e. Commercial  f. Industrial   
 g. Other
- Threats to site:  
 a. None known  b. Private development   
 c. Zoning  d. Public Works project   
 e. Vandalism  f. Other
- Date(s) of enclosed photograph(s): 1978

1215 Stanford

NOTE: The following (Items 14-19) are for structures only.

14. Primary exterior building material: a. Stone  b. Brick  c. Stucco  d. Adobe  e. Wood   
f. Other
15. Is the structure: a. On its original site?  b. Moved?  c. Unknown?
16. Year of initial construction ca. 1905 This date is: a. Factual  b. Estimated
17. Architect (if known): \_\_\_\_\_
18. Builder (if known): \_\_\_\_\_
19. Related features: a. Barn  b. Carriage house  c. Outhouse  d. Shed(s)  e. Formal garden(s)   
f. Windmill  g. Watertower/tankhouse  h. Other  i. None

SIGNIFICANCE

20. Briefly state historical and/or architectural importance (include dates, events, and persons associated with the site when known):

A good example of a standard type. In 1889, Peter Grimley bought the entire Stanford Avenue frontage of the block on which the house stands and six years later deeded the lots to his wife, Mary. It is thought that the house (with its next-door twin) was built about 1905, perhaps by Grimley's son John, then in construction work. It was used as rental property, since the Grimleys lived on El Camino Real, where they conducted a hotel and livery business. By 1910 the house was occupied by Daniel and Margaret Harrington and their children; they purchased the property in 1920. Harrington was a section foreman for the Southern Pacific railroad. In 1932 the Harringtons deeded the house to their daughter Anne, retaining a life interest in it. Mrs. Harrington moved to San Francisco to live with Anne after her husband's death in 1940. The house then was rented until 1953 to John H. and Doris Moon; Moon was a butcher for Liddicoat's Market and for Purity Stores. From 1954-65 the tenant was Charles K. Hurtig, a carpenter working for the Schmaling and Stenbit firm of contractors. Anne Harrington sold the property in 1963 to David H.L. and \*\*\*

21. Main theme of the historic resource: (Check only one): a. Architecture  b. Arts & Leisure   
c. Economic/Industrial  d. Exploration/Settlement  e. Government  f. Military   
g. Religion  h. Social/Education
22. Sources: List books, documents, surveys, personal interviews, and their dates: P.A. City Directories; U.S. Census 1910, ED 75; A.A.U.W. notes for "...Gone Tomorrow?" in P.A.Hist. Assn. archives; P.A. Times 11/24/25, 6/21/40, 6/1/48, 10/23/51, 7/24/71; Book 121 (Deeds), p. 386, 11/11/89; Book 187 (Deeds), p. 127, 8/7/95; Book 519 (Deeds), p. 347, 9/21/20; Book 519 (Deeds), p. 449, 10/19/20; Book 2316 (Off. Rec.), p. 369, 9/13/32; \*\*\*
23. Date form prepared: 1981, 1986 By (name): Historic Resources Board; P.A. Hist. Assn.  
Address: 250 Hamilton Ave City Palo Alto, Ca ZIP: 94301  
Phone: \_\_\_\_\_ Organization: \_\_\_\_\_

(State Use Only)

\*\*\* Hsiao Lan-Lee Tseng, who passed it on to Walter E. and Patricia A. Sonnenstuhl two years later. It was their home until 1973, when the present owners acquired it.

\*\*\* Sources cont'd: book 6099 (Off. Rec.), p. 682-5, 5/29/63; Book 7183 (Off. Rec.) p. 573-4, 11/19/65 (Santa Clara Co. Recorder)

HISTORIC RESOURCES INVENTORY

(State use only)  
 Ser \_\_\_\_\_ Site \_\_\_\_\_ Mo. \_\_\_\_\_ Yr. \_\_\_\_\_  
 UTM \_\_\_\_\_ Q \_\_\_\_\_ NR \_\_\_\_\_ SHL \_\_\_\_\_  
 Lat \_\_\_\_\_ Lon \_\_\_\_\_ Era \_\_\_\_\_ Sig \_\_\_\_\_  
 Adm \_\_\_\_\_ T2 \_\_\_\_\_ T3 \_\_\_\_\_ Cat \_\_\_\_\_ HABS \_\_\_\_\_ HAER \_\_\_\_\_ Fed \_\_\_\_\_

IDENTIFICATION Cat. II

1. Common name: \_\_\_\_\_
  2. Historic name, if known: \_\_\_\_\_
  3. Street or rural address 1229 Stanford Avenue (early address, 821 Stanford Ave.)  
 City: Palo Alto ZIP: \_\_\_\_\_ County: Santa Clara
  4. Present owner, if known: Rosa Steck Address: 1983 Euclid Avenue  
 City: Menlo Park, Ca ZIP: 94025 Ownership is: Public  Private
  5. Present Use: Residence Original Use: Residence
- Other past uses: \_\_\_\_\_

DESCRIPTION

6. Briefly describe the present physical appearance of the site or structure and describe any major alterations from its original condition:

This restrained one-story Queen Anne cottage with its porch, bay window, and bands of patterned shingles exhibits the vernacular interpretation of a standard nineteenth century form. Before the installation of a larger window in the gable, this house was a twin of 1215 Stanford Avenue.

7. Locational sketch map (draw and label site and surrounding streets, roads, and prominent landmarks):

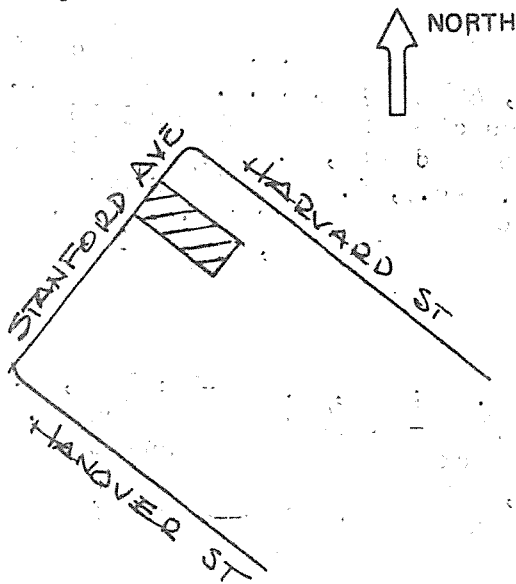

8. Approximate property size:  
 Lot size (in feet) Frontage 45  
 Depth 125  
 or approx. acreage \_\_\_\_\_
9. Condition: (check one)  
 a. Excellent  b. Good  c. Fair   
 d. Deteriorated  e. No longer in existence
10. Is the feature a. Altered?  b. Unaltered?
11. Surroundings: (Check more than one if necessary)  
 a. Open land  b. Scattered buildings   
 c. Densely built-up  d. Residential   
 e. Commercial  f. Industrial   
 g. Other
12. Threats to site:  
 a. None known  b. Private development   
 c. Zoning  d. Public Works project   
 e. Vandalism  f. Other
13. Date(s) of enclosed photograph(s): 1976

1229 Stanford

NOTE: The following (Items 14-19) are for structures only.

14. Primary exterior building material: a. Stone  b. Brick  c. Stucco  d. Adobe  e. Wood   
 f. Other  \_\_\_\_\_
15. Is the structure: a. On its original site?  b. Moved?  c. Unknown?
16. Year of initial construction ca. 1905 This date is: a. Factual  b. Estimated
17. Architect (if known): \_\_\_\_\_
18. Builder (if known): \_\_\_\_\_
19. Related features: a. Barn  b. Carriage house  c. Outhouse  d. Shed(s)  e. Formal garden(s)   
 f. Windmill  g. Watertower/tankhouse  h. Other  \_\_\_\_\_ i. None

SIGNIFICANCE

20. Briefly state historical and/or architectural importance (include dates, events, and persons associated with the site when known):

A good example of a standard type. From 1889 to 1920 the property belonged to Peter and Mary Grimley, and the house probably was built by their son, John—see 1215 Stanford Avenue for further particulars. Members of the Daniel Harrington family, among others, were among tenants during the decade from 1910-1920. It then was sold through the realtor Charles Ellet and others to William McCullough (1924) and from the McCullough estate to Vincent and Rosa Steck (1939). Tenants during these years included George M. and Lillian Mead (Mead owned a Mayfield sheet-metal firm) (1928-31); J.E. Capovilla (1933-1937); Patrick W. and Bernita Neely (1939-53) (Neely was a field engineer for the Durant Pipe Co.). The house has continued to be owned by the Steck family, occupied after the mid-fifties for a time by Vincent (Jr.) and Patricia Steck, and since then by Joseph E. and Jeanette J. Steck. The late Vincent Steck, Jr. was an engineer with Varian Associates.

21. Main theme of the historic resource: (Check only one): a. Architecture  b. Arts & Leisure   
 c. Economic/Industrial  d. Exploration/Settlement  e. Government  f. Military   
 g. Religion  h. Social/Education

22. Sources: List books, documents, surveys, personal interviews, and their dates: P.A. City Directories; P.A. Times 7/9/51, 1/10/55, 11/7/68, 1/18/69, 4/14/82; A.A.U.W. notes for "...Gone Tomorrow?" in P.A. Hist. Assn. archives; deeds cited in sources for 1215 Stanford 1889-1920 and, for 1229 Stanford Ave., Book 500 (Deeds), p. 361, 3/8/21; Book 88 (Off. Rec.), p. 307-9, 5/31/24; Book 67 (Off. Rec.), p. 53, 1/5/24; ~~\*\*\*~~

23. Date form prepared: 1978, 1986 By (name): Historic Resources Board; P.A. Hist. Assn.  
 Address: 250 Hamilton Ave City Palo Alto, Ca 94301 ZIP: \_\_\_\_\_  
 Phone: \_\_\_\_\_ Organization: \_\_\_\_\_

(State Use Only)

\*\*\* Sources, cont'd: Books 948, p. 56; 950, p. 92; 951, p. 210-11; 1007, p. 26 (Off. Rec. pertaining to McCullough estate), 8/9/39-9/13/40 (Santa Clara Co. Recorder); interview 1986, Patricia Steck, Joseph Steck (the latter reports the Harrington name scratched on brick in the basement, although Harringtons only rented; and that he had heard the house was built by a sheep rancher—John Grimley was a rancher in his later years).