

### **Fence Permit Eliminated**

No fence permit is required per Palo Alto Municipal Code (PAMC) Section 16.48.050. All fences shall be constructed according to PAMC fence ordinance. If Architectural Review Board (ARB) approval is required for a fence, the ARB or variance approval from Planning is sufficient. No building permit is required.

### **Encroachment Permits**

Fences to be erected or replaced that are located in a public utility easement require an encroachment permit from the Public Works Department.

## Chapter 16.24 FENCES\*

Sections:

- 16.24.010 Definitions.
- 16.24.020 Standard fences - Height and location regulations.
- 16.24.030 Special fences - Height and regulations.
- 16.24.040 Fences at intersections.
- 16.24.050 Fences on residential lots abutting frontage roads.
- 16.24.060 Fences on corner lots.
- 16.24.065 Fences on through lots.
- 16.24.070 Prohibited fences.
- 16.24.080 Violations - Penalty - Enforcement.
- 16.24.090 Variances.

\* Editor's Note: Prior ordinance history: Prior code §§ 34.501 - 34.510, and Ordinance Nos. 2104, 2863, 2865 and 2960.

### **16.24.010 Definitions.**

Throughout this chapter, the following definitions shall apply:

(a) Height Measurement. Except as otherwise provided in this chapter, height of fences or walls between the setback line and lot line shall be measured from natural grade, as determined by the chief building official.

(b) "Lot line" means any boundary of a lot. Definitions of front, interior, rear, side and street lot lines shall be those contained in Chapter 18.04 of this code.

(c) "Street setback line" means a line established by this code or any ordinance of the city of Palo Alto to govern the placement of buildings with respect to streets and alleys, and shall be measured from the lot line.

(d) Definitions of all "yards" (front, interior, rear, side and street yards) shall be those contained in Chapter 18.04 of this code, or as required by the special setbacks of Chapter 20.08 of this code.

(Ord. 3754 § 1 (part), 1987)

### **16.24.020 Standard fences - Height and location regulations.**

(a) Fences Between the Street Setback Line and the Lot Line. A fence, wall, or other structure in the nature of a fence located between the street setback line and the lot line, shall be permitted up to four feet in height, except as otherwise provided in this chapter. Support posts or columns, not exceeding five feet in height or eighteen inches in width, and pedestrian gates and trellises used as entryway features, not exceeding eight feet in height, three feet in depth or five feet in width shall be permitted.

(b) Fences Beyond Setback Line.

(1) Front Yards and Street Side Yards. A fence, wall, or other structure in the nature of a fence, located beyond the street setback line in a front yard or other street side yard shall not exceed six feet in height, except that, where a street setback line exceeds sixteen feet, such fences or walls may be constructed to within sixteen feet of the lot line.

(2) Interior Side Yards and Rear Yards. A fence, wall or other structure in the nature of a fence, located beyond the street setback line in an interior side yard or rear yard, shall not exceed seven feet in height, except that where a street setback line exceeds sixteen feet, such fences or walls may be constructed to within sixteen feet of the lot line.

(c) Fences on University Avenue. A fence, wall or other structure in the nature of a fence, up to six feet in height, except as otherwise provided in Section 16.24.040, may be located within the front and street side yard setbacks on residential property having street frontage on University Avenue, between Middlefield Road and the eastern city limit, provided that the fence complies with the following:

- (1) Fences shall be located on private property, no closer than five feet from the edge of the sidewalk nearest the house;
- (2) Structural and decorative posts or columns, not exceeding seven feet in height or eighteen inches in width, and spaced no closer than six feet apart, from center to center, shall be permitted;
- (3) The color, material and design of the fence shall be compatible with the architecture of the main dwelling unit on the site;
- (4) Screen landscaping and associated irrigation shall be installed and maintained on the street side of the fence;
- (5) Fences exceeding four feet in height shall not be located within a triangular area (a "sight distance triangle") measured from a driveway, as shown in Figure 1\*. Gates, which when in an open position, are entirely outside of the "sight distance triangle" shall be permitted.

(d) Fences Adjacent to San Francisquito Creek Flood Control Expansion Area. A fence or wall up to ten feet in height may be located at the rear of any single family residential site adjacent to San Francisquito Creek and fronting on Edgewood Drive if the portion of the site subject to a permanent easement in favor of the Santa Clara Valley Water District (or its successor in interest) for flood control purposes is reconfigured after January 1, 2002.

(Ord. 4751 § 2, 2002; Ord. 4224 § 1, 1994; Ord. 3754 § 1 (part), 1987)

\* Editor's Note: Figure 1, referred to herein, may be found at this point in a printed edition of this code.

#### **16.24.030 Special fences - Height and regulations.**

The following special fences are permitted in accordance with the regulations contained in each subsection:

- (a) Fences Around Tennis Courts. Fences not to exceed twelve feet in height may be located around tennis courts, badminton courts, basketball or volleyball courts and similar play areas, providing that all parts of the fence over six feet are made of open wire construction of galvanized steel or other corrosion-resistant material, and that the fences are behind the zoning setback line.
- (b) School Fences. School play areas may be fenced to the street line; provided, that the fence is made of open wire construction and does not exceed ten feet in height.
- (c) Security Fences. Fences not to exceed eight feet in height may be located around industrial, manufacturing, or research uses where required for security purposes, screening, or containing hazardous materials.

(Ord. 3754 § 1 (part), 1987)

#### **16.24.040 Fences at intersections.**

A fence, wall or structure in the nature of a fence located at the intersection of any street improved for vehicular traffic, shall not exceed three feet in height above the adjacent curb grade, within a triangular area formed by the curblines, and their projection,

and a line connecting them at points thirty-five feet from the intersection of the projected curblines.

(Ord. 3754 § 1 (part), 1987)

**16.24.050 Fences on residential lots abutting frontage roads.**

Where residential properties abut frontage roads, railroad rights-of-way, industrial or commercial areas, or public property other than a public street, fences of solid board or similar materials may be constructed to a height not to exceed eight feet. The height of such fences behind a sixteen-foot setback line shall be measured from natural grade.

(Ord. 3754 § 1 (part), 1987)

**16.24.060 Fences on corner lots.**

Where corner lots are adjacent to each other with rear yards joining, a six-foot fence is permitted on the street side yard lot line at a point beginning fifty feet from the radius point of the corner, except that where a driveway occurs in that area, no fence may be constructed for a clear distance of twelve feet from the point of intersection of driveway and property lines. This provision shall not apply to corner lots whose rear or side yard abuts an interior side yard of an adjacent property.

(Ord. 3754 § 1 (part), 1987)

**16.24.065 Fences on through lots.**

On a through lot, a six-foot fence is permitted on the rear lot line. The rear lot line is the property line abutting the street that does not provide the primary access to the lot.

(Ord. 4081 § 2, 1992)

**16.24.070 Prohibited fences.**

The following type fences are prohibited and are a nuisance constituting an unsafe and unlawful condition, and may be abated pursuant to Chapter 9.56 of this code:

- (a) Barbed wire fences;
- (b) All wire, twine or rope fences consisting of one or more strands of wire, twine or rope less than three feet in height and within three feet of any public sidewalk.

(Ord. 3754 § 1 (part), 1987)

**16.24.080 Violations - Penalty - Enforcement.**

(a) No person shall erect, construct or maintain any fence, wall or structure in the nature of a fence which does not meet the requirements of this section.

(b) Violation of any provision of this chapter is an infraction, punishable as provided in this code. Each day of violation constitutes a separate offense and may be separately punished.

(c) Persons employed in the following designated employee positions are authorized to exercise the authority provided in Penal Code Section 836.5 and are authorized to issue citations for violations of this chapter: chief building official, assistant building official and code enforcement officer.

(Ord. 4305 § 8, 1995; Ord. 3754 § 1 (part), 1987)

**16.24.090 Variances.**

A variance to any of the requirements of this chapter may be granted in accordance with the provisions and procedures set forth in Chapters 18.90 and 18.92 of

this code, except that no variance may be granted to the requirements contained in Section 16.24.040 or 16.24.070. Application submittal requirements and fees shall be the same as for a zoning variance application, as set forth in Chapter 18.90 of this code and in the municipal fee schedule.  
(Ord. 3754 § 1 (part), 1987)

Note: Fences required for swimming pools are governed by the Uniform Building Code, Appendix Chapter 4, Section 421 as amended by PAMC. A separate informational handout is available for the public.

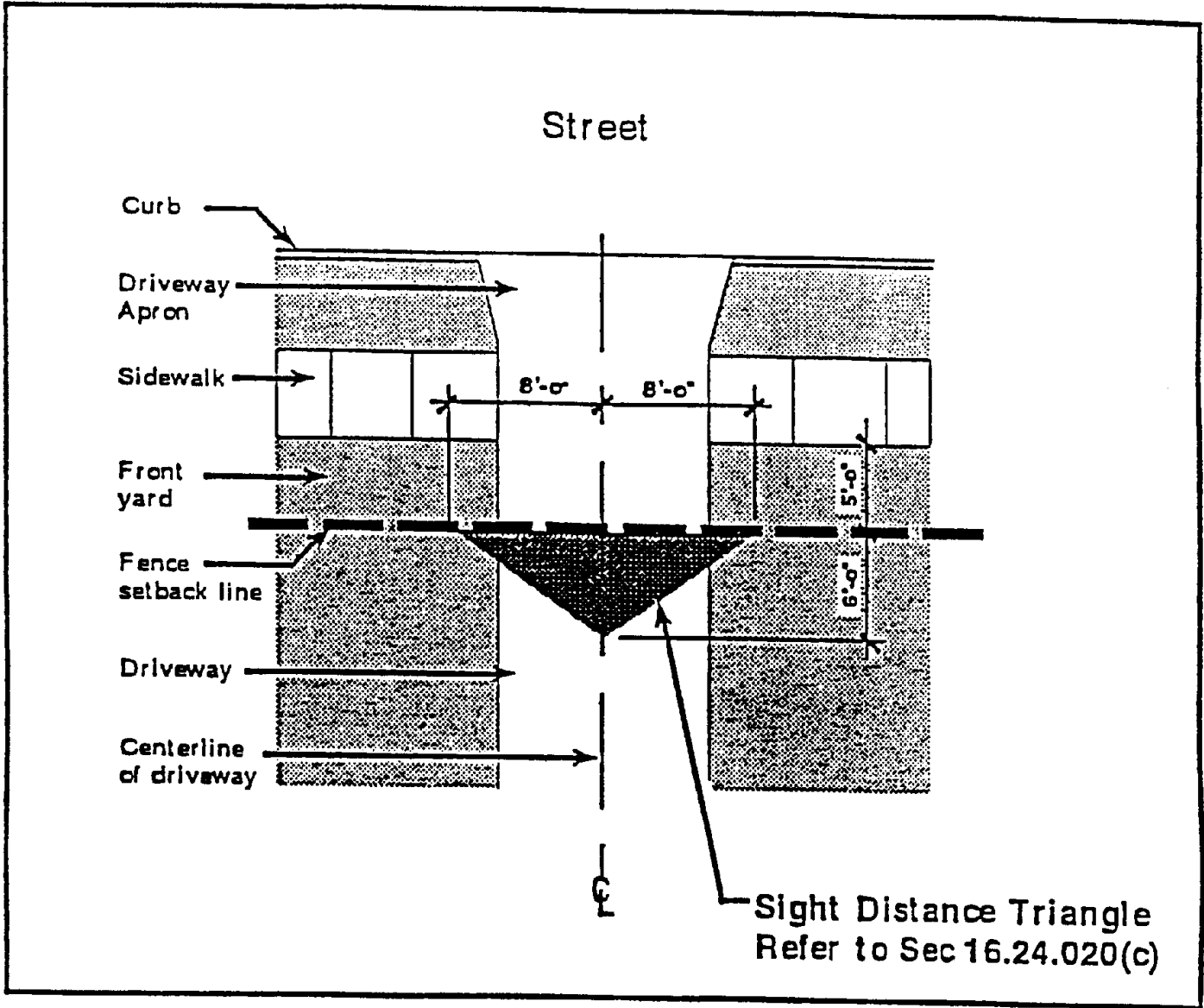
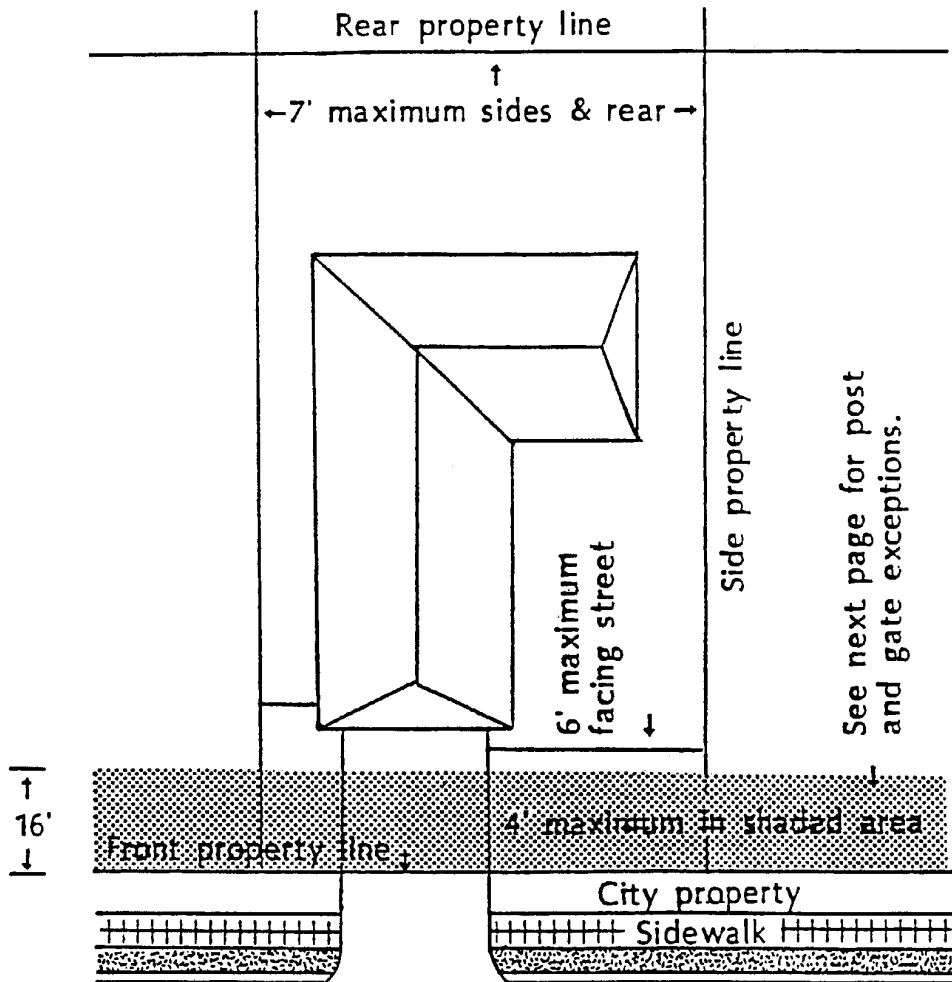

Figure 1

# STANDARD FENCES – INTERIOR LOTS



Palo Alto Municipal Code

References:

Definitions	16.24.010
4' fences	16.24.020(a)
6' fences	16.24.020(b)(1)
7' fences	16.24.020(b)(2)
Posts & gates	16.24.020(a)

NOTE: Your street-side property line may not begin at the sidewalk. The location of the property line may vary from 0' to 10' in from the inside edge of the sidewalk. Check at the Planning Division counter for the location of your street-side property line.

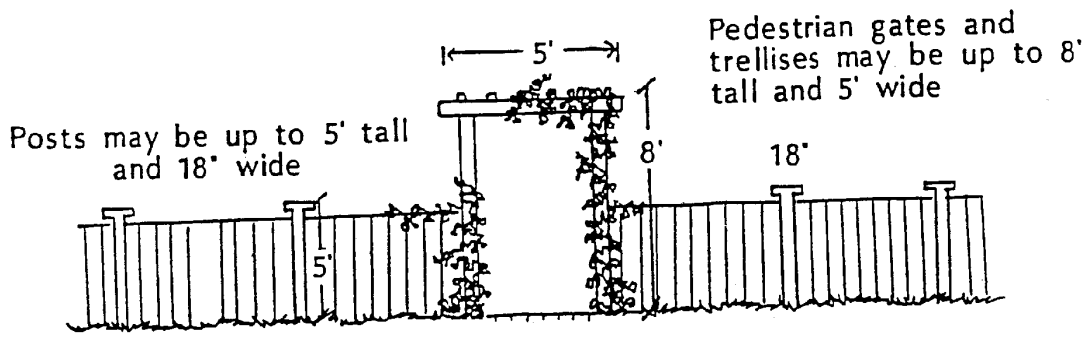

Exceptions for posts and gates  
in 4' fence  
16.24.020(a)

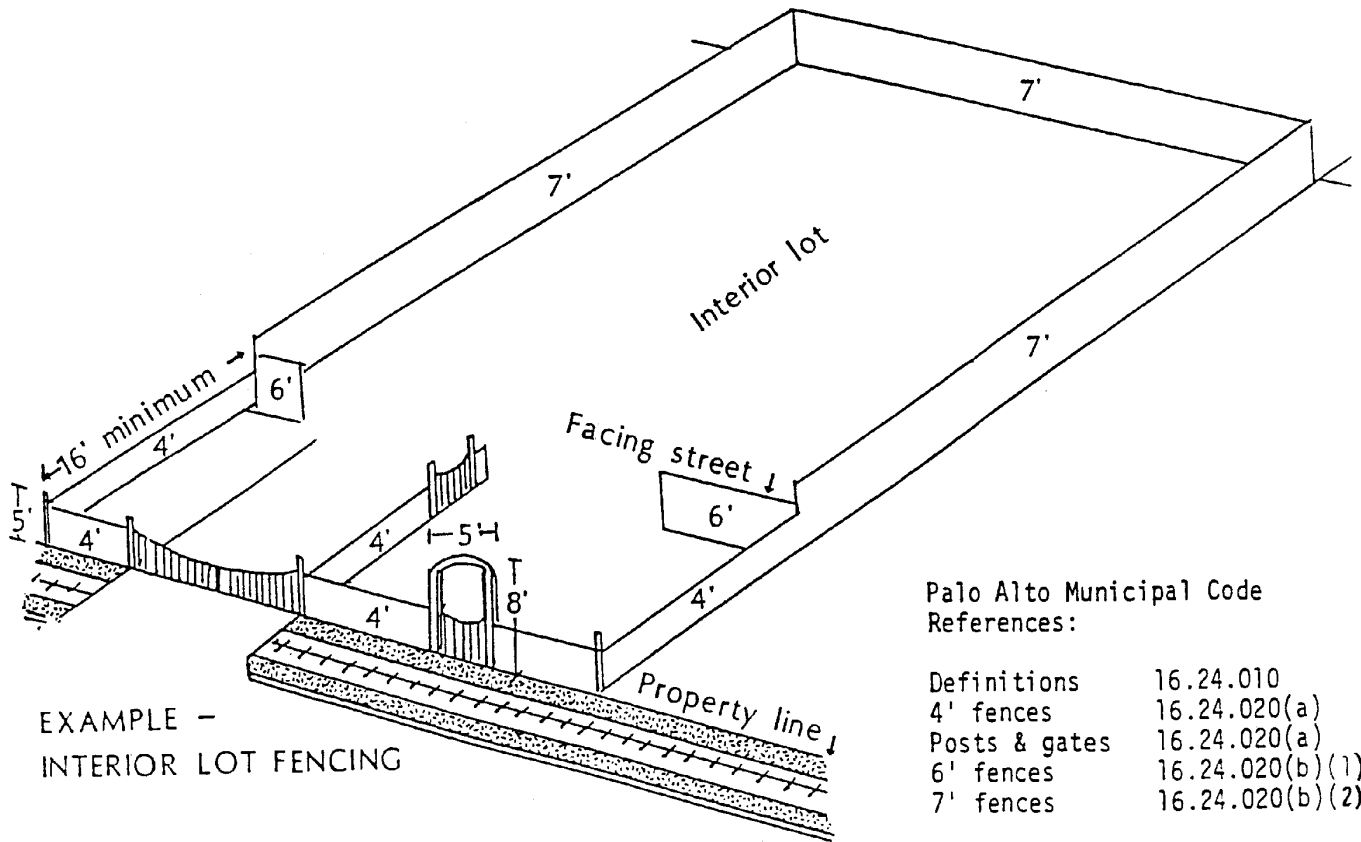

Palo Alto Municipal Code  
References:

Definitions	16.24.010
4' fences	16.24.020(a)
Posts & gates	16.24.020(a)
6' fences	16.24.020(b)(1)
7' fences	16.24.020(b)(2)



# STANDARD FENCES – CORNER LOTS

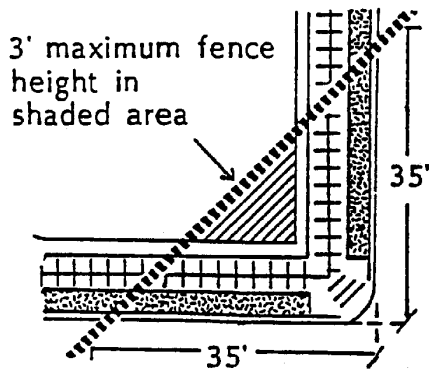
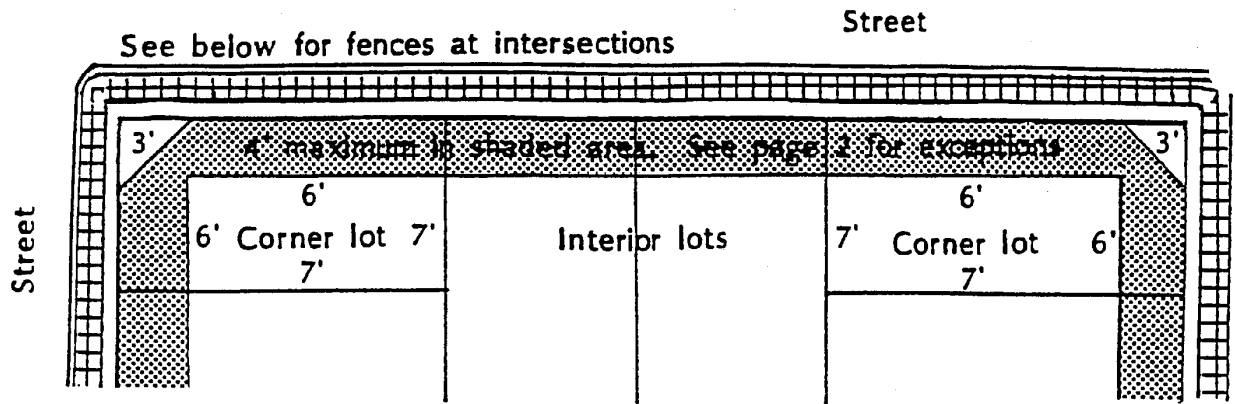

3' maximum fence height, measured from adjacent curb, within triangle formed by curb lines (and their projection) and a line connecting them at points 35' from the intersection of these projected curb lines. 16.24.040

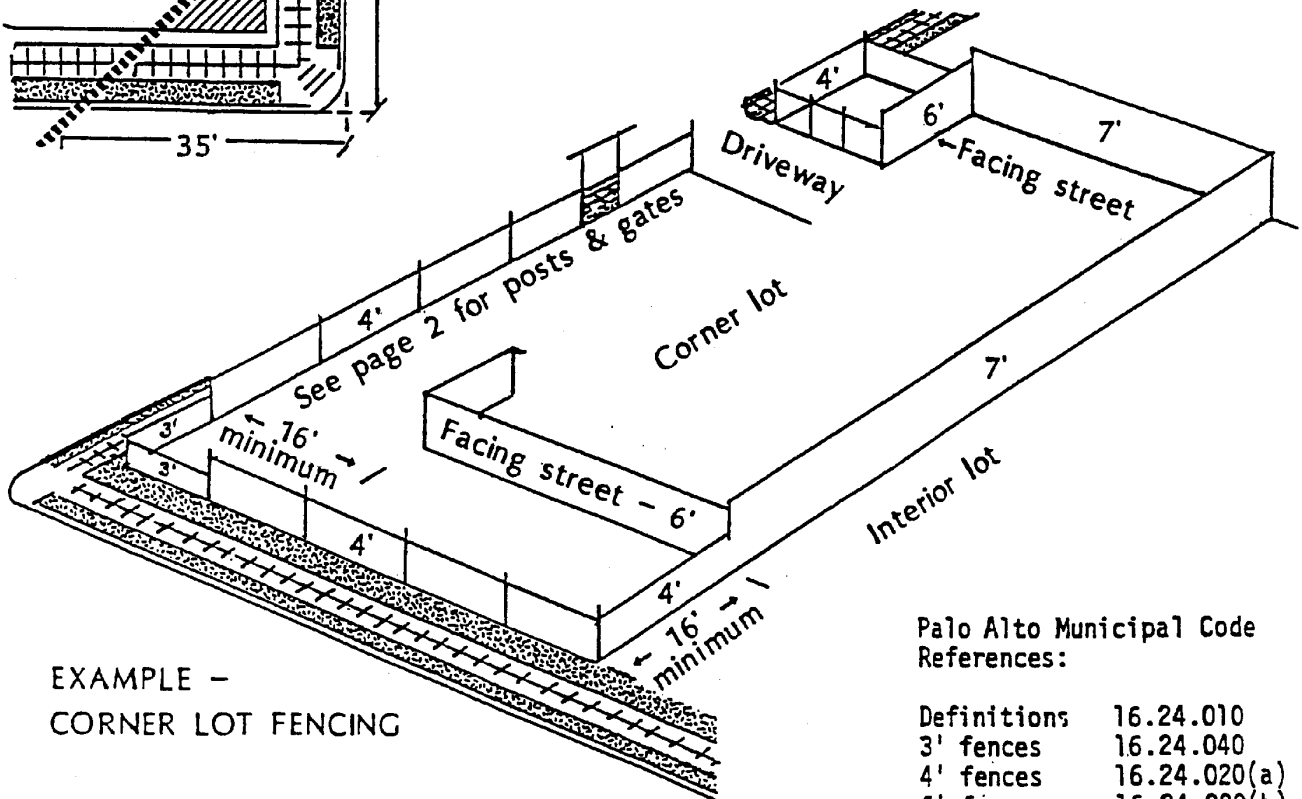

EXAMPLE –  
CORNER LOT FENCING

Palo Alto Municipal Code  
References:

Definitions	16.24.010
3' fences	16.24.040
4' fences	16.24.020(a)
6' fences	16.24.020(b)
7' fences	16.24.020(b)
Posts & gates	16.24.02(a)

# SPECIAL FENCES - BACK-TO-BACK CORNER LOTS

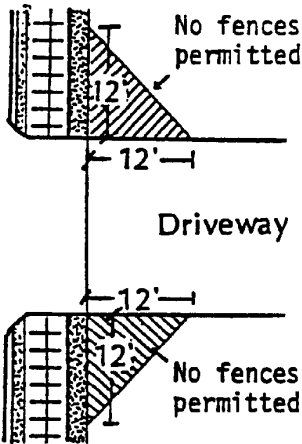
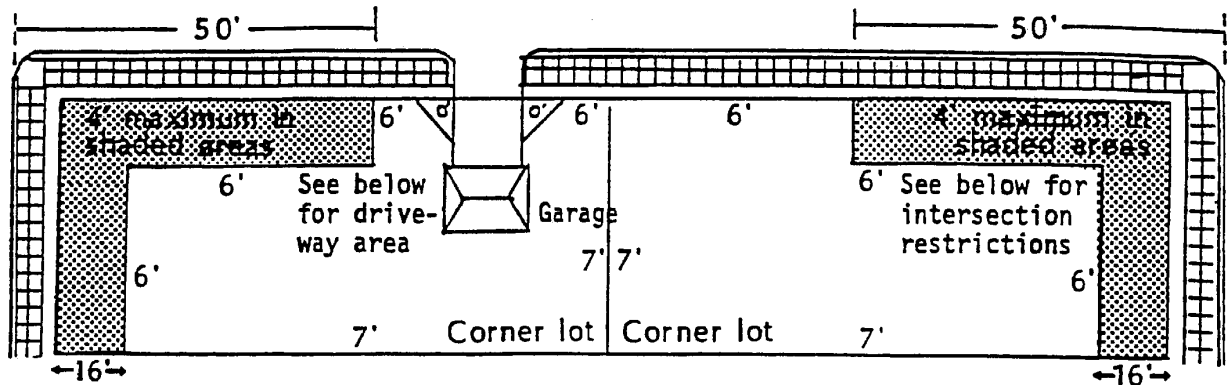

FENCES AT DRIVEWAYS

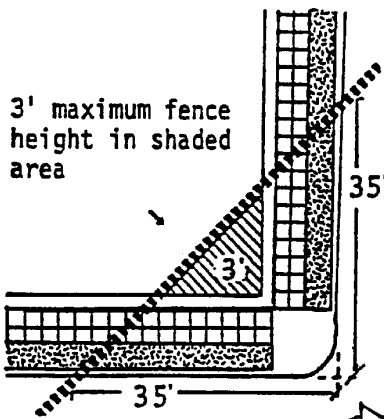

## FENCES AT INTERSECTION

3' maximum fence height measured from adjacent curb, within triangle formed by curb lines (and their projection) and a line connecting them at points 35' from the intersection of these projected curb line

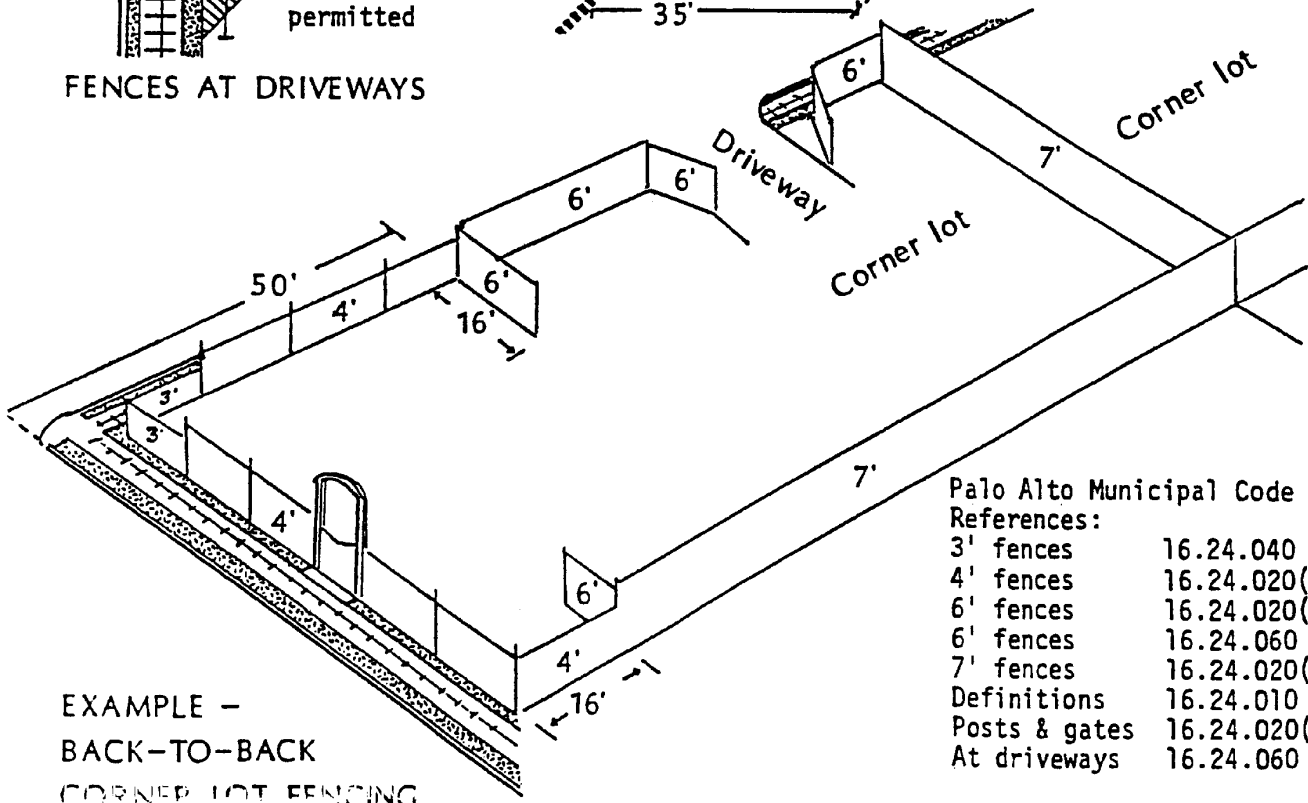

## Palo Alto Municipal Code

### References:

3' fences	16.24.040
4' fences	16.24.020(a)
6' fences	16.24.020(b)(1)
6' fences	16.24.060
7' fences	16.24.020(b)(2)
Definitions	16.24.010
Posts & gates	16.24.020(a)
At driveways	16.24.060

## OTHER SPECIAL FENCES, PROHIBITED FENCES, PERMITS AND VARIANCES

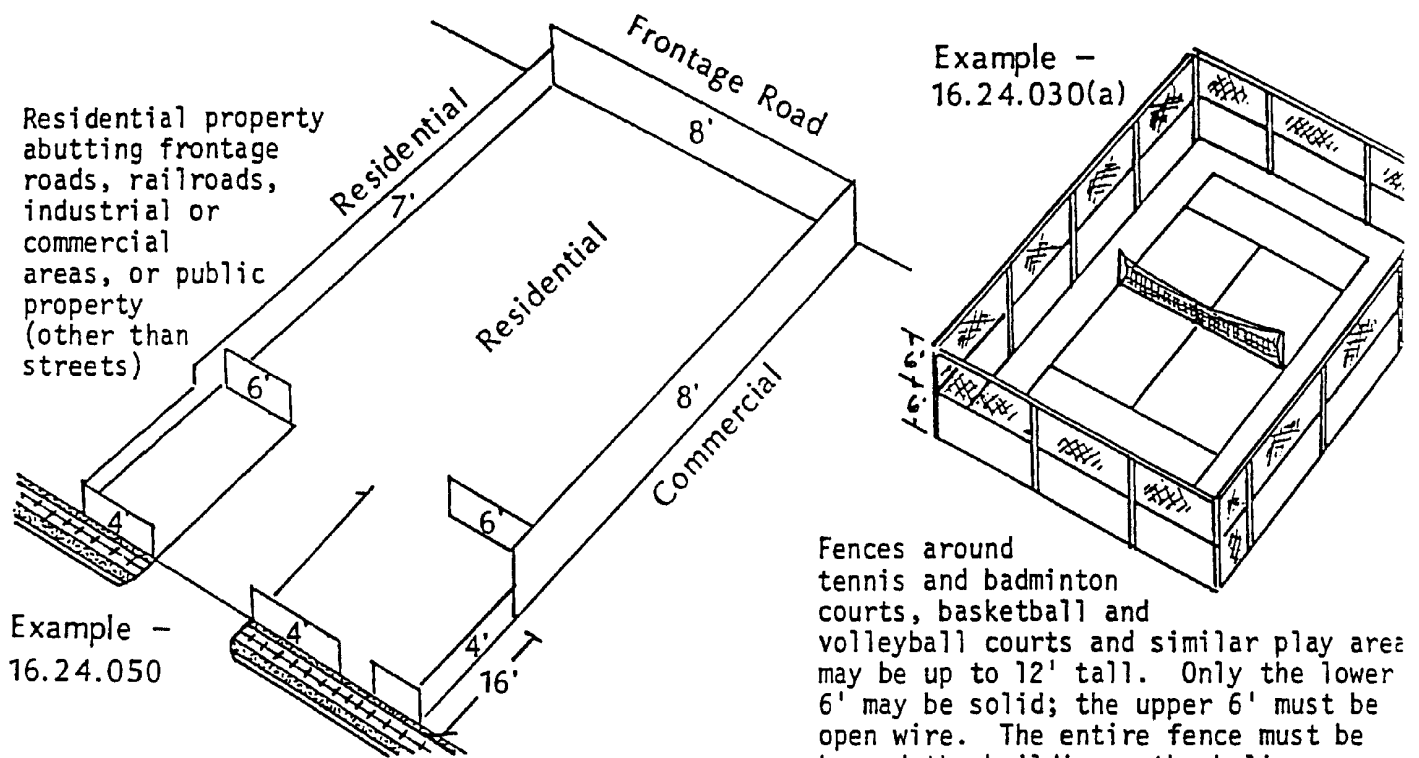

Fences around tennis and badminton courts, basketball and volleyball courts and similar play area may be up to 12' tall. Only the lower 6' may be solid; the upper 6' must be open wire. The entire fence must be beyond the building setback line.  
(R-1: 6' or 8' sideyard, 20' front and rear yard. R-E: 15' sideyard, 30' front and rear yard.

### Fences around school play yards:

May be fenced to street line.  
Fence may be 10' high, and must be open wire. 16.24.030(b)

### Security fences:

Fences around industrial, manufacturing or research uses or where required for security, screening or containing hazardous materials, may be up to 8' high. 16.24.030(c)

### Architectural Review Board Approval:

Fences erected on property used for anything other than single family dwellings or duplexes require ARB approval, as do fences built in zones requiring site and design review.

### Prohibited fences:

- Barbed wire fences
- Wire, twine or rope fences consisting of one or more strands less than 3' in height and within 3' of any public sidewalk. 16.24.070

### Variations:

Variations may be considered for any of the requirements of the fence ordinance except for the sections governing fences at intersections and prohibited fences. A variation must be applied for and approved by the Zoning Administrator. 16.24.090