



Architectural Review Board Regular Meeting Agenda: February 18, 2021

Virtual Meeting
8:30 AM

*****BY VIRTUAL TELECONFERENCE ONLY*****

<https://zoom.us/join>

Meeting ID: 961 9160 1296

Phone number: 1 669 900 6833

Pursuant to the provisions of California Governor's Executive Order N-29-20, issued on March 17, 2020, to prevent the spread of Covid-19, this meeting will be held by virtual teleconference only, with no physical location. The meeting will be broadcast live on Cable TV and through Channel 26 of the Midpen Media Center at bit.ly/MidPenwatchnow.

Members of the public may comment by sending an email to arb@cityofpaloalto.org or by attending the Zoom virtual meeting to give live comments. Instructions for the Zoom meeting can be found on the last page of this agenda. Visit bit.ly/PAPendingprojects to view project plans and details.

Call to Order / Roll Call

Oral Communications

The public may speak to any item not on the agenda. Three (3) minutes per speaker.^{1,2}

Agenda Changes, Additions, and Deletions

The Chair or Board majority may modify the agenda order to improve meeting management.

City Official Reports

1. Transmittal of 1) the ARB Meeting Schedule and Attendance Record, 2) Tentative Future Agenda items and 3) Recent Project Decisions

Study Session

Public Comment is Permitted. Three (3) minutes per speaker.^{1,3}

2. Study Session for Architectural Review Board Review of Draft Objective Standards That Would Modify Title 18 (Zoning Ordinance) of the Palo Alto Municipal Code

-
1. Spokespersons that are representing a group of five or more people who are identified as present at the meeting at the time of the spokesperson's presentation will be allowed up to fifteen (15) minutes at the discretion of the Chair, provided that the non-speaking members agree not to speak individually.
 2. The Chair may limit Oral Communications to 30 minutes for all combined speakers.
 3. The Chair may reduce the allowed time to speak to two minutes or less to accommodate a larger number of speakers.

Action Items

Public Comment is Permitted. Applicants/Appellant Teams: Ten (10) minutes, plus ten (10) minutes rebuttal. All others: Three (3) minutes per speaker.^{1,3}

3. PUBLIC HEARING / QUASI-JUDICIAL. 650 Clark Way [20PLN-00134]: Recommendation on Applicant's Request for Approval of a Major Architectural Review to allow in-channel creek bank stabilization of the Children's Health Council property. The proposed project will install a live log crib wall with a rock toe within San Francisquito Creek to prevent future erosion impacts. Environmental Assessment: A Mitigated Negative Declaration (MND) was circulated from February 5, 2021 to March 7, 2021 in accordance with CEQA. Zoning District: PF (Public Facilities). For more information contact the Project Planner at Claire.raybould@Cityofpaloalto.org.

Board Member Questions, Comments or Announcements

North of Ventura Coordinated Area Plan (NVCAP) Working Group Updates –
Boardmember Lew

Adjournment

-
1. Spokespersons that are representing a group of five or more people who are identified as present at the meeting at the time of the spokesperson's presentation will be allowed up to fifteen (15) minutes at the discretion of the Chair, provided that the non-speaking members agree not to speak individually.
 2. The Chair may limit Oral Communications to 30 minutes for all combined speakers.
 3. The Chair may reduce the allowed time to speak to two minutes or less to accommodate a larger number of speakers.

Palo Alto Architectural Review Board

Boardmember Biographies, Present and Archived Agendas and Reports are available online: <http://www.cityofpaloalto.org/gov/boards/architectural/default.asp>. The ARB Boardmembers are:

Chair Osma Thompson
Vice Chair Grace Lee
Boardmember Peter Baltay
Boardmember David Hirsch
Boardmember Alex Lew

Get Informed and Be Engaged!

View online: <http://midpenmedia.org/category/government/city-of-palo-alto/> or on Channel 26.

Public comment is encouraged. Email the ARB at: arb@CityofPaloAlto.org.

Material related to an item on this agenda submitted to the ARB after distribution of the agenda packet is available for public inspection at bit.ly/paloaltoARB.

Americans with Disability Act (ADA)

It is the policy of the City of Palo Alto to offer its public programs, services and meetings in a manner that is readily accessible to all. Persons with disabilities who require materials in an appropriate alternative format or who require auxiliary aids to access City meetings, programs, or services may contact the City's ADA Coordinator at (650) 329-2550 (voice) or by emailing ada@cityofpaloalto.org. Requests for assistance or accommodations must be submitted at least 24 hours in advance of the meeting, program, or service.

-
1. Spokespersons that are representing a group of five or more people who are identified as present at the meeting at the time of the spokesperson's presentation will be allowed up to fifteen (15) minutes at the discretion of the Chair, provided that the non-speaking members agree not to speak individually.
 2. The Chair may limit Oral Communications to 30 minutes for all combined speakers.
 3. The Chair may reduce the allowed time to speak to two minutes or less to accommodate a larger number of speakers.

Public Comment Instructions

Members of the Public may provide public comments to teleconference meetings via email, teleconference, or by phone.

1. **Written public comments** may be submitted by email to arb@CityofPaloAlto.org
2. **Spoken public comments using a computer** will be accepted through the teleconference meeting. To address the Board, click on the link below for the appropriate meeting to access a Zoom-based meeting. Please read the following instructions carefully.
 - A. You may download the Zoom client or connect to the meeting in-browser. If using your browser, make sure you are using a current, up-to-date browser: Chrome 30+, Firefox 27+, Microsoft Edge 12+, Safari 7+. Certain functionality may be disabled in older browsers including Internet Explorer.
 - B. You will be asked to enter an email address and name. We request that you identify yourself by name as this will be visible online and will be used to notify you that it is your turn to speak.
 - C. When you wish to speak on an agenda item, click on “raise hand”. The moderator will activate and unmute attendees in turn. Speakers will be notified shortly before they are called to speak. The Zoom application will prompt you to unmute your microphone when it is your turn to speak.
 - D. When called, please limit your remarks to the time limit allotted.
 - E. A timer will be shown on the computer to help keep track of your comments.
3. **Spoken public comments using a smart phone** will be accepted through the teleconference meeting. To address the Council, download the Zoom application onto your phone from the Apple App Store or Google Play Store and enter the Meeting ID below. Please follow instructions B-E above.
4. **Spoken public comments using a phone** use the telephone number listed below. When you wish to speak on an agenda item hit *9 on your phone so we know that you wish to speak. You will be asked to provide your first and last name before addressing the Board. You will be advised how long you have to speak. When called please limit your remarks to the agenda item and time limit allotted.

<https://zoom.us/join>

Meeting ID: 961 9160 1296

Phone number: 1 669 900 6833

(you may need to exclude the initial “1” depending on your phone service)

-
1. Spokespersons that are representing a group of five or more people who are identified as present at the meeting at the time of the spokesperson’s presentation will be allowed up to fifteen (15) minutes at the discretion of the Chair, provided that the non-speaking members agree not to speak individually.
 2. The Chair may limit Oral Communications to 30 minutes for all combined speakers.
 3. The Chair may reduce the allowed time to speak to two minutes or less to accommodate a larger number of speakers.



Architectural Review Board

Staff Report (ID # 12013)

Report Type: City Official Reports **Meeting Date:** 2/18/2021

Summary Title: City Official Report

Title: Transmittal of 1) the ARB Meeting Schedule and Attendance Record, 2) Tentative Future Agenda items and 3) Recent Project Decisions

From: Jonathan Lait

Recommendation

Staff recommends the Architectural Review Board (ARB) review and comment as appropriate.

Background

The attached documents are provided for informational purposes. The Board may review and comment as it deems appropriate. If individual Boardmembers anticipate being absent from a future meeting, it is requested that be brought to staff's attention when considering this item.

The first attachment provides a meeting and attendance schedule for the current calendar year. Also included are the subcommittee assignments, which are assigned by the ARB Chair.

The second attachment is a Tentative Future Agenda that provides a summary of upcoming projects or discussion items. The hearing dates for these items are subject to change.

Board level Architectural Review approvals can be found on the City's webpage at <http://bit.ly/PAapprovedprojects>.

Administrative staff-level Architectural Review approvals can be found on the City's webpage at <http://bit.ly/PAstaffapprovals>. Any party, including the applicant, may request a hearing by the ARB on the proposed director's decision(s) by filing a written request with the planning division. There shall be no fee required for requesting such a hearing.

However, pursuant to 18.77.070(b)(5) any project relating to the installation of cabinets containing communications service equipment or facilities, pursuant to any service subject to Palo Alto Municipal Code Chapter 2.11, Chapter 12.04, Chapter 12.08, Chapter 12.09, Chapter

12.10, or Chapter 12.13 is not eligible for a request for hearing by any party, including the applicant.

No action is required by the ARB for this item.

Attachments:

- Attachment A: ARB Meeting Schedule Assignments (DOCX)
- Attachment B: Tentative Future Agendas (DOCX)



Architectural Review Board 2021 Meeting Schedule & Assignments

2021 Schedule

Meeting Dates	Time	Location	Status	Planned Absences
1/7/2021	8:30 AM	Cancelled	Regular	
1/21/2021	8:30 AM	Cancelled	Regular	
2/4/2021	8:30 AM	Virtual Meeting	Regular	
2/18/2021	8:30 AM	Virtual Meeting	Regular	
3/4/2021	8:30 AM	Virtual Meeting	Regular	
3/18/2021	8:30 AM	Virtual Meeting	Regular	
4/1/2021	8:30 AM	Virtual Meeting	Regular	
4/15/2021	8:30 AM	Virtual Meeting	Regular	
5/6/2021	8:30 AM	TBD	Regular	
5/20/2021	8:30 AM	TBD	Regular	
6/3/2021	8:30 AM	TBD	Regular	
6/17/2021	8:30 AM	TBD	Regular	
7/1/2021	8:30 AM	TBD	Regular	
7/15/2021	8:30 AM	TBD	Regular	
8/5/2021	8:30 AM	TBD	Regular	
8/19/2021	8:30 AM	TBD	Regular	
9/2/2021	8:30 AM	TBD	Regular	
9/16/2021	8:30 AM	TBD	Regular	
10/7/2021	8:30 AM	TBD	Regular	
10/21/2021	8:30 AM	TBD	Regular	
11/4/2021	8:30 AM	TBD	Regular	
11/18/2021	8:30 AM	TBD	Regular	
12/2/2021	8:30 AM	TBD	Regular	
12/16/2021	8:30 AM	TBD	Regular	

2021 Subcommittee Assignments

Assignments will be made by the ARB Chair on the day of the hearing

January

February

March

April

May

June

3/4 – Lee/Hirsch

July

August

September

October

November

December



Architectural Review Board 2021 Tentative Future Agenda

The Following Items are Tentative and Subject to Change:

Meeting Dates	Topics
March 4, 2021	<ul style="list-style-type: none">• 486 Hamilton: Mixed Use with Four Units (2nd Formal)• 4256 El Camino Real: Revisions Request for Garage Parking• 656 Lytton Ave: Subcommittee (Lee and Hirsch)



Architectural Review Board

Staff Report (ID # 11931)

Report Type: Study Session **Meeting Date:** 2/18/2021

Summary Title: ARB Review of Objective Standards

Title: Study Session for Architectural Review Board Review of Draft Objective Standards That Would Modify Title 18 (Zoning Ordinance) of the Palo Alto Municipal Code

From: Jonathan Lait

Recommendation

Staff recommends that the Architectural Review Board (ARB):

1. Review the draft objective standards that would modify Title 18 (Zoning Ordinance) of the Palo Alto Municipal Code (PAMC); and
2. Provide feedback to staff and consultants.

Report Summary

First, this report summarizes the outcomes of the ARB and ARB Subcommittee's most recent meetings on the objective standards project. Second, it describes changes to the draft standards based on ARB and ARB Subcommittee feedback, namely to sections on ground floor residential units, transitions to lower density districts, materials, zoning graphics, and sustainability guidelines and requirements. Third, the report presents additional proposed changes to Title 18 that will affect the ARB's review of future projects; these sections will be further reviewed by the Planning and Transportation Commission (PTC) this spring.

Background

State law relies more and more on projects' compliance with objective standards. Therefore, this project aims to strengthen objective standards for residential and residential mixed-use projects to identify the City's design and development priorities. In this way, the project seeks to ensure applicants' compliance with these priorities to facilitate the development of housing. Furthermore, this project allows the City to comply with recently passed State legislation requiring objective standards and streamlined approval processes.

Summary of Public Meetings

Staff and consultants met with the ARB, ARB Subcommittee, and Planning and Transportation Commission (PTC) over a series of meetings to outline the proposed project and discuss the draft standards. The below figure indicates with a red dot this ARB meeting, where this project is in the timeline.

Figure 1: Project Timeline

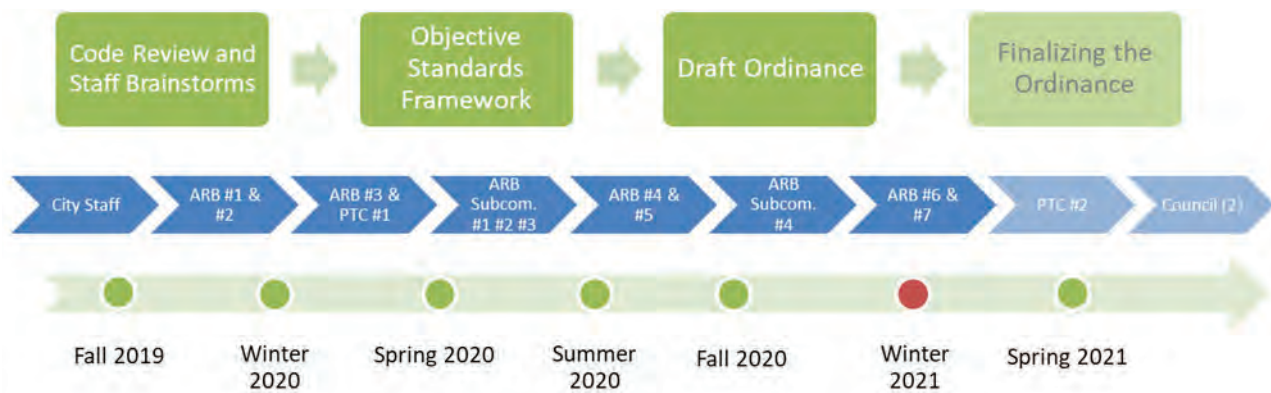

ARB Study Session – October 15, 2020¹ and November 19, 2020²

The full ARB met most recently in October and November 2020 to review the draft objective standards. Key discussions were as follows:

1. Framework: The ARB generally supported the structure of the draft ordinance, namely the “two-path” option wherein applicants could choose to meet the objective design standard or choose to meet the intent statement, as determined by the ARB through design review.
2. Applicability: The ARB recommended that new context-based design standards and intent statements apply to all residential and residential mixed-use project types with three or more units, regardless of the proportion of residential vs. commercial uses. Projects composed of non-residential uses would only need to comply with the intent statements and not the objective standards.
3. Design Topics: The ARB debated a number of design details, menu of options’ ideas, and specific measurements for individual design topics including site design, building orientation, building massing, and façade articulation.
4. Graphics: The ARB expressed a range of perspectives about draft zoning graphics and made recommendations for changes regarding height, style, and fenestration.

ARB Subcommittee – Summer 2020 and January 2021

The ARB formed a subcommittee, composed of Board members Thompson and Hirsch, to workshop the draft standards. The ARB Subcommittee reviewed and provided written comments on preliminary versions of the standards. The Subcommittee also met with staff and consultants over a series of four video meetings to discuss and debate the format, organization, intent statements, graphics, and specific language of the draft standards.

Staff and consultants also met with the full ARB and the PTC over a series of earlier meetings, as shown in Figure 1. Outcomes from these meetings are summarized in the November 19, 2020 staff report, which is footnoted herein. Additional information about each meeting is footnoted below:

¹ October 15, 2020 Staff Report: <https://www.cityofpaloalto.org/civicax/filebank/blobdload.aspx?BlobID=78749>, Minutes: <https://www.cityofpaloalto.org/civicax/filebank/documents/79279>, Video: <https://midpenmedia.org/architectural-review-board-74-10152020/>

² November 19, 2020 Staff Report: <https://www.cityofpaloalto.org/civicax/filebank/documents/79180>, Minutes: <https://www.cityofpaloalto.org/civicax/filebank/documents/79609>, Video: <https://midpenmedia.org/architectural-review-board-74-1152020-2/>

- ARB Study Sessions – December 5, 2019³, February 6, 2020⁴, and October 15, 2020
- PTC Study Session – May 13, 2020⁵

Discussion & Analysis

Context Based Design Standards

Staff and consultants have revised the current Context-Based Design Criteria into a stand-alone set of standards that would be codified as Chapter 18.24. Attachment #1 contains the draft design standards and related graphics. The Context-Based Design Criteria currently listed within several zoning district regulations would be eliminated from Title 18 with approval of these standards. The ARB findings would remain in Chapter 18.76. The ARB would continue to use these findings to evaluate projects that do not require compliance with objective standards (e.g., 100% commercial projects, projects that do not comply with the Housing Accountability Act).

Staff and consultants responded to items where there was ARB consensus and endeavored to draft appropriate standards for areas where there were differing opinions. Key changes since the full ARB's November 19th review of draft standards are as follows:

1. Ground Floor Residential Units - 18.24.040.B(iii): As presented at the end of the November 19th meeting, a series of new graphics establish a relationship between the setback of a residential unit from the back of walk, and the average height above the finished floor. These standards are intended to maintain privacy, while providing presence on the street.
2. Transitions to Lower Density Districts/Daylight Plane - 18.24.050.B(ii): The daylight plane requirement will remain in the district regulations, as illustrated in Figure 2. Standards for transitions between higher and lower density districts have been simplified to require: landscaping and trees in the confronting setback; façade breaks to provide light, air and visual relief; and limits on the amount of glazing to maintain privacy.

³ December 5, 2019 ARB Staff Report: <https://www.cityofpaloalto.org/civicax/filebank/documents/74248>, Minutes: <https://www.cityofpaloalto.org/civicax/filebank/documents/74670>, Video: <https://midpenmedia.org/architectural-review-board-74-1252019/>

⁴ February 6, 2020 ARB Staff Report: <https://www.cityofpaloalto.org/civicax/filebank/documents/75075>, Minutes: <https://www.cityofpaloalto.org/civicax/filebank/documents/75703>, Video: <https://midpenmedia.org/architectural-review-board-74-262020/>

⁵ May 13, 2020 PTC Staff Report: <https://www.cityofpaloalto.org/civicax/filebank/documents/76583>, Minutes: <https://www.cityofpaloalto.org/civicax/filebank/documents/77132>, Video: <https://midpenmedia.org/planning-transportation-commission-63-5132020/>

Figure 2: Illustration of Existing Daylight Plane

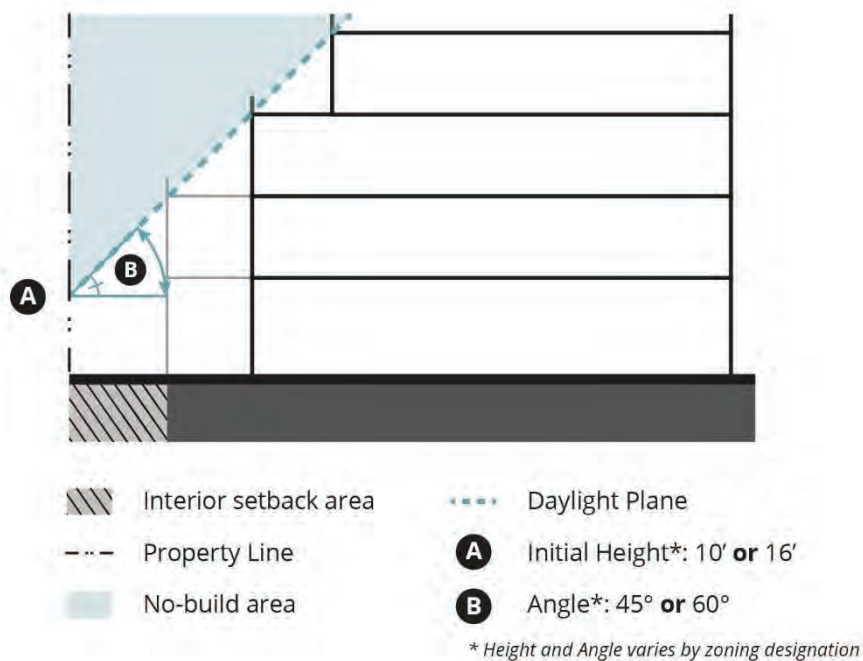

3. Materials - 18.24.090: Consultants have expanded on the previously provided example, and developed a matrix of allowed and prohibited materials.
4. Graphics – various sections: Following feedback from ARB members and the ARB Subcommittee, consultants revised graphics to isolate key standards, reduce building heights, and moderate architectural styles.
5. Sustainability and Green Building Design - 18.24.100: Staff and consultants added a section that retains the existing context-based design criteria regarding sustainability as an “intent statement.” This new section cross references existing sustainable design requirements in Chapter 18.44: Green Development Regulations and Chapter 16.14: Green Building Standards.

Other Changes to Title 18

As described in the February 6, 2020 ARB report, this objective standards project also addresses other portions of Title 18. Staff and consultants are proposing changes to the follow sections to streamline the development of housing. These changes may affect architectural review and the ARB’s role.

1. Reform Legislative Actions into Objective Criteria

Title 18 offers flexible development standards to facilitate multi-family and affordable housing projects but requires legislative actions in order for projects to access these standards. The legislative action adds time, expense, and uncertainty to the development process. The

Workforce Housing (WH), Affordable Housing (AH), and Pedestrian Transit Oriented Development (PTOD) combining overlays require action by the PTC and City Council prior to architectural review.

In contrast, the Housing Incentive Program (HIP) process allows more density/FAR without rezoning. Housing achievable under these overlays represent the very types of uses—housing affordable to low- and moderate-income households, and housing near transit—the City wishes to facilitate. The City could instead consider converting these overlay criteria into objective standards and allow these overlays to apply certain project types that meet specific criteria without legislative action (e.g., multi-family affordable projects that meet objective standards).

The PTC discussed this topic during their May 2020 study session and recommended that staff and consultants continue to pursue the idea. The PTC expressed a desire to retain opportunities for public review, but also to streamline the process for affordable housing and other desired project types.

2. Rewrite and Reorganize Performance Standards

Performance standards in PAMC Chapter 18.23 were originally conceived to address potential colocation impacts between residential and non-residential uses. However, this code section has been revised over time and has been interpreted to apply to all types of projects, regardless of adjacency. As a result, this section has been a source of confusion for City staff and applicants.

To clarify applicability and streamline requirements, staff and consultants propose to eliminate the catch-all 18.23 Performance Standards chapter and move those standards into more relevant code locations, as summarized in Table 1. Additionally, these code sections will be revised to strengthen objective standards and bring them up to date with current zero waste and stormwater management practices.

Table 1: Dispersing Performance Standards into Relevant Chapters

<i>Topic</i>	<i>Existing Location</i>	<i>Proposed Location</i>
Refuse Disposal Areas	18.23.020 Refuse Disposal Areas	18.40 (General Standard and Exceptions)
Lighting	18.23.030 Lighting	18.40 (General Standard and Exceptions)
Late Night Uses and Activities	18.23.040 Late Night Uses and Activities	18.42 (Standards for Special Uses)
Visual, Screening and Landscaping	18.23.050 Visual, Screening and Landscaping	18.40 (General Standard and Exceptions)
Noise and Vibration	18.23.060 Noise and Vibration	18.42 (Standards for Special Uses)
Parking	18.23.070 Parking	18.54 (Parking Facility Design Standards)
Vehicular, Pedestrian, and	18.23.080 Vehicular, Pedestrian,	18.54 (Parking Facility Design

<i>Topic</i>	<i>Existing Location</i>	<i>Proposed Location</i>
Bicycle Site Access	and Bicycle Site Access	Standards)

The PTC discussed this topic during their May 2020 study session and recommended that we continue to pursue the idea.

3. Mechanical Parking Lifts

Mechanical parking lifts have become a more common design solution for residential parking in the Bay Area. Currently, PAMC 18.54 requires Director or City Council approval for proposed mechanical lift parking systems. Staff and consultants propose to clarify design requirements for mechanical parking lifts and allow them by right. The ARB would continue to have an opportunity to review parking design as part of any project undergoing architectural review. An otherwise code compliant project, however, would not require approval by Director or City Council when mechanical lifts are proposed.

This idea has not yet been discussed with the PTC; nor has this or any of the ideas been discussed with City Council.

Next Steps

Based on feedback from the ARB, staff and consultants will prepare a final draft ordinance of objective design standards to share with the ARB at an action meeting on March 18, 2021. Staff expects that the PTC will conduct a study session on the draft objective standards and other changes to Title 18 on March 10, 2021.

Environmental Review

The ordinance revisions represent implementation of adopted plans and policy. Therefore, the revisions are exempt under CEQA and/or covered by the CEQA documents prepared for the Comprehensive Plan. The project aims to facilitate implementation of State law. The project does not propose to increase development beyond what was analyzed in the Comprehensive Plan.

Public Notification, Outreach & Comments

The Palo Alto Municipal Code does not require noticing of study sessions; however, this item was published in a local paper, *Daily Post*, on February XX, 2021, which is 13 days in advance of the meeting.

Public Comments

On January 22, 2021 staff sent an email to a wide range of architect and consultants that have worked with the City in the recent past on development projects to solicit comments on the draft objective standards. Of the 30 stakeholders emailed, three people provided feedback:

1. Elaine Uang provided detailed comments, including recommendations to provide more flexibility for different sized lots and lot configurations, and different locations (see Attachment #2)
2. Ken Hayes provided a link to a journal entry he prepared regarding how municipalities regulate and apply design standards (see Attachment #3)
3. Rick Gosalvez, SV@Home, asked to be added to our project mailing list

Report Author & Contact Information

Jean Eisberg, Consultant Planner
(415) 841-3539
jean@lexingtonplanning.com

ARB⁶ Liaison & Contact Information

Jodie Gerhardt, AICP, Planning Manager
(650) 329-2575
jodie.gerhardt@cityofpaloalto.org

Attachments:

- Attachment A: Draft Objective Design Standards (PDF)
- Attachment B: Stakeholder Elaine Uang Comments (PDF)
- Attachment C: Stakeholder Ken Hayes Journal Post (PDF)

⁶ Emails may be sent directly to the ARB using the following address: arb@cityofpaloalto.org

Chapter 18.24 Context-Based Design Standards

WORKING DRAFT FOR ARB REVIEW

February 9, 2021

Preface

This document outlines the topics and potential design standards and guidelines for a new Chapter (18.24) of the Palo Alto Zoning Ordinance. This draft chapter represents a rewrite of the Palo Alto Context-Based Design Criteria and other parts of Title 18 as objective standards. The draft standards are based on the specific language of the existing design criteria, but reorganizes the content into subtopics described below. The objective standards project aims to transform subjective design criteria into reasonable, objective design standards that support the City’s priorities for design and development.

- 18.24.010 Purpose and Applicability 1
- 18.24.020 Public Realm/Sidewalk Character 2
- 18.24.030 Site Access 4
- 18.24.040 Building Orientation and Setbacks..... 5
- 18.24.050 Building Massing 12
- 18.24.060 Façade Design..... 16
- 18.24.070 Residential Entries 27
- 18.24.080 Open Space..... 30
- 18.24.090 Materials..... 32
- 18.24.100 Sustainability and Green Building Design..... 33

18.24.010 Purpose and Applicability

(A) Purpose

- (i) The purpose of the Context-Based Design Standards is to provide guidance for good design for all project types and objective design standards for multifamily and residential mixed-use development projects. Diagrams are provided for illustrative purposes only and are not intended to convey required architectural style.

(B) Applicability of Regulations

- (i) Within the following zones and combining districts, the intent statements apply to all project types (including non-residential projects), new construction, and renovations; objective design standards apply to new residential construction projects with three or more units (multi-family), and all residential mixed-use projects:
 - (a) 18.13: RM-20, RM-30, RM-40
 - (b) 18.16: CN, CC, CC(2), CS
 - (c) 18.18: CD-C, CD-S, CD-N
 - (d) 18.20: MOR, ROLM, ROLM(E), RP, RP(5), GM
 - (e) 18.30: AH or WH combining district
 - (f) 18.34: PTOD

Public art is subject to Chapter 16.61 and exempt from these requirements.

(C) Process and Alternative Compliance

Each section of this chapter includes an intent statement that gives guidance for all applicable projects, regardless of use.

Residential and mixed-use residential project applicants may choose to forgo one or more objective standards and instead meet the spirit of the relevant intent statements. Such requests will be reviewed and approved by the Director of Planning and Development Services or City Council, which may include a recommendation by the Architectural Review Board depending on the level of review required by Chapter 18.76.

Non-residential projects shall meet the intent statements, and are encouraged to meet objective design standards in this chapter. Compliance with the relevant intent statements will be reviewed and approved by the Director of Planning and Development Services or City Council, which may include a recommendation by the Architectural Review Board depending on the level of review required by Chapter 18.76.

(D) Definitions

In addition to definitions identified in Chapter 18.04, the following definitions are specific to this chapter.

- (i) **Primary Building Frontage:** The front lot line or frontage along the public right-of-way. In the case of a through-lot, the primary building frontage could be on either public right-of-way.
- (ii) **Primary Building Entry:** The entrance leading to a lobby and/or accessed from the primary building frontage.

- (iii) **Pedestrian Walkway:** A sidewalk or path that is publicly-accessible and connects from a public right-of-way to another public right-of-way or publicly accessible open space.
- (iv) **Façade Modulation:** A change in building plane, either a recess or a projection, that changes shape of the exterior massing of the building.

18.24.020 Public Realm/Sidewalk Character

(A) Intent

To create an attractive and safe public realm and sidewalk space for pedestrians and cyclists through the implementation of design, landscaping, and infrastructure. Publicly accessible spaces and sidewalks should:

- Design the transition between the public and private realm through the coordination of amenities and materials, such as accent paving, tree wells, lighting and street furniture (e.g., benches, bicycle racks, trash receptacles, and news racks).
- Complement or match accent paving to existing designs in the Downtown and California Avenue business district.
- Provide sidewalk widths that accommodate landscaping, street trees, furniture, and pedestrian amenities; create a pleasant, desirable place to walk; provide shade; and enable comfortable pedestrian passage.
- Provide amenities, such as parking and repair equipment, for micromobility, such as bicycles and scooters.

(B) Streetscape

(i) Sidewalk Widths

- (a) Public sidewalks abutting a development parcel in any commercial mixed-use district (CN, CS, CC, CC(2), CD-C, CD-S, CD-N, PTOD) shall have a minimum sidewalk width (curb to back of walk) of at least 10 feet. This standard may be met with a combination of pedestrian clear path and landscape and furniture strip (see Figure 1), as long as the pedestrian clear path is no less than 8 feet. If the existing public sidewalk does not meet the minimum standard, a publicly accessible extension of the sidewalk, with corresponding public access easement, shall be provided.
1. Notwithstanding the total dimension in subsection (a), the following streets/locations shall have a minimum sidewalk width as noted:
 - a. Park Boulevard (South of Caltrain to Ventura): TBD, per NVCAP
 - b. El Camino Real and San Antonio Road, west of Highway 101: 12 ft
- (b) Publicly accessible sidewalks or walkways connecting through a development parcel (e.g., on a through lot) shall have a minimum six-foot width.
- (c) Pedestrian walkways that are designed to provide access to bicycles shall have a minimum width of eight feet, with two feet of clear space on either side.

(ii) Street Trees

- (a) Sidewalks shall include at least one street tree, within six feet of the sidewalk, for every 30 feet of linear feet of sidewalk length. Rights of way under control of the

County of Santa Clara or State of California, supersede this requirement if they have conflicting regulations.

Figure 1: Illustrative Sidewalk Section and Description of Zones

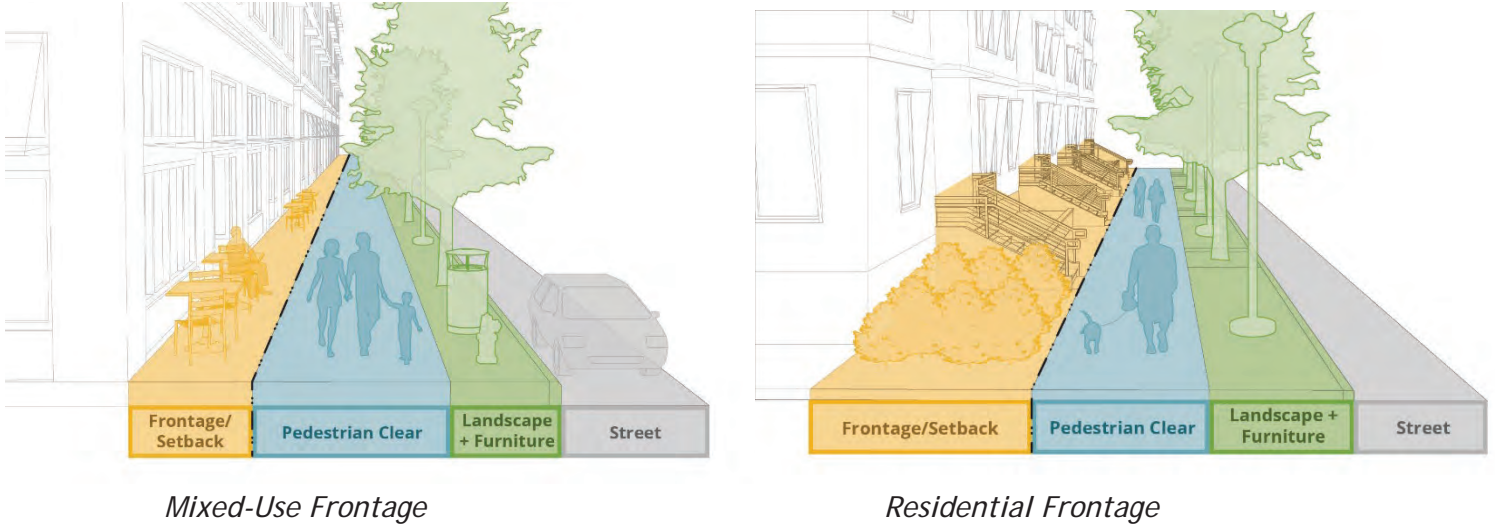

Frontage		Sidewalk		Street
Building Setback	Frontage Area	Pedestrian Clear Zone	Landscape/Furniture Zone	Vehicles/Bike Lanes
<p><i>Mixed-Use</i></p> <ul style="list-style-type: none"> • Sidewalk Dining • Outdoor Displays • Public Art • Seating • Trees/Planting 		<ul style="list-style-type: none"> • Sidewalk 	<ul style="list-style-type: none"> • Street Trees/Planting • Street Lighting • Seating • Bike Parking • Public Art • Outdoor Dining • Bus Shelters • Utilities (e.g., hydrants) 	<ul style="list-style-type: none"> • Street Parking • Bike Lanes • Drop-off Zones • Parklets • Bus Stops
<p><i>Residential</i></p> <ul style="list-style-type: none"> • Stoops • Porches • Front Yards • Trees/Planting 				

(iii) Accent Paving

(a) On University Avenue from Alma Street to Middlefield Road and on California Avenue from El Camino Real to Park Boulevard the following regulation applies:

1. Sidewalks and publicly accessible areas at intersections or fronting University Avenue or California Avenue shall match any existing accent paving design and materials, such as bricks or decorative glass.

(iv) Mobility Infrastructure

- (a) Micromobility infrastructure, such as locations to lock bicycles and scooters, shall be located within 30 feet of the primary building entry and/or a path leading to the primary building entry. This standard may be satisfied by existing infrastructure already located within 50 feet of the project site and located in the public right-of-way.
- (b) Primary building entries shall provide at least one seating area or bench within 30 feet of building entry and/or path leading to building entry. This standard may be satisfied by existing seating area or benches located in public right-of-way within 50 feet of the building entry. On arterials—except Downtown—seating areas or benches shall not be located between the sidewalk and curb. Arterial roadways are identified in Map T-5 of the Comprehensive Plan and do not include residential arterials.

18.24.030 Site Access**(A) Intent**

To provide facilities and accommodations for pedestrians, vehicles, cyclists, and transit users to safely and efficiently access and circulate both within individual sites and in the site's surrounding context. Site access should include the following elements:

- Site circulation and access that presents a clear hierarchy and connectivity pattern both within a project and to adjacent sidewalks and transit stops. This hierarchy should prioritize pedestrians, bikes, vehicles, and utility/loading access in the order listed. This hierarchy may provide separate access for vehicles and other modes, or demonstrate how all modes are accommodated in shared access points.
- Connections to side streets, open spaces, mews, alleys, and paseos
- Vehicle, loading and service access that is integrated into building and landscape design and located to prevent conflicts with pedestrians and cyclists, while also provided convenient access to building entries.

(B) Through-Lot Connections

- (i) Through lots located more than 300 feet from an intersecting street or pedestrian walkway shall provide a publicly accessible sidewalk or pedestrian walkway connecting the two streets.

(C) Building Entries

- (i) Entries to Primary Building Entries shall be located from a public right-of-way or, if not possible, a publicly accessible Pedestrian Walkway.

(D) Vehicle Access

- (i) Vehicle access shall be located on alleys or side streets where available.
- (ii) Except for driveway access, off-street parking, off-street vehicle loading, and vehicular circulation areas are prohibited between the building and the primary building frontage.

(E) Loading Docks and Service Areas

- (i) Loading and service areas shall be integrated into building and landscape design and located to minimize impact on the pedestrian experience as follows:
 - (a) Loading docks and service areas shall be located on facades other than the primary building frontage, on alleys, from parking areas, and/or at the rear or side of building if building includes these frontages. When only primary building frontage is available, loading docks and service areas shall be recessed a minimum five feet from the primary façade and shall be screened in accordance with Chapter 18.23.050.
 - (b) Loading dock and service areas located within setback areas shall be screened in accordance with Chapter 18.23.050 and separated from pedestrian access to the primary building entry to avoid impeding pedestrian movement and safety.

18.24.040 Building Orientation and Setbacks

(A) Intent

To create a coherent and active interface between private development and the public realm that contributes to the sense of place and structure of the neighborhood and enhances the public's experience. Site design that responds to the orientation of adjacent uses and creates opportunities for landscaping and usable open space. Buildings and site design should meet the following criteria:

- Buildings that create a contiguous street wall that are compatible with nearby buildings and land uses.
- Placement and orientation of doorways, windows, stoops, and landscape elements to create a direct relationship with the street.
- Ground floor residential units that have direct entry and presence on the street, and maintain privacy
- Transitional spaces and buffer areas between buildings, parcels, and sites through building setbacks that distinguish private and public spaces.
- Buildings that provide side and rear setbacks and/or upper story step backs to create a compatible relationship with adjacent lower density residential development.
- Landscaped or usable areas that contain open space or hardscaped areas.
- Optimized building orientation for heat gain, shading, daylighting, and natural ventilation and other forms of passive design.

(B) Building Orientation

(i) Treatment of Corner Buildings

(a) Corner buildings greater than 40 feet in height shall include one of the following special features:

- 1. Street wall shall be located at the minimum front yard setback or build-to line for a minimum aggregated length of 40 feet in length on both facades meeting at the corner and shall include one or more of the following building features:

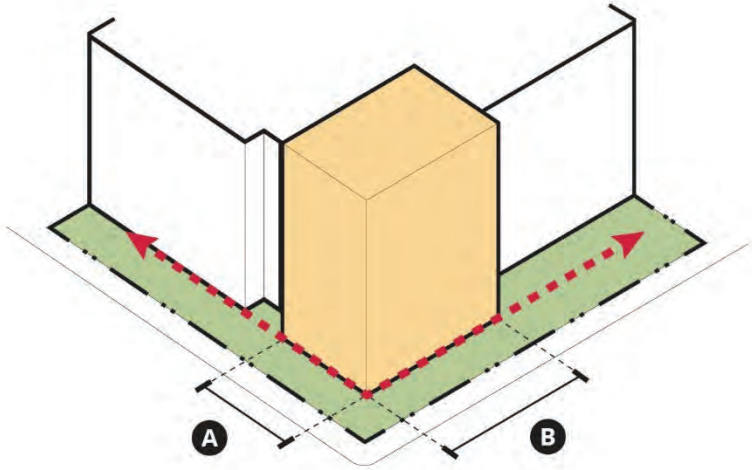



- A** Length 1 of corner element ■ Front yard setback area
- B** Length 2 of corner element <- - - - -> Build to line

where: **A** + **B** ≥ 40'

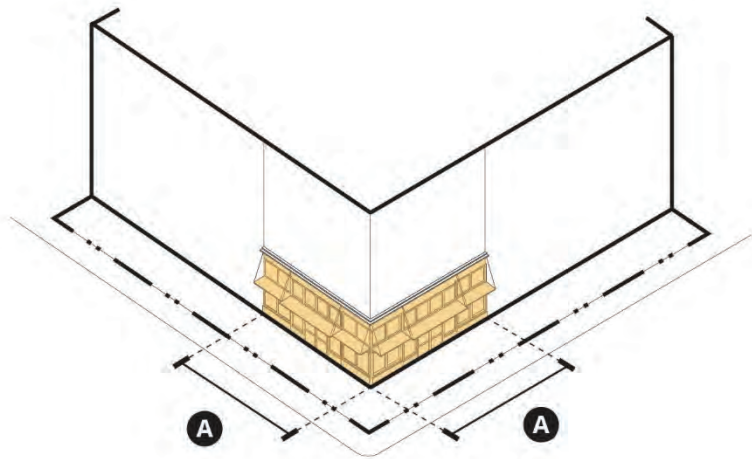

- a. An entry to ground floor retail or primary building entrance located within 20 feet of the corner of the building

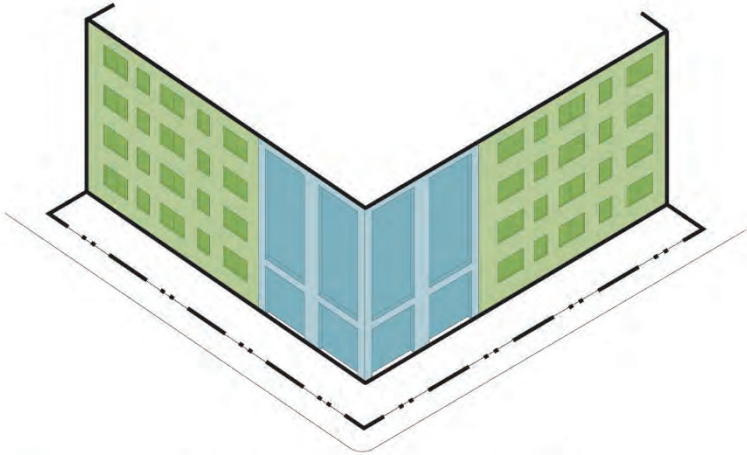

-  Corner entry to ground floor retail or primary building entrance
-  20' maximum distance from corner

- b. A different material application and fenestration pattern from the rest of the façade.



-  Corner element material or fenestration pattern
-  Remaining facade building material or fenestration pattern

c. A change in height of at least 4 feet greater or less than the height of the abutting façade.

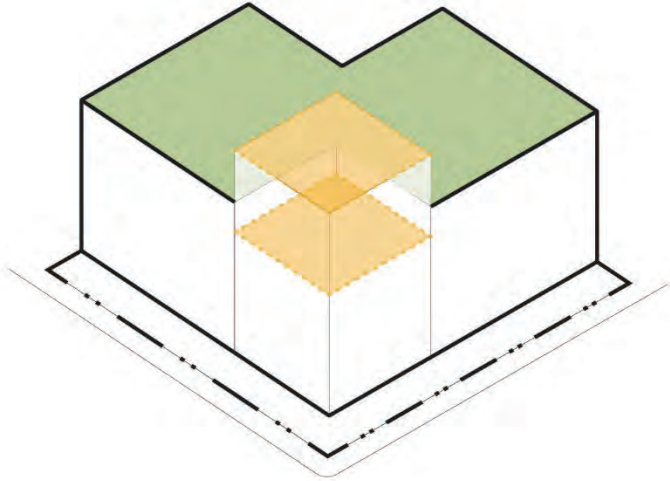

■ Corner element height $\leq 4'$ **or** $\geq 4'$ than abutting height
■ Building height of abutting facade

- 2. An open space with a minimum dimension of 20 feet and minimum area of 1,000 square feet. The open space shall be one of the following:
 - a. A publicly accessible open space/plaza
 - b. A space used for outdoor seating for public dining
 - c. A residential Common Open Space adjacent to a common interior space and not greater than three feet above adjacent sidewalk grade. Fences and railing shall be a minimum 50% transparent.

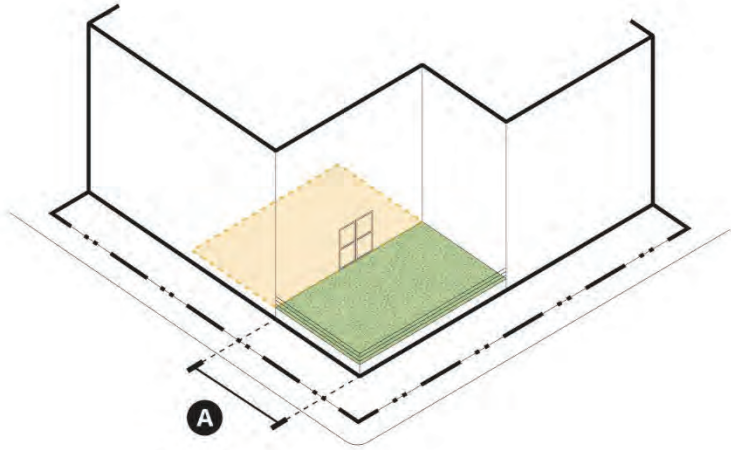

■ Common open space, minimum area $\geq 1,000$ sf
■ Adjacent indoor common open space
Ⓐ Minimum dimension $\geq 20'$

(ii) Primary Building Entry

- (a) The primary building entry shall meet one of the following standards:
1. Face a public right-of-way.
 2. Be visible from a public right-of-way through a forecourt or front porch that meets the following standards:
 - a. For residential buildings with fewer than seven units, building entry forecourts or front porches shall be a minimum area of 36 square feet and minimum dimension of six feet.
 - b. For commercial buildings or residential buildings with seven or more units, building entry forecourts or front porches shall be a minimum of 100 square feet and a minimum width of 8 feet.

(iii) Ground Floor Residential Units

- (a) The finished floor of ground floor residential units shall be within the minimum and maximum heights according to setback distance from back of walk identified in Figure 2. On sites with a cross slope greater than 2% along a building facade, the average height of the finished floor and back of walk shall be used.
- (b) Ground floor units with a setback greater than 15 feet shall have a minimum of one tree per 25 linear feet of façade located in the building set back.
- (c) Ground floor residential entries shall be setback a minimum of 10 feet from the back of sidewalk.
- (d) Where no minimum building set back is required, all residential units shall be set back a minimum 5 feet from back of walk.
- (e) A minimum of 80% of the ground floor residential units that face a public right-of-way or publicly accessible path, or open space shall have a unit entry with direct access to the sidewalk, path, or open space. (Senior units or other deed-restricted units for special populations are exempt)

Figure 2: Finished Floor range for ground floor residential units.

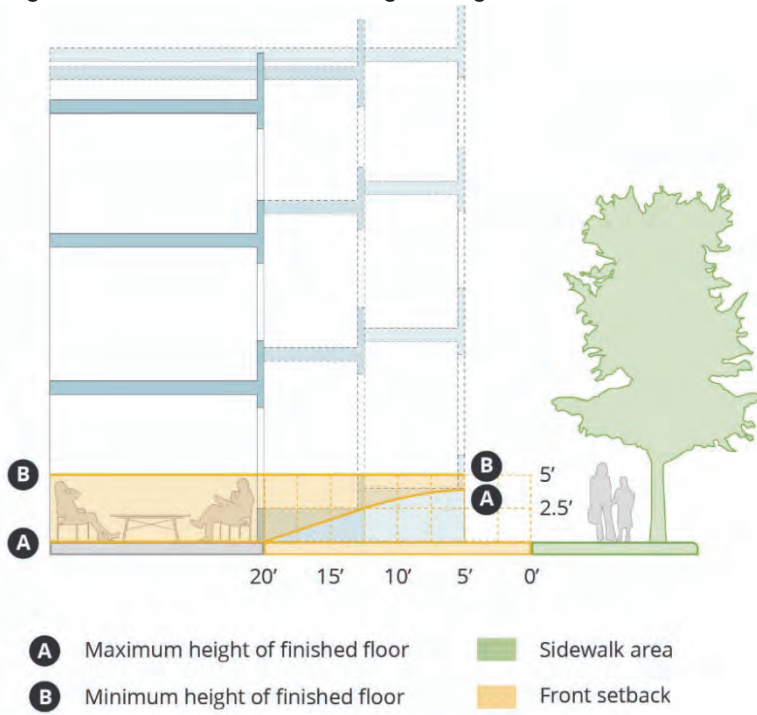

Example 1: Finished floor height greater than 4 feet above sidewalk grade.

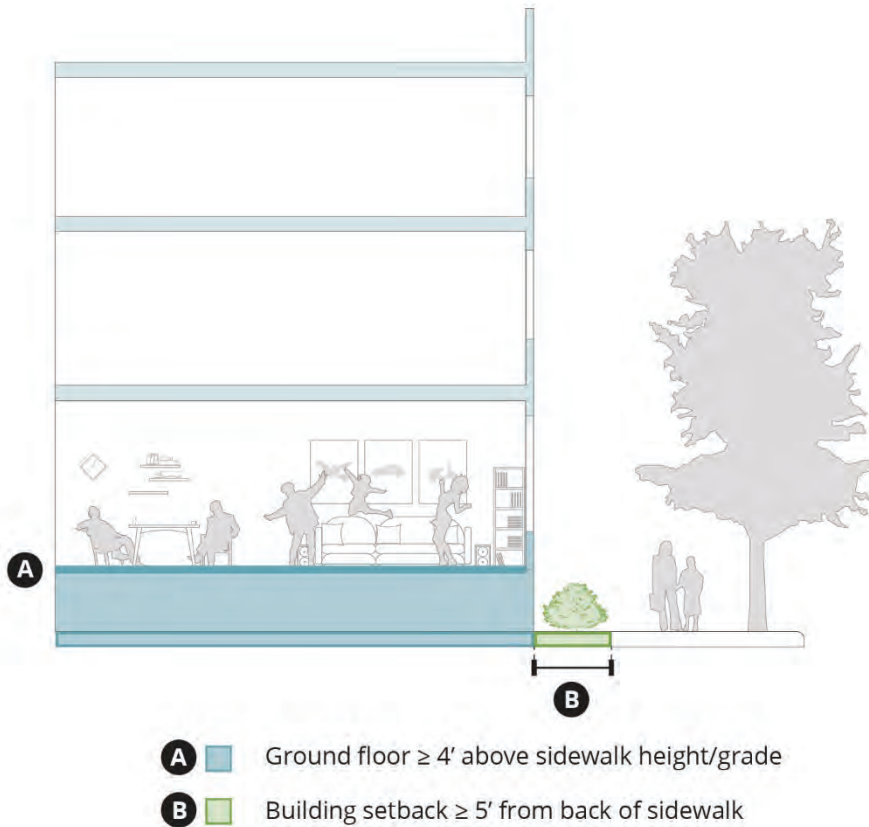

Example 2: Finished floor height in the middle of the range.



Example 3: Finished floor height at sidewalk grade.

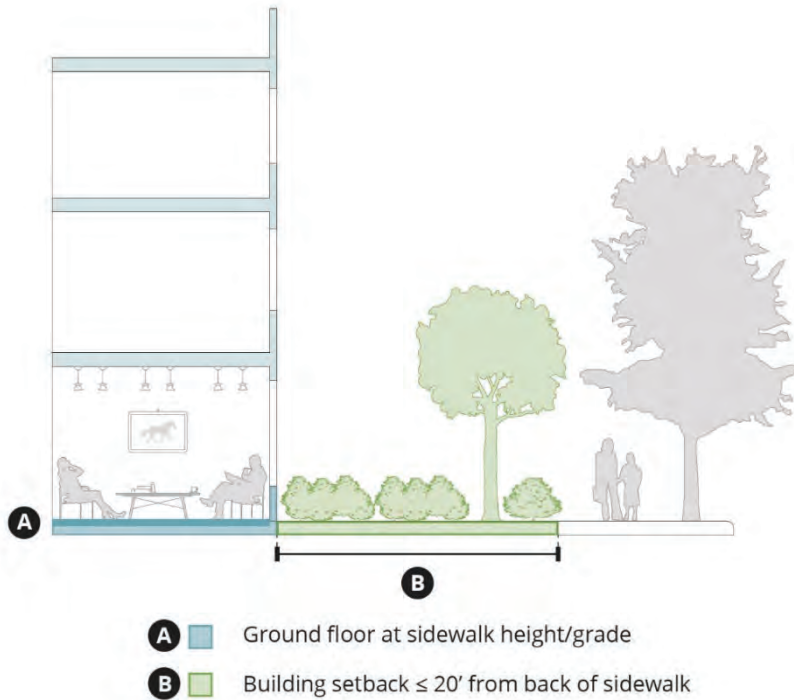

(C) Front Yard Setback Character

- (i) Required setbacks shall provide a hardscape and/or landscaped area to create a transition between public and private space. The following standards apply, based on intended use and exclusive of areas devoted to outdoor seating, front porches, door swing of building entries, and publicly accessible open space:
 - (a) Ground-floor retail or retail-like uses shall have a minimum of 10% of the required setback as landscaped area or planters.
 - (b) Ground-floor residential uses shall have a minimum of 60% of the required setback be landscaped area

18.24.050 Building Massing

(A) Intent

To create buildings that are compatible with and enhance the surrounding area through the consideration of building scale, massing, and bulk. Massing should create a human-scale environment that is of high aesthetic quality and accommodates a variety of uses and design features. Building massing should include elements that:

- Break down large building facades and massing to create a human-scaled building that enhances the context of the site
- Are consistent in scale, mass and character to adjacent land uses and land use designations
- Reinforce the definition and importance of the street
- Provide rooflines and massing that emphasize and accentuate significant elements of the building such as entries, bays, and balconies, and shading elements where appropriate.
- Provide harmonious transitions between adjacent properties

(B) Contextual Massing**(i) Upper Floor Step Backs**

- (a) When the height of the subject building is more than 20 feet above the average height (i.e., average of low and high roof elevations) of an adjacent building, an upper floor step back shall start within 2 vertical feet of the height of the adjacent building. The step back shall be a minimum depth of six feet along the primary building frontage, and the step shall occur for a minimum of 70% of the façade length.
- (b) Notwithstanding, subsection (a), when adjacent to a single-story building, the upper floor step back shall occur between 33 and 37 feet in height.

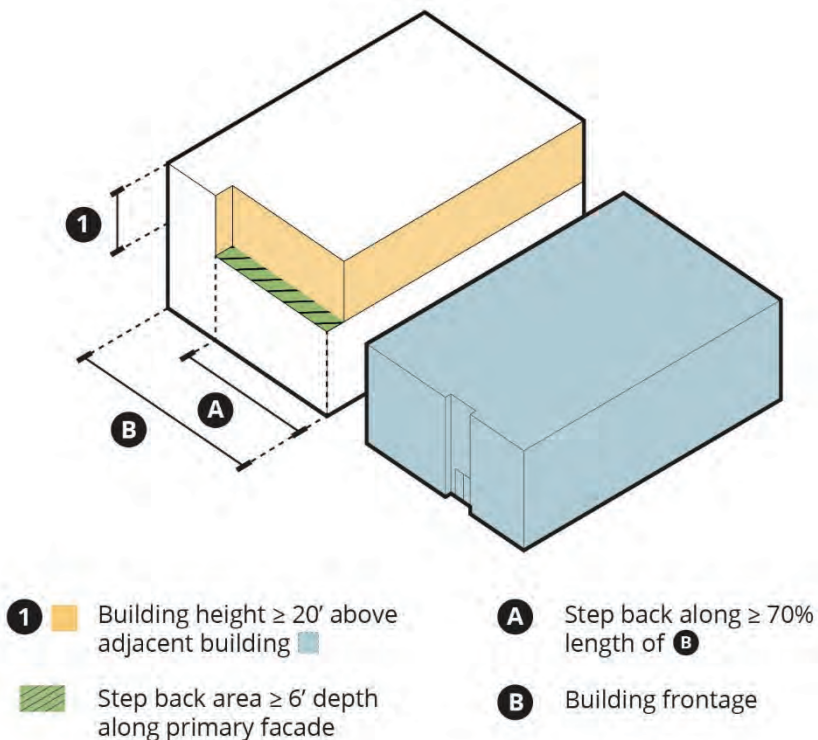
**(ii) Transition to Lower Density Building Types**

- (a) When a building abuts a side and/or rear property line with a RE, RMD, R-1, or R-2 zoned parcel or a village residential or existing single-family residential use, the building shall break down the abutting façade by meeting all of the following standards:
1. A landscape screen that includes a row of trees with a minimum 1 tree per 30 linear feet and continuous shrubbery planting. This screening plant material shall be a minimum 72 inches (6 feet) in height when planted. Required trees shall be minimum 36" box size.

2. A minimum façade break of six feet in width and six feet in depth for every 36 to 40 feet of façade length.

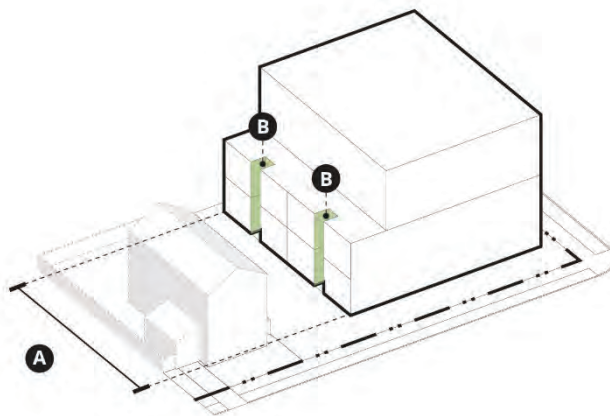

- A** Building facade \geq 40' **B** 6' wide, 6' deep break

3. Within 40 feet of an abutting structure, no more than 15% of the interior façade area shall be windows or other glazing. Additional windows are allowed if they are fixed and fully obscured, as this will allow light but maintain privacy.

(C) Maximum Façade Length

(i) Significant Breaks

(a) For portions of a building facade facing a public street, right-of-way, or publicly accessible path, any building greater than 25 feet in height and 70 feet in length shall not have a continuous façade plane greater than 70% of the façade length without an upper floor modulation, which can include bay windows. Upper floor façade modulations shall be a minimum 4 feet in depth, which can be a recess or a projection.

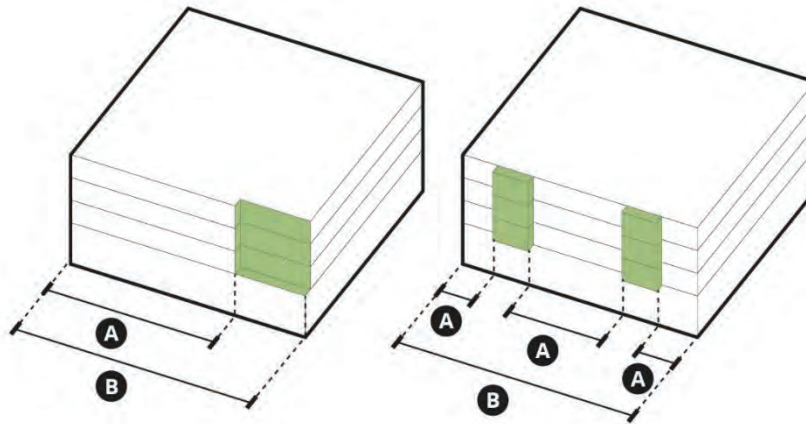

- A** Non-continuous building facade \leq 70% length of **B**
- B** Building length
- Upper floor above 25' with modulation \geq 4' in depth

(b) Buildings greater than 100 feet in length, which face a public street, right-of-way, or publicly accessible path, shall have at least one vertical façade break with a minimum area greater than 600 square feet and a width greater than or equal to two times the depth.

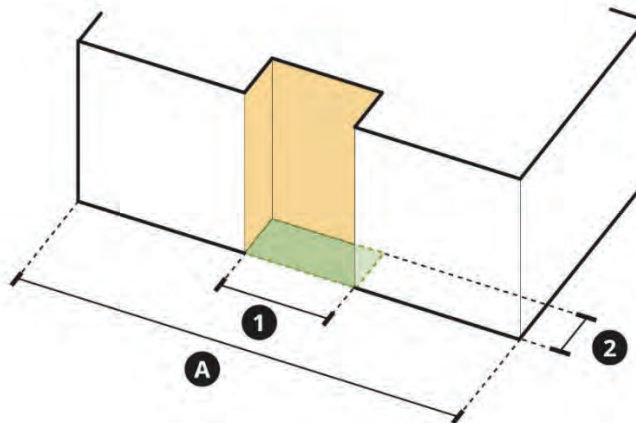

- A** Building facade \geq 100'
- Vertical façade break
- Façade break area \geq 600 sf
- 1** Façade break width \geq (2 * **2**)
- 2** Façade break depth

(D) Special Conditions

(i) Railroad Frontages

- (a) All parcels with lot lines abutting railroad rights-of-way shall meet the following standards on the railroad-abutting facade:
1. A minimum facade break of at least 10 feet in width and six feet in depth for every 60 feet of façade length.
 2. For portion of a building 20 feet or greater in height, a maximum continuous façade length shall not exceed 60 feet.

18.24.060 Façade Design

(A) Intent

To create cohesive and well-crafted building facades with human-scaled details that incorporate textures, colors, and other details that are compatible with and enhance the surrounding area. Facades should include the following elements:

- Human-scaled detail, articulation, and craftsmanship
- Quality of construction, craftsmanship, and design to create long lasting buildings
- Expression of a human-scaled façade rhythm and pattern that reflects the building's use
- Fenestration that enhances the architectural character of the building
- Defined building entry that is proportional to the building and number of people served
- Articulation of the building shall break down the scale of the building via building modulation, façade articulation, and variation of fenestration and material patterns.

(B) Application

- (i) All facades shall meet all the required design standards and guidelines to ensure the same level of care and integrity throughout the building design.
- (ii) Façade sidewalls located along a zero-lot line where, at time of approval are not visible from a right-of-way, are exempt.
- (iii) Façade sidewalls located along a zero-lot line, where at time of approval are visible from a right-of-way, shall continue color, material, and pattern of the main façade.

(C) Human Scaled Architecture

(i) Base/Middle/Top

- (a) Buildings three stories or taller, on lots wider than 50 feet, shall be designed to differentiate a defined base or ground floor, a middle or body, and a top, cornice, or parapet cap. Buildings two stories or less shall include a defined base and top. Each of these elements shall be distinguished from one another through use of two or more of the following four techniques:

1. *Variation in building modulation (minimum of one, if option selected)*

- a. Horizontal shifts. Changes in floor plates that protrude and/or recess with a minimum dimension of two feet from the primary facade.

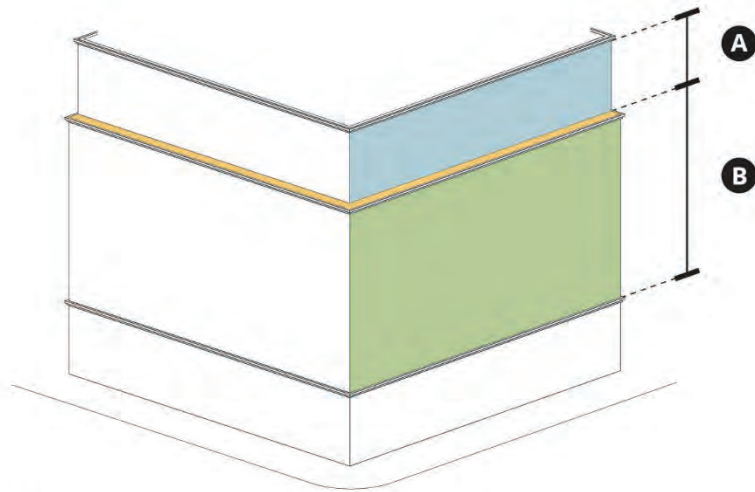

A Horizontal shift from primary facade > 2' deep
B Primary Facade
Recessed Facade

- b. Upper floor step backs. A horizontal step back of upper-floor façades with a minimum five-foot step back from the primary façade for a minimum of 80% of the length of the façade.

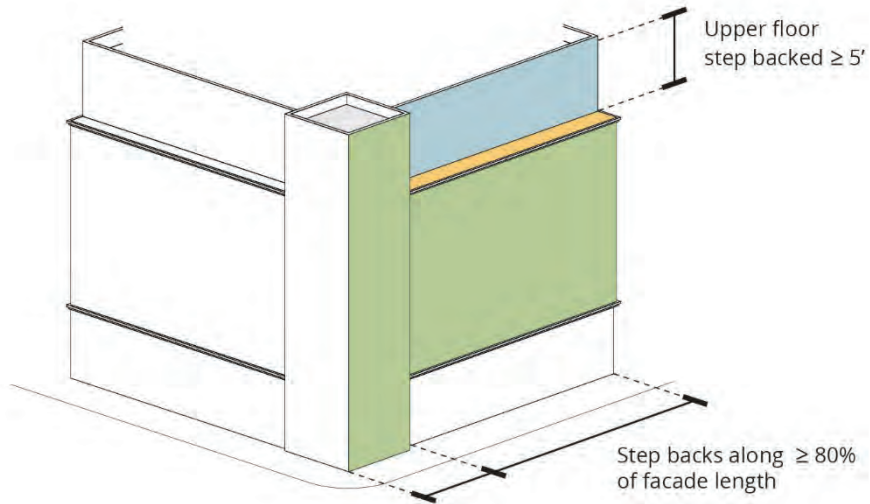

- c. Ground floor step back. A horizontal shift of the ground floor facade with a minimum depth of two feet for a minimum 80% of the length of the façade. Ground floor step backs shall not exceed the maximum setback requirements, where stated.

2. *Variation in facade articulation (minimum of one, if option selected)*

- a. Horizontal and/or vertical recesses or projections such as a pattern of recessed grouping of windows, recessed panels, bay windows or similar strategies as approved by the Director of Planning and Development Services. The recess shall be a minimum four inches in depth.

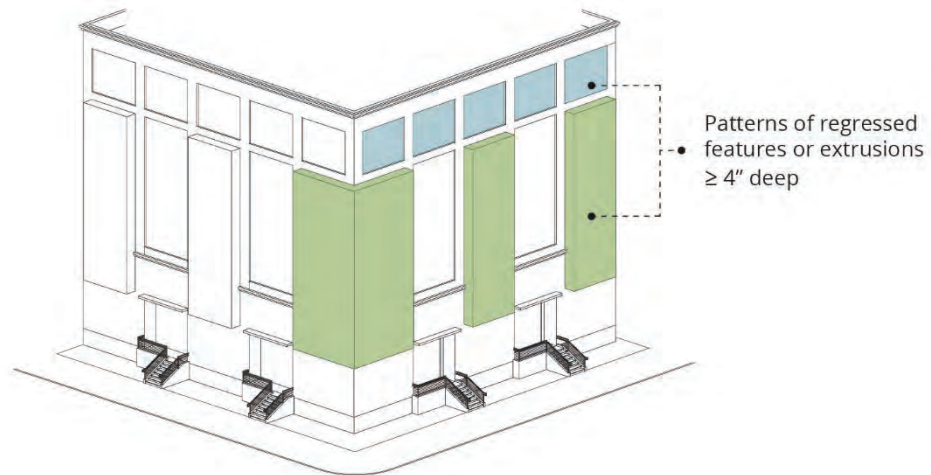

- b. Horizontal and/or vertical projections such as shading and weather protection devices, decorative architectural details, or similar strategies as approved by the Director. Projections shall be a minimum four inches in depth.



- c. Datum lines that continue the length of the building, such as parapets or cornices, with a minimum four inches in height or a minimum two inches in depth and include a change in material;

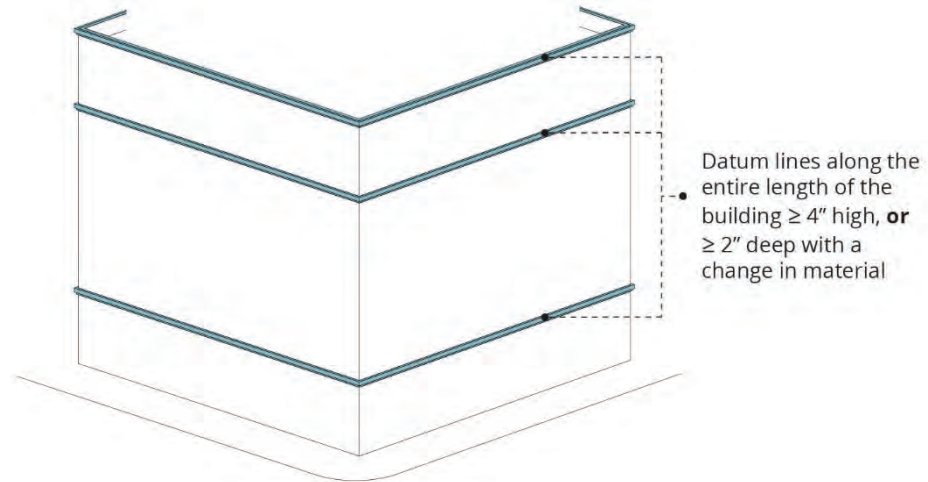

3. *Variation in fenestration size, proportions, pattern, and depth or projection.*



4. *Variation in two of the following: façade material, material size, texture and pattern, or color.*

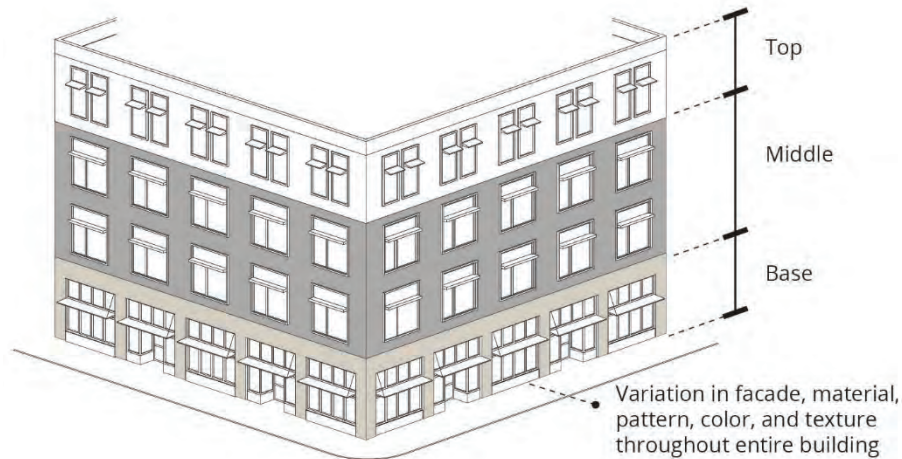

(ii) Façade Composition

- (a) Building facades shall use a variety of strategies including building modulation, fenestration, and façade articulation to create visual interest and express a variety of scales through a variety of strategies. All facades shall include a minimum of two of the following façade articulation strategies to create visual interest:
1. Vertical and horizontal recesses such as a pattern of recessed grouping of windows, recessed panels, or similar strategies as approved by the Director of Planning and Development Services. The recess shall be a minimum four inches in depth.
 2. Vertical and horizontal projections such as shading and weather protection devices, decorative architectural details, or similar strategies as approved by the Director of Planning and Development Services. Projections shall be a minimum four inches in depth.
 3. Datum lines that continue the length of the building, such as cornices, with a minimum four inches in depth, or a minimum two inches in depth and include a change in material;
 4. Balconies, habitable projections, or Juliet balconies (every 20 to 40 feet) with a minimum four inches in depth;
 5. Screening devices such as lattices, louvers, shading devices, perforated metal screens, or similar strategies as approved by the Director of Planning and Development Services; or
 6. Use of fine-grained building materials, such as brick or wood shingles, not to exceed eight inches in either height or width.

(iii)Compatible Rhythm and Pattern

(a) Residential or residential mixed-use buildings shall express a vertical rhythm and pattern that reflects the size and scale of a housing unit and/or individual rooms and spaces. This may be achieved with building modulation to create vertically oriented facades (height greater than the width of the façade), façade articulation and fenestration repetitive vertically oriented patterns. The following standards apply:

1. For facades less than 100 feet in length, the façade shall have vertically oriented patterns of vertical recesses or projects, façade articulation, and/or fenestration.

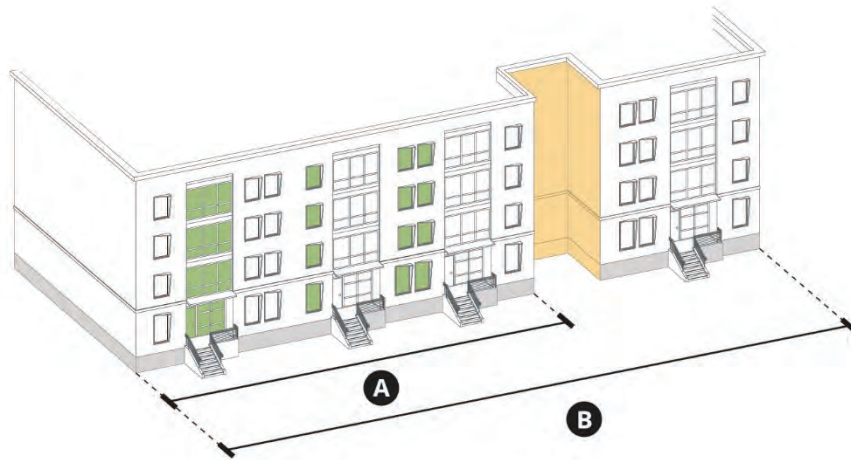

- A** Facade length \leq 100'
- B** Building length \geq 100'
- Vertically oriented patterns
- Major break for buildings \geq 100' long

2. For continuous facades greater than 100 feet in length, the façade shall include a vertical recess or projection with a minimum four feet wide and two feet deep vertical shift modulation to establish a rhythm between 20 to 50 feet in width for housing units or 12 to 16 feet in width for individual rooms and spaces.

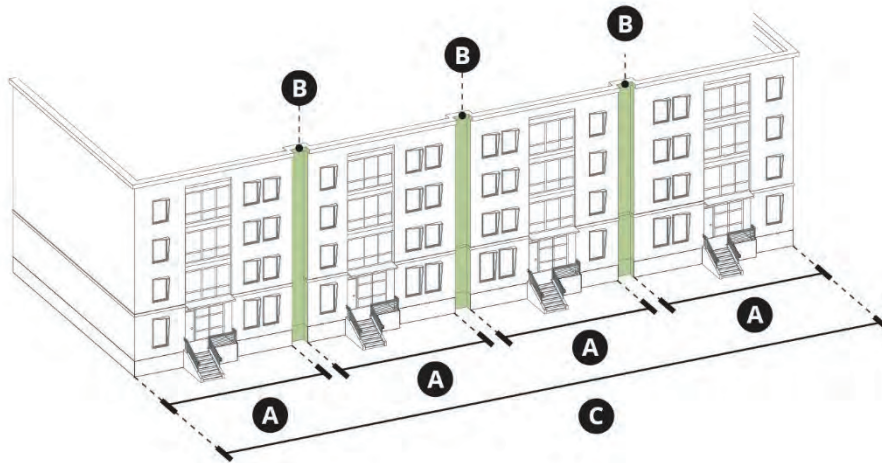

- A** 20' - 50' horizontal increment
- B** 4' wide, 2' deep vertical recesses
- C** Building length \geq 100'
- Vertically oriented patterns



- A** 12' - 16' wide vertical recess/projections
- B** Building length \geq 100'
- Vertically oriented patterns

(b) Residential mixed-use shall express a vertical rhythm and pattern and differentiate residential and non-residential building components by using one of the following options:

1. Facades shall use vertical patterns of building modulation, façade articulation, and fenestration;



Vertical patterns along building facade

2. Facades that use horizontal articulation and fenestration patterns shall use a vertical massing strategy with a minimum four feet wide and two feet deep vertical shift in modulation at least once every 50 feet of façade length.

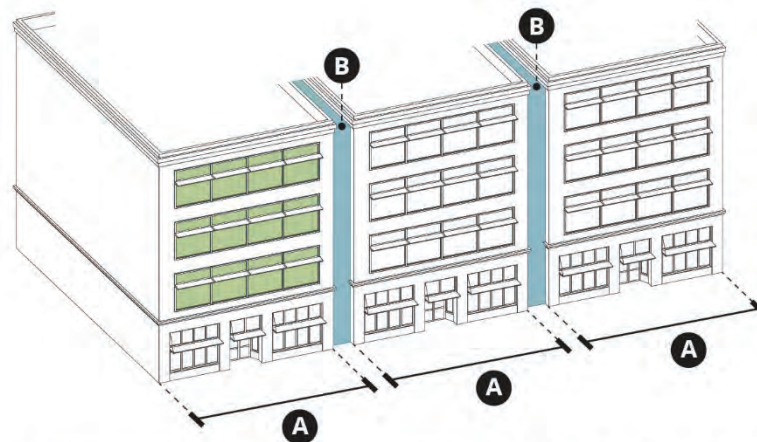

- A** Vertical modulation \geq 50' of building length
- B** 4' wide, 2' deep vertical recesses

Horizontally oriented patterns along building facade

- (c) Storefront uses shall express a vertical rhythm not to exceed 30 to 50 feet in width.

(iv) Emphasize Building Elements and Massing

(a) Building Entries Within Façade Design

1. Primary building entries shall be scaled proportionally to the number of people served (amount of floor-area or number of units accessed). Building entries inclusive of doorway and facade plane shall meet the following minimum dimensions:
 - a. Individual residential entries: five feet in width
 - b. Shared residential entry, such as mixed-use buildings: 8 feet in width
 - c. Commercial building entry: 20 feet in width
 - d. Storefront entry: six feet in width
 2. Primary building entries (not inclusive of individual residential entries) shall include a façade modulation that includes at least one of the following:
 - a. A recess or projection from the primary façade plane with a minimum depth of two feet.
- (b) Primary entries shall include weather protection that is a minimum 4 feet wide and 4 feet deep by recessing the entry, providing an awning or using a combination of these methods.

(D) Ground Floor Character

(i) Storefront/Retail Ground Floors

- (a) Ground floor height shall be a minimum 14 feet floor-to-floor or shall maintain a 2nd floor datum line of an abutting building-
- (b) Transparency shall include a minimum 60 percent transparent glazing between 2 and 10 feet in height from sidewalk, providing unobstructed views into the commercial space.
- (c) Bulkheads and solid base walls: If provided, shall measure between 12 and 30 inches from finished grade
- (d) Primary entries shall include weather protection that is a minimum 6 feet wide and 4 feet deep by recessing the entry, providing an awning or using a combination of these methods.
- (e) Awnings, canopies and weather protection:
 1. When transom windows are above display windows, awnings, canopies and similar weather protection elements shall be installed between transom and display windows. These elements should allow for light to enter the storefront through the transom windows and allow the weather protection feature to shade the display window.
 2. Awnings may be fixed or retractable.

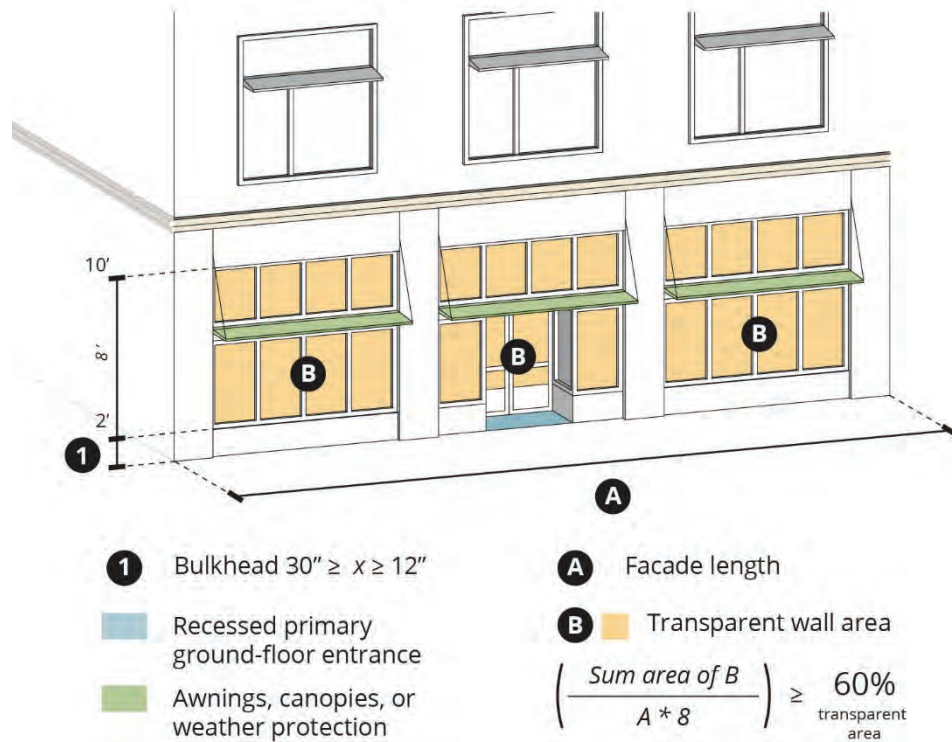

(ii) Other Non-residential Ground Floors

- (a) Ground floor height shall be a minimum 14 feet floor-to-floor or shall match the 2nd floor datum line of an abutting building.
- (b) Transparency shall include a minimum 50 percent transparent glazing between 4 and 10 feet in height from sidewalk or terrace grade.
- (c) Primary entries shall include weather protection that is a minimum 8 feet wide and 6 feet deep by recessing the entry, providing an awning or using a combination of these methods.

(iii) Residential Ground Floors

- (a) Finished Floor Height: Units on ground floors shall have a finished floor height at a minimum two feet above average back of sidewalk height for the associated façade.

(E) Parking/Loading/Utilities

- (i) Entry Size: No more than 25% of the site frontage facing a street should be devoted to garage openings, carports, surface parking, loading entries, or utilities access (on sites with less than 100 feet of frontage, no more than 25 feet)
- (ii) Above grade structured parking levels facing a public right-of-way or publicly accessible open space/path shall be lined with commercial or habitable uses with a minimum depth of 20 feet.
- (iii) Partially sub-grade parking shall not exceed five feet in height above abutting grade at back of sidewalk.
 - (a) Partially sub-grade parking shall be screened with continuous landscaping and shrubbery with minimum height of 3 feet and be within 10 feet of the sub-grade parking.

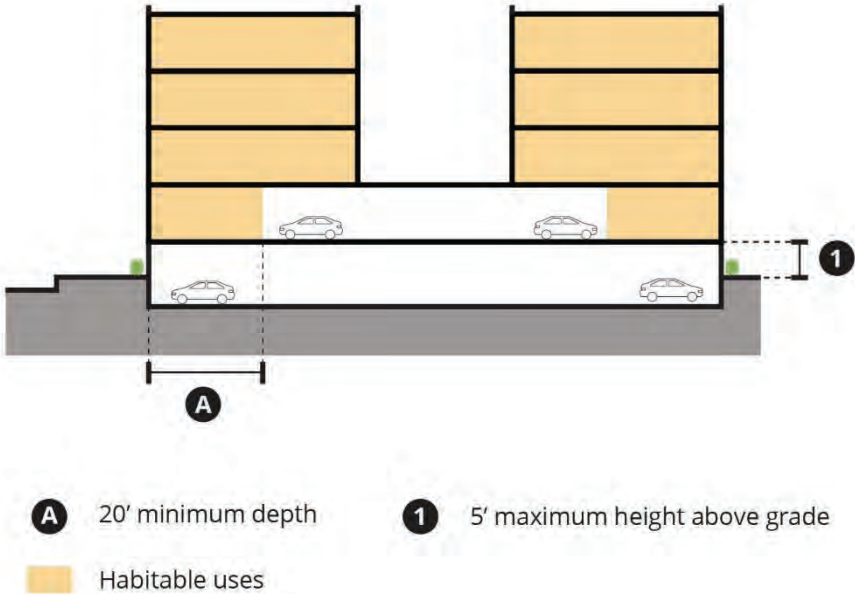

18.24.070 Residential Entries

(A) Intent

Private entries into ground floor residential units shall be designed to provide:

- human-scaled detailing
- enhanced pedestrian experience
- transition between public and private space
- spaces for residents to gather and spend time outdoors
- resident privacy

(B) Ground floor unit entries

(i) Where ground floor residential unit entries are required, one or more of the following entry types shall be provided:

(a) Stoop:

1. Stoops shall provide entry access for a maximum of two units; and
2. Stoop entry landings shall be a minimum 5 feet in depth; and
3. The maximum stoop height from the back of sidewalk grade shall be 5 feet.



(b) Porch:

1. Porches shall provide entry access for a maximum of one unit; and
2. Porches shall be large enough so a 6-foot by 6-foot square can fit inside of a porch for each unit; and
3. The maximum porch floor height from the back of sidewalk grade shall be 5 feet.



(c) **Patio Entry**

1. Patio entries may serve up to two units; and
2. Patios shall be large enough so a 9-foot by 9-foot square can fit inside of the patio for each unit; and
3. The Patio shall include at least one of the following features to define the transition between public and private space:
 - a. A row of shrubs not exceeding 42 inches in height located between the sidewalk and the patio that assists with defining the edge between public and private space. Shrubs shall be at least one gallon in size and be planted a maximum of three feet on center; or
 - b. A fence not to exceed 30 inches in height located between the sidewalk and the patio that assists with defining the edge between public and private space, with a gate or fence opening to provide access to the pedestrian route between the pedestrian way and the front door; or
 - c. A metal, wood or stone wall not to exceed 30 inches in height located between the sidewalk and the patio that assists with defining the edge between public and private space with a gate or wall opening to provide access to the pedestrian route between the pedestrian way and the front door. A minimum 18-inch landscape strip shall be located between the wall and the abutting pedestrian way and entirely landscaped with ground cover, shrubs or other landscape living plant material.



(d) Terrace:

1. A Terrace may serve multiple unit entries; and
2. The maximum Terrace height shall be 30 inches above the grade of the back of the adjacent sidewalk or accessway; and
3. Walls, fences and hedges on Terraces shall be a maximum of 42 inches tall and have a minimum transparency of 40 percent.

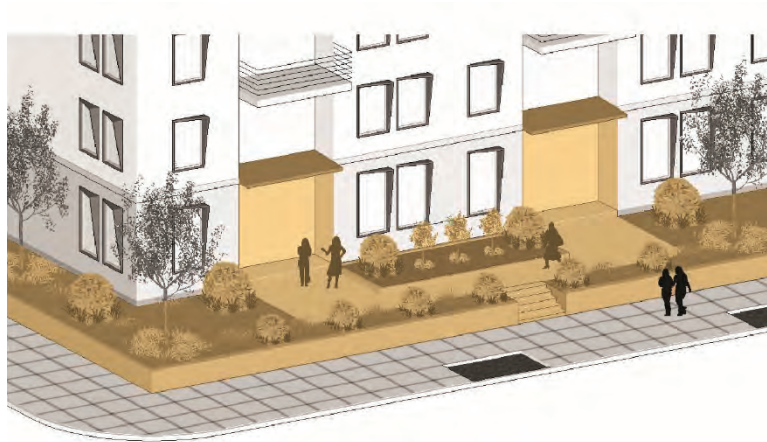
**(e) Frontage Court:**

1. A Frontage Court may serve multiple unit entries; and
2. The minimum Frontage Court width along a primary frontage shall be 25 feet; and
3. The maximum Frontage Court width along a primary frontage shall be 50 percent of the facade length or 80 feet, whichever is less; and
4. The minimum Frontage Court depth shall be 25 feet; and
5. The maximum Frontage Court depth shall be 50 feet or a ratio not to exceed 2:1 depth to width.



18.24.080 Open Space

(A) Intent

To ensure that residents and visitors have access to usable open space and common facilities that provide recreational opportunities, promote a healthy environment, and enhance the experience of living in Palo Alto. Common and private open spaces should include the following characteristics:

- Be integrated into the site access and building circulation strategy
- Be generous in dimension to provide usable space
- Provide landscape elements that will support the health of the plants and enhance the character of place
- Promote public health
- Be located to provide easy access to private and common building areas, and balance privacy and noise impacts to neighboring uses
- Promote sustainable practices and opportunities for green infrastructure
- Promote community safety through eyes on the street

(B) Private Open Space

- (i) If Private Open Spaces is provided, it shall meet the following standards:
- (a) Floor area shall include a clear space with a minimum dimension of a circle with a six-foot diameter.
 - (b) Minimum clear height dimension of 8'-6" feet
 - (c) Be accessed directly from a residential unit
 - (d) Balconies shall not be located within the daylight plane
 - (e) Notwithstanding subsection (a), ground floor patios shall meet the following minimum requirements:
 1. RM-20 and RM-30 districts: Minimum 100 square feet of area, the least dimension of which is eight feet for at least 75% of the area
 2. RM-40 districts: Minimum 80 square feet of area, the least dimension of which is six feet for at least 75% of the area
 3. Street facing private open space on the ground floor shall meet the finished floor height for ground floor residential standards in section 18.24.040(iii)(a)

(C) Common Open Space

- (i) If Common Open Space is provided, it shall meet the following standards:
1. Minimum size of 200 square feet
 2. Floor area shall include a space with a minimum dimension of a circle with a 10-foot diameter.
 3. A minimum of 60% of the area shall be open to the sky and free of permanent weather protection or encroachments. Trellises and similar open-air features are permitted.

4. Notwithstanding subsection (1), courtyards enclosed on four sides shall have a minimum dimension of 40 feet and have a minimum courtyard width to building height ratio of 1:1.25

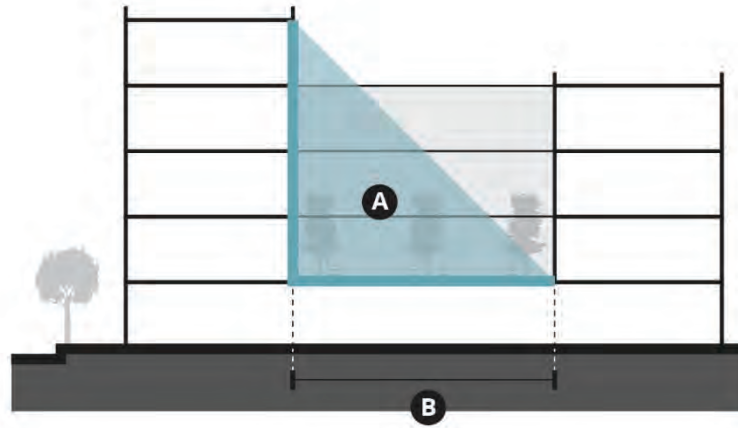

- A** Minimum courtyard width to building height ratio of 1:1.25 **B** 40' minimum dimension

5. Include places to sit
6. A minimum 20% of landscaping
7. Soil Depth: Planting in above grade courtyards shall have a minimum soil depth of 12 inches for ground cover, 20 inches for shrubs, and 36 inches for trees.
8. Rooftop Open Space:
- In order to qualify as usable open space, a rooftop garden shall meet the requirements set forth in Section 18.40.230.
 - Rooftop open spaces may fulfill usable open space requirements in the following districts:
 - CD-C sites that do not abut a single- or two-family residential use or zoning district, rooftop gardens may qualify as usable open space and may count as up to 75% of the required usable open space for the residential component of a project.
 - For CN and CS sites on El Camino Real and CC(2) sites that do not abut a single- or two-family residential use or zoning district, rooftop gardens may qualify as usable open space and may count as up to 60% of the required usable open space for the residential component of a project.

18.24.090 Materials

(A) Intent

To promote the use of high quality, durable, sustainable, and attractive materials that exhibit a sense of permanence and contribute to the aesthetic quality of the development and to the urban design fabric of the community.

(B) Façade Materials

- (i) Buildings shall utilize primary materials for no less than 65 percent of each building facade.
- (ii) Secondary materials are prohibited as primary cladding on building facades and shall not be allowed on more than 35 percent of each building facade.
- (iii) Accent materials are permitted on no greater than 5 percent of each facade as trims or accents (e.g., flashing, projecting features, ornamentation, etc.).
- (iv) Buildings 30 feet and shorter, measured from grade plane to eave or top of parapet, whichever is higher, with elevations 50 feet or narrower may utilize any secondary material as a primary material.
- (v) Primary, Secondary and Accent materials are allowed or prohibited as noted in Table 1.

Table 1: Allowable and Prohibited Materials

<i>Material</i>	<i>Usage</i>
Brick (full dimensional)	P
Stone/masonry	P
Stucco	P
Glass (transparent, spandrel)	P
Finished wood, wood veneer, engineered wood, and wood siding	P
Factory or naturally finished flat, profiled, fluted, or ribbed metal panels	P
Fiber reinforced cement siding and panels	P
Terracotta	P
Concrete (poured in place or precast)	S
Concrete blocks with integral color (ground, polished, or glazed finishes)	S
Concrete blocks with integral color (split face finish)	S
Ceramic tile	S
Standing seam metal	S
Glass block	A
Corrugated metal	A

<i>Material</i>	<i>Usage</i>
Vegetated wall panels or trellises	A
Vinyl siding	N
T-111 Plywood	N
Exterior Insulation Finishing System (EIFS)	N
Plastic or vinyl fencing	N
Chain link fencing	N

P = Primary or Secondary material

S = Secondary material only

A = Accent material

N = Prohibited material or fencing type

18.24.100 Sustainability and Green Building Design

(A) Intent

To incorporate sustainability, green building, and environmental considerations into the project design and construction. Green building design aims for compatibility with the local environment: to protect, respect and benefit from it. In general, sustainable buildings are energy efficient, water conserving, durable and nontoxic, with high-quality spaces and high recycled content materials. The following considerations should be included in site and building design:

- Optimize building orientation for heat gain, shading, daylighting, and natural ventilation, including operable windows
- Design landscaping to create comfortable micro-climates and reduce heat island effects
- Maximize onsite stormwater management through landscaping and permeable pavement
- Use sustainable building materials
- Design lighting, plumbing and equipment for efficient energy use
- Create healthy indoor environments
- Use creativity and innovation to build more sustainable environments. One example is establishing gardens with edible fruits, vegetables or other plants to satisfy a portion of project open space requirements

(B) Standards

See Chapter 16.14: California Green Building Standards additional requirements for green building and sustainable design. Notwithstanding Section 18.24.010(c), these regulations may not be modified through alternative compliance.

Chapter 18.24 Context-Based Design Standards

18.24.010 Purpose and Applicability

(A) Purpose

- (i) The purpose of the Context-Based Design Standards is to provide design guidance and objective design standards development projects.

(B) Applicability of regulations

- (i) Within the following zones, the intent statements apply to all project types, new construction, and renovation; design standards apply to new construction: 1

- | | |
|--|--|
| <ul style="list-style-type: none"> (a) RM-20, RM-30, RM-40 (b) CN, CS, CD, CC (c) PTOD (d) MOR, ROLM, RP (e) PC | <p>Cite relevant chapters:</p> <ul style="list-style-type: none"> a) 18.13 Multiple Family Residential b) 18.16 CN,CC,CS & 18.18 CD c) 18.34 PTOD d) MOR, ROLM, RP e) PC - what about PHZ? |
|--|--|

Public art in residential and residential mixed-use projects is subject to Chapter 16.61 and exempt from these requirements.

(C) Alternative compliance

Each section of this chapter includes an intent statement that gives guidance for all applicable projects, 2 regardless of use.

Residential and mixed-use residential projects may choose to forgo one or more objective standards and 3 instead meet the spirit of the relevant intent statements, as determined by the Director or the Architectural Review Board, depending on the level of review required by Chapter 18.75.

Commercial-only projects or other non-residential projects should meet relevant standards; they are not required to adhere irrelevant standards related to residential uses. Depending on the level of review required by Chapter 18.75, the Director or the Architectural Review Board will determine compliance with the relevant intent statements.

(D) Definitions

In addition to definitions identified in Chapter 18.04, the following definitions are specific to this chapter.

- (i) **Primary Building Frontage:** The front lot line or frontage along the public right-of-way. In the case of a through-lot, the primary building frontage could be on either public right-of-way.
- (ii) **Primary Building Entry:** The entrance leading to a lobby and/or accessed from the primary building frontage.
- (iii) **Pedestrian Walkway:** A sidewalk or path that is publicly-accessible and connects from a public right-of-way to another public right-of-way or publicly accessible open space.
- (iv) **Façade Modulation:** A change in building plane, either a recess or a projection, that changes shape of the interior space.

Summary of Comments on Agenda - Thursday, November 19, 2020

Page: 2

☰ Number: 1 Author: elaine Subject: Text Box Date: 1/18/2021 8:51:45 AM

Cite relevant chapters: a) 18.13 Multiple Family Residential b) 18.16 CN,CC,CS & 18.18 CDc) 18.34 PTOD d) MOR, ROLM, RPe) PC - what about PHZ?

📄 Number: 2 Author: elaine Subject: Highlight Date: 12/5/2020 1:26:02 PM
regardless of use.

📄 Number: 3 Author: elaine Subject: Highlight Date: 12/5/2020 1:38:19 PM
d instead meet the spirit of the relevant intent statements

18.24.020 Public Realm/Sidewalk Character

(A) Intent

¹ To create an attractive and safe public realm and sidewalk space for pedestrians and cyclists through the implementation of design, landscaping, and infrastructure. Publicly accessible spaces and sidewalks should:

- Design the transition between the public and private realm through the coordination of amenities and materials, such as accent paving, tree wells, lighting and street furniture (e.g., benches, bicycle racks, trash receptacles, and news racks).
- Complement or match accent paving to existing designs in downtown and Cal Ave areas.
- Provide sidewalk widths that accommodate landscaping, street trees, furniture, and pedestrian amenities; create a pleasant, desirable place to walk; provides shade; and enable comfortable pedestrian passage.
- Provide amenities, such as parking and repair equipment, for micromobility, such as bicycles and scooters.

(B) Streetscape

(i) Sidewalk Widths

(a) Public sidewalks abutting a development parcel shall have a minimum sidewalk width (curb to back of walk) of XXX feet [TBD in consultation with Public Works]. If the existing public sidewalk does not meet the minimum standard,² a publicly accessible extension of the sidewalk, with corresponding public access easement, shall be provided.

1. Notwithstanding subsection (a), the following streets/locations shall have a ³minimum sidewalk width of:

- a. Park Boulevard (South of Caltrain to Ventura): TBD, per NVCAP
- b. El Camino Real and San Antonio Avenue: 12 ft
- c. Other Corridors in Commercial Zones (CN, CS, CC, CC(2)) : 8ft
- d. CD Districts and SOFA: 10 ft

(b) Publicly accessible sidewalks or walkways connecting through a development parcel (e.g., on a through lot) shall have a ⁴minimum six-foot width. Pedestrian walkways that are designed to provide access to bicycles shall have a minimum width of eight feet.

(ii) Street Trees

(a) Sidewalks shall include at least one street tree, within six feet of the sidewalk, for every 30 feet of linear feet of sidewalk length. **WHERE POSSIBLE.** ⁵

COVID ERA
SUGGESTION, WITH 6'
SIDEWALKS, CONSIDER
WAITING/PASSING
ZONES IN LANDSCAPE
AREA, TO ALLOW FOR
PHYSICALLY
DISTANCED PASSING

Page: 3

Number: 1 Author: elaine Subject: Highlight Date: 12/5/2020 3:28:49 PM

To create an attractive and safe public realm and sidewalk space for pedestrians and cyclists through the implementation of design, landscaping, and infrastructure. Publicly accessible spaces and sidewalks should:

- Design the transition between the public and private realm through the coordination of amenities and materials, such as accent paving, tree wells, lighting and street furniture (e.g., benches, bicycle racks, trash receptacles, and news racks).
- Complement or match accent paving to existing designs in downtown and Cal Ave areas.
- Provide sidewalk widths that accommodate landscaping, street trees, furniture, and pedestrian amenities; create a pleasant, desirable place to walk; provides shade; and enable comfortable pedestrian passage.
- Provide amenities, such as parking and repair equipment, for micromobility, such as bicycles and scooter

Number: 2 Author: elaine Subject: Highlight Date: 12/5/2020 3:44:11 PM

, a publicly accessible extension of the sidewalk, with corresponding public access easement, shall be provided.

Number: 3 Author: elaine Subject: Text Box Date: 12/5/2020 3:44:49 PM

COVID ERA SUGGESTION, WITH 6' SIDEWALKS, CONSIDER WAITING/PASSING ZONES IN LANDSCAPE AREA, TO ALLOW FOR PHYSICALLY DISTANCED PASSING

Number: 4 Author: elaine Subject: Highlight Date: 12/5/2020 3:43:15 PM

minimum six-foot width

Number: 5 Author: elaine Subject: Text Box Date: 12/5/2020 1:31:48 PM

WHERE POSSIBLE.

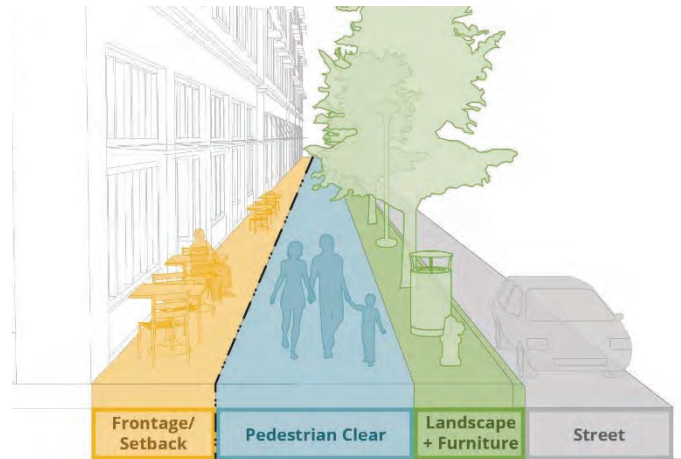
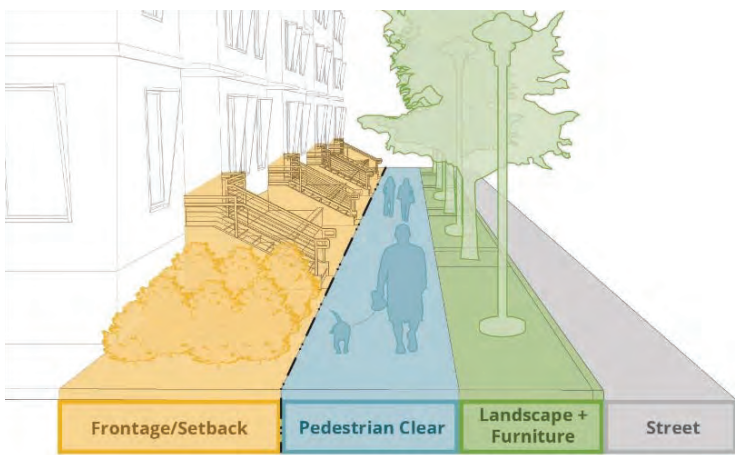

LABELS THESE DIAGRAMS (MIXED USE VS RESIDENTIAL?) AND EXPLAIN THE DIFFERENCES IN USE AND DIMENSIONAL REQUIREMENTS

Frontage		Sidewalk		Street
Building Setback	Frontage Area	Pedestrian Clear Zone	Landscape/Furniture Zone	
Property Line Varies			Landscape/Furniture Area	Edge Zone 18" typ. Curb + Step Out Area
<i>Mixed-Use</i> <ul style="list-style-type: none"> • Sidewalk Dining • Outdoor Displays • Public Art • Seating • Planting 			<ul style="list-style-type: none"> • Street Trees/Planting • Street Lighting • Seating • Mobility Infrastructure • Bike Parking • Public Art • Outdoor Dining 	<ul style="list-style-type: none"> • Street Parking • Bike Lanes • Drop-off Zones • Parklets
<i>Residential</i> <ul style="list-style-type: none"> • Stoops • Porches • Front Yards • Utilities • Planting 				

ALLOW FOR FLEXIBILITY AND BETTER DESIGN CHOICES. WHAT IF EXISTING PAVING IS NOT IDEAL? FOR EXAMPLE, THE RECYCLED GLASS ALONG CAL AVE IS KIND OF DANGEROUS FOR LITTLE KIDS, AND UNEVEN AND SUBOPTIMAL FROM AN ACCESSIBILITY STANDPOINT

(iii) Accent Paving

(a) Sidewalks and publicly accessible areas fronting University Avenue and California Avenue shall match existing accent paving design and materials, such as a mosaic tile and bricks.

(iv) Mobility Infrastructure

(a) Micromobility infrastructure, such as locations to lock bicycles and scooters, shall be located within 20 feet of the primary building entry and/or a path leading to the primary building entry. This standard may be satisfied by existing

Page: 4

☰ Number: 1 Author: elaine Subject: Text Box Date: 1/18/2021 8:52:28 AM

LABELS THESE DIAGRAMS (MIXED USE VS RESIDENTIAL?) AND EXPLAIN THE DIFFERENCES IN USE AND DIMENSIONAL REQUIREMENTS

☰ Number: 2 Author: elaine Subject: Text Box Date: 1/18/2021 8:50:30 AM

ALLOW FOR FLEXIBILITY AND BETTER DESIGN CHOICES. WHAT IF EXISTING PAVING IS NOT IDEAL? FOR EXAMPLE, THE RECYCLED GLASS ALONG CAL AVE IS KIND OF DANGEROUS FOR LITTLE KIDS, AND UNEVEN AND SUBOPTIMAL FROM AN ACCESSIBILITY STANDPOINT

📄 Number: 3 Author: elaine Subject: Highlight Date: 12/5/2020 1:34:47 PM

) Sidewalks and publicly accessible areas fronting University Avenue and California Avenue shall match existing accent paving design and materials, such a mosaic tile and bricks.

infrastructure already located within 50 feet of the project site and located in the public right-of-way.

- (b) Primary building entries shall provide at least one seating area or bench within 20 feet of building entry and/or path leading to building entry. This standard may be satisfied by existing seating area or benches located in public right-of-way within 50 feet of the building entry.

18.24.030 Site Access

1 (A) Intent

To provide facilities and accommodations for pedestrians, vehicles, cyclists, and transit users to safely and efficiently access and circulate both within individual sites and in the site's surrounding context. Site access should include the following elements:

- Site circulation and access that presents a clear hierarchy and connectivity pattern for all travel modes both within a project and to adjacent sidewalks and transit stops. This hierarchy may provide separate access for vehicles and other modes, or demonstrate how all modes are accommodated in shared access points.
- Connections to side streets, open spaces, mews, alleys, and paseos
- Vehicle, loading and service access that is integrated into building and landscape design and located to prevent conflicts with pedestrians and cyclists, while also provided convenient access to building entries.

(B) Circulation Hierarchy

- (i) Sites shall clearly identify a hierarchy of connectivity in a circulation plan that identifies a priority for pedestrian, bike, private vehicles, and utility/loading access in the order listed. [see comment in text box below]
- (ii) Through lots located more than 300 feet from an intersecting street or pedestrian walkway shall provide a publicly accessible sidewalk or pedestrian walkway connecting the two streets. **UNDER CIRCULATION HIERARCHY, PLEASE INCLUDE AND REFERENCE ACCESS/INFRASTRUCTURE FOR MICROMOBILITY** ²

(C) Building Entries **VEHICLES. ALLOW FLEXIBILITY FOR FUTURE TRANSPORT MODES**

- (i) Entries to Primary Building Entries shall be located from a public right-of-way or if not possible a publicly accessible Pedestrian Walkway.

Circulation Plan: Some topics are inherently difficult to create clear and objective standards to meet the intent of the guidelines while providing flexibility that is needed for each project. One way to create an objective standard for these performance criteria is to have a requirement that a developer submit a plan to meet these criteria. The review of the plan material, description of how the project will meet the intent of the guidelines, and the implementation will not be objective and thus not applicable to deny a project for not meeting the City's expectations of the guidelines, but the act of having to write the report/plan may provide enough guidance and design thinking to get most of the way there in most cases.

Number: 1 Author: elaine Subject: Highlight Date: 12/5/2020 3:28:12 PM

(A) Intent

To provide facilities and accommodations for pedestrians, vehicles, cyclists, and transit users to safely and efficiently access and circulate both within individual sites and in the site's surrounding context. Site access should include the following elements:

Site circulation and access that presents a clear hierarchy and connectivity pattern for all travel modes both within a project and to adjacent sidewalks and transit stops.

This hierarchy may provide separate access for vehicles and other modes, or demonstrate how all modes are accommodated in shared access points.

Connections to side streets, open spaces, mews, alleys, and paseos

Vehicle, loading and service access that is integrated into building and landscape design and located to prevent conflicts with pedestrians and cyclists, while also provided convenient access to building entries.

Number: 2 Author: elaine Subject: Text Box Date: 12/5/2020 1:42:29 PM

UNDER CIRCULATION HIERARCHY, PLEASE INCLUDE AND REFERENCE ACCESS/INFRASTRUCTURE FOR MICROMOBILITY VEHICLES. ALLOW FLEXIBILITY FOR FUTURE TRANSPORT MODES

1

DOES VEHICLE ACCESS MEAN CARS/TRUCKS/MOTORCYCLES?
MICROMOBILITY VEHICLES SHOULD HAVE A SEPARATE CATEGORY.
THEIR USE CASES AND TRAVEL ZONES ARE DIFFERENT

(D) Vehicle Access

- (i) Vehicle access shall be located on alleys or side streets where available.
- (ii) Vehicle access, vehicle loading, and off-street parking shall follow the following standards:
 - (a) Except for driveway access, off-street parking, off-street vehicle loading, and vehicular circulation areas are prohibited between the building and the primary building frontage.
- (iii) Special Conditions
 - (b) California Avenue: Vehicular access to CC(2) zoned sites on California Avenue which requires vehicular movement across the sidewalk on California Avenue shall be prohibited, except where required by law and as applied to parcels owned, leased or controlled by the City.
 - (c) University Avenue: Vehicular access to CD-C zoned sites on University Avenue which requires vehicular movement across the sidewalk on University Avenue shall be prohibited, except where required by law and as applied to parcels owned, leased or controlled by the City.

(E) Loading Docks and Service Areas

- (iii) Loading and service areas shall be integrated into building and landscape design and located to minimize impact on the pedestrian experience as follows:
 - (a) Loading docks and service areas shall be located on facades other than the primary building frontage, on alleys, from parking areas, and/or at the rear or side of building if building includes these frontages. When only primary building frontage is available, ²loading docks and service areas shall be recessed a minimum five feet from the primary façade and shall be screened in accordance with Chapter 18.23.050.
 - (b) Loading dock and service areas located ³within setback areas shall be screened in accordance with Chapter 18.23.050 and separated from pedestrian access to the primary building entry to avoid impeding pedestrian movement and safety.

ON SITES WITH ONLY ONE FRONTAGE, YOU'LL NEED FLEXIBILITY DUE TO COMPETING DEMANDS OF OTHER INFRASTRUCTURE ALONG THE STREET FRONTAGE.. RECOMMEND ALLOWING SERVICE AREAS TO BE WITHIN THE SETBACK, NOT A FORCED RECESS FROM THE PRIMARY FAÇADE. SCREENING WILL BE IMPORTANT, BUT THERE SHOULD BE FLEXIBILITY ON THE SCREENING TYPE

4

18.24.040 Building Orientation and Setbacks

⁵(A) Intent

To create a coherent and active interface between private development and the public realm that contributes to the sense of place and structure of the neighborhood and enhances the public's experience. Site design that responds to the orientation of adjacent uses and creates opportunities for landscaping and usable open space. Buildings and site design should meet the following criteria:

- Buildings that create a contiguous street wall that are compatible with nearby buildings and land uses.
- Placement and orientation of doorways, windows, stoops, and landscape elements to create a direct relationship with the street

Page: 6

☰ Number: 1 Author: elaine Subject: Text Box Date: 12/5/2020 1:44:08 PM

DOES VEHICLE ACCESS MEAN CARS/TRUCKS/MOTORCYCLES? MICROMOBILITY VEHICLES SHOULD HAVE A SEPARATE CATEGORY. THEIR USE CASES AND TRAVEL ZONES ARE DIFFERENT

📌 Number: 2 Author: elaine Subject: Highlight Date: 12/5/2020 1:44:14 PM

, loading docks and service areas shall be recessed a minimum five feet

📌 Number: 3 Author: elaine Subject: Highlight Date: 12/5/2020 1:44:39 PM

within setback areas shall be screened in accordance with Chapter 18.23.050

☰ Number: 4 Author: elaine Subject: Text Box Date: 12/5/2020 1:51:30 PM

ON SITES WITH ONLY ONE FRONTAGE, YOU'LL NEED FLEXIBILITY DUE TO COMPETING DEMANDS OF OTHER INFRASTRUCTURE ALONG THE STREET FRONTAGE.. RECOMMEND ALLOWING SERVICE AREAS TO BE WITHIN THE SETBACK, NOT A FORCED RECESS FROM THE PRIMARY FACADE. SCREENING WILL BE IMPORTANT, BUT THERE SHOULD BE FLEXIBILITY ON THE SCREENING TYPE.

📌 Number: 5 Author: elaine Subject: Highlight Date: 12/5/2020 3:30:11 PM

(A) Intent

To create a coherent and active interface between private development and the public realm that contributes to the sense of place and structure of the neighborhood and enhances the public's experience. Site design that responds to the orientation of adjacent uses and creates opportunities for landscaping and usable open space. Buildings and site design should meet the following criteria:

Buildings that create a contiguous street wall that are compatible with nearby buildings and land uses.

Placement and orientation of doorways, windows, stoops, and landscape elements to create a direct relationship with the street

- Ground floor residential units that have direct entry and presence on the street
- Transitional spaces and buffer areas between buildings, parcels, and sites through building setbacks that distinguish private and public spaces.
- Buildings that provide side and rear setbacks and/or upper story stepbacks to create separation between adjacent lower density residential development.
- Landscaped or usable areas that contain open space or hardscaped areas.
- Optimized building orientation for heat gain, shading, daylighting, and natural ventilation and other forms of passive design.

(B) Building Orientation

IS THERE A SECTION FOR MID-BLOCK BUILDINGS, WITH NEIGHBORS ON ON 2 SIDES? 1

(i) Treatment of Corner Buildings

(a) Corner buildings shall include one of the following special features:

1. Street wall shall be located at the minimum front yard setback or build-to line 3 or a minimum aggregated length of 50 feet in length on both facades meeting at the corner and shall include one or more of the following building features:
 - a. A corner entry to ground floor retail or primary building entrance
 - b. A different material application and fenestration pattern from the rest of the façade
 - c. A change in height of at least 8 feet greater or less than the height of the abutting façade.

WHY 60'? THE HISTORIC BUILDING AT RAMONA AND UNIVERSITY AVE - ONE OF PALO ALTO'S MOST ICONIC BUILDINGS - PROBABLY WOULD NOT MEET THIS STANDARD

CORNER TREATMENTS MAY HAVE DIFFERENT CONSIDERATIONS ALONG ECR OR SAN ANTONIO VS UNIVERSITY AVE. EVEN A CORNER BLDG ON A SMALLER STREET LIKE LYTTON AVE OR COLLEGE AVE MAY NEED DIFFERENT STANDARDS 4

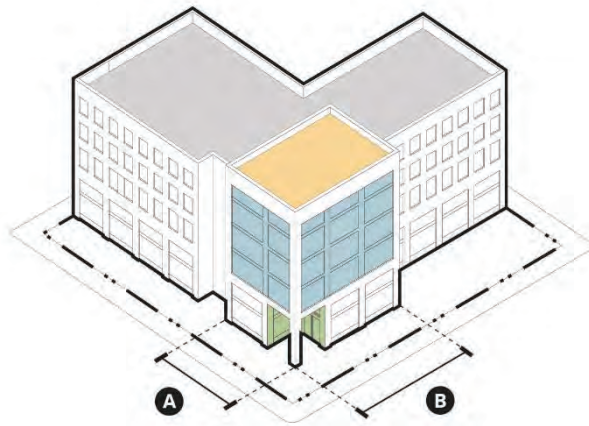

- A Length 1 of corner building
- B Length 2 of corner building
- where: A + B > 60'
- Corner Entry or Primary Building Entrance
- Variation in fenestration pattern
- Change in height of ≥ 8' from abutting façade

Page: 7

-
- ☰ Number: 1 Author: elaine Subject: Text Box Date: 12/5/2020 2:11:08 PM
IS THERE A SECTION FOR MID-BLOCK BUILDINGS, WITH NEIGHBORS ON ON 2 SIDES?
-
- 📄 Number: 2 Author: elaine Subject: Highlight Date: 12/5/2020 1:52:08 PM
60 feet
-
- ☰ Number: 3 Author: elaine Subject: Text Box Date: 1/18/2021 8:53:29 AM
WHY 60'? THE HISTORIC BUILDING AT RAMONA AND UNIVERSITY AVE - ONE OF PALO ALTO'S MOST ICONIC BUILDINGS - PROBABLY WOULD NOT MEET THIS STANDARD
-
- ☰ Number: 4 Author: elaine Subject: Text Box Date: 12/5/2020 2:23:55 PM
CORNER TREATMENTS MAY HAVE DIFFERENT CONSIDERATIONS ALONG ECR OR SAN ANTONIO VS UNIVERSITY AVE. EVEN A CORNER BLDG ON A SMALLER STREET LIKE LYTTON AVE OR COLLEGE AVE MAY NEED DIFFERENT STANDARDS

2. A publicly accessible open space with a minimum dimension of ¹20 feet and minimum area of 1,000 square feet.

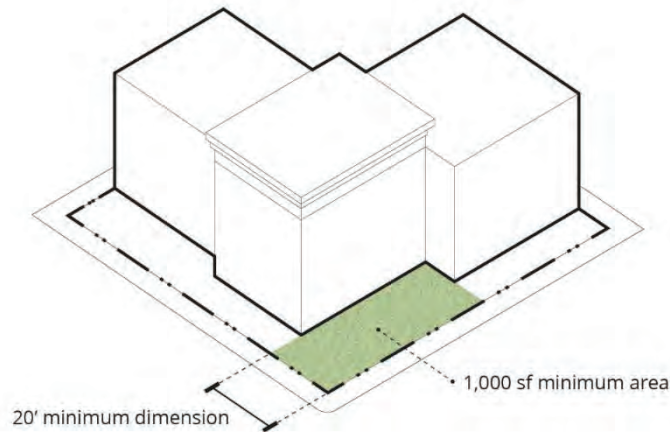

² NARROW DEPTH SITES MAY NEED AN EXEMPTION. A LOT OF GOOD PUBLIC ACTIVITY CAN HAPPEN IN A 12-15' DEPTH. 1000SF OVERALL SEEMS HIGH (20'X50'!), ESPECIALLY ON SMALLER SITES. RECOMMEND 500 SF MIN OR A GRADUATED MINIMUM BASED ON MINIMUM LOT SIZE (IE 500 SF FOR SITES < 1/4 ACRE, 750 FOR SITES < 1/2 ACRE AND 1000 SF FOR SITES OVER 1/2 ACRE.

3. A common open space that is no more than six feet above the back of walk grade at the corner, is located adjacent to indoor common spaces, with direct access, has areas for seating, has a minimum dimension of ³20 feet and ⁴minimum area of ⁴1,000 square feet, and has a fence or railing that is no less than 50 percent open or transparent.

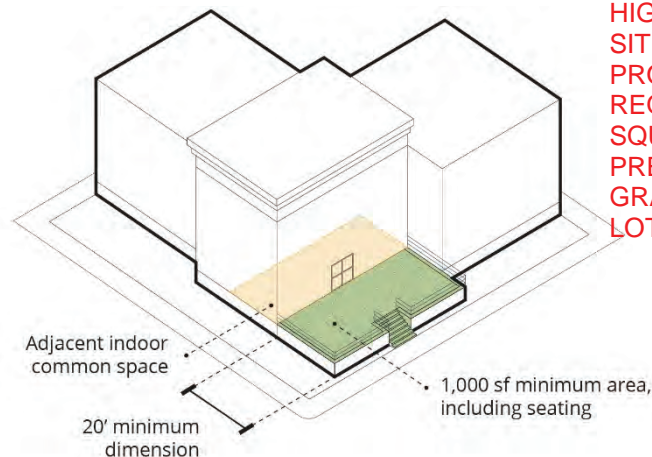







⁵ AGAIN THESE DIMENSIONS FOR AN INTERIOR COMMON SPACE SEEM HIGH, ESPECIALLY FOR SMALLER SITES, OR BLDGS WITH COMPLEX PROGRAMS AND INFRASTRUCTURE REQUIREMENTS WHERE EVERY SQUARE FOOT ON GROUND FLOOR IS PRECIOUS. THINK ABOUT GRADUATED STANDARDS BASED ON LOT SIZE

(ii) Primary Building Entry

- (a) The primary building entry shall meet one of the following standards:
1. Face a public right-of-way. Be visible from a public right-of-way through a forecourt or front porch that meets the following standards:
 - a. For residential buildings with fewer than seven units, building entry forecourts or front porches shall be a minimum area of 36 square feet and ⁷minimum dimension of five feet.
 - b. For commercial buildings or residential buildings with more than six units, building entry forecourts or front porches shall be a minimum of 100 square feet and a minimum width of 8 feet.

Page: 8

-
-  Number: 1 Author: elaine Subject: Highlight Date: 12/5/2020 1:59:49 PM
20 feet
-
-  Number: 2 Author: elaine Subject: Text Box Date: 12/5/2020 2:24:10 PM
NARROW DEPTH SITES MAY NEED AN EXEMPTION. A LOT OF GOOD PUBLIC ACTIVITY CAN HAPPEN IN A 12-15' DEPTH. 1000SF OVERALL SEEMS HIGH (20'X50'!), ESPECIALLY ON SMALLER SITES. RECOMMEND 500 SF MIN OR A GRADUATED MINIMUM BASED ON MINIMUM LOT SIZE (IE 500 SF FOR SITES < 1/4 ACRE, 750 FOR SITES <1/2 ACRE AND 1000 SF FOR SITES OVER 1/2 ACRE.
-
-  Number: 3 Author: elaine Subject: Highlight Date: 12/5/2020 2:04:38 PM
20 feet and
minimum area of
-
-  Number: 4 Author: elaine Subject: Highlight Date: 12/5/2020 2:04:29 PM
1,000 square feet,
-
-  Number: 5 Author: elaine Subject: Text Box Date: 1/18/2021 8:55:11 AM
AGAIN THESE DIMENSIONS FOR AN INTERIOR COMMON SPACE SEEM HIGH, ESPECIALLY FOR SMALLER SITES, OR BLDGS WITH COMPLEX PROGRAMS AND INFRASTRUCTURE REQUIREMENTS WHERE EVERY SQUARE FOOT ON GROUND FLOOR IS PRECIOUS. THINK ABOUT GRADUATED STANDARDS BASED ON LOT SIZE
-
-  Number: 6 Author: elaine Subject: Text Box Date: 12/5/2020 2:07:07 PM
.
-
-  Number: 7 Author: elaine Subject: Highlight Date: 12/5/2020 2:52:52 PM
minimum dimension of five feet.

(iii) Ground Floor Residential Units

- (a) A minimum of 80% of ground floor residential units facing a public right-of-way or publicly accessible path or open space shall have a unit entry with direct access to the sidewalk, path, or open space. (Senior units or other deed-restricted units for special populations are exempt)
- (b) Entries to ground floor residential units shall face a public right-of-way or publicly accessible path/open space or be visible from a public right-of-way through a forecourt or front porch that is a minimum of 30 square feet.
- (c) ¹Ground floor residential units shall be setback a minimum 15 feet from the back of sidewalk.

CONSIDER VARIANCES FOR NARROW DEPTH SITES. MOST PRE-WW2 STRUCTURES DON'T HAVE 15' SETBACKS AND WORK , ESP FOR SMALL MULTIFAMILY LIKE RM-20 THRU RM-50 "MISSING MIDDLE" TYPE HOUSING

2

(C) Front Yard Setback Character

- (i) Required setbacks shall provide an extension of the sidewalk as a hardscape and/or landscaped area to create a transition between public and private space. The following standards apply, based on intended use and exclusive of areas devoted to outdoor seating, front porches, door swing of building entries, and publicly accessible open space:
 - (a) Ground-floor retail or retail-like uses = Minimum of 20% of the required setback
 - (b) ³Other ground-floor non-residential uses. A minimum of 40% of the required setback area Ground-floor residential uses. A minimum of 60% of the required setback area

NOT CLEAR.

4

18.24.050 Building Massing

⁵(A) Intent

To create buildings that are compatible with and enhance the surrounding area through the consideration of building scale, massing, and bulk. Massing should create a human-scale environment that is of high aesthetic quality and accommodates a variety of uses and design features. Building massing should include elements that:

- Break down large building facades and massing to create a human-scaled building that enhances the context of the site
- Are consistent in scale, mass and character to adjacent land uses and land use designations
- Reinforce the definition and importance of the street
- Provide rooflines and massing that emphasize and accentuate significant elements of the building such as entries, bays, and balconies, and shading elements where ⁶appropriate.
- Provide harmonious transitions between adjacent properties

(B) Contextual Massing

MOST PEOPLE NEVER EXPERIENCE BUILDINGS AT THIS HEIGHT AND NEVER NOTICE SETBACKS.

7

(i) Upper Floor Step Backs

- (c) When the average height of the building is greater than 20 feet above the average height of an adjacent building, an upper floor step back shall start within 2 vertical feet, plus or minus, of the height of the adjacent building, be a minimum depth of six feet along the primary building frontage, and the step should shall occur for a minimum of 70% of the façade length.

Page: 9

Number: 1 Author: elaine Subject: Highlight Date: 12/5/2020 2:08:10 PM
 Ground floor residential units shall be setback a minimum 15 feet from the back of sidewalk.

Number: 2 Author: elaine Subject: Text Box Date: 1/18/2021 8:56:06 AM

CONSIDER VARIANCES FOR NARROW DEPTH SITES. MOST PRE-WW2 STRUCTURES DON'T HAVE 15' SETBACKS AND WORK , ESP FOR SMALL MULTIFAMILY LIKE RM-20 THRU RM-50 "MISSING MIDDLE" TYPE HOUSING

Number: 3 Author: elaine Subject: Highlight Date: 12/5/2020 2:09:50 PM
) Other ground-floor non-residential uses. A minimum of 40% of the required setback area Ground-floor residential uses. A minimum of 60% of the required setback area

Number: 4 Author: elaine Subject: Text Box Date: 12/5/2020 2:09:59 PM

NOT CLEAR.

Number: 5 Author: elaine Subject: Highlight Date: 12/5/2020 3:29:35 PM

(A) Intent

To create buildings that are compatible with and enhance the surrounding area through the consideration of building scale, massing, and bulk. Massing should create a human-scale environment that is of high aesthetic quality and accommodates a variety of uses and design features. Building massing should include elements that:

- Break down large building facades and massing to create a human-scaled building that enhances the context of the site

- Are consistent in scale, mass and character to adjacent land uses and land use designations

- Reinforce the definition and importance of the street

- Provide rooflines and massing that emphasize and accentuate significant elements of the building such as entries, bays, and balconies, and shading elements

Number: 6 Author: elaine Subject: Highlight Date: 12/5/2020 3:29:39 PM

appropriate.

- Provide harmonious transitions between adjacent properti

Number: 7 Author: elaine Subject: Text Box Date: 12/5/2020 3:50:02 PM

MOST PEOPLE NEVER EXPERIENCE BUILDINGS AT THIS HEIGHT AND NEVER NOTICE SETBACKS.

IN PALO ALTO, LEFT SIDE DIAGRAM CURRENTLY NOT ALLOWED BUT IT SHOULD BE! SIX STORY STRUCTURES ARE NOT FEASIBLE - SINCE THEY ARE OVER 50'! :)

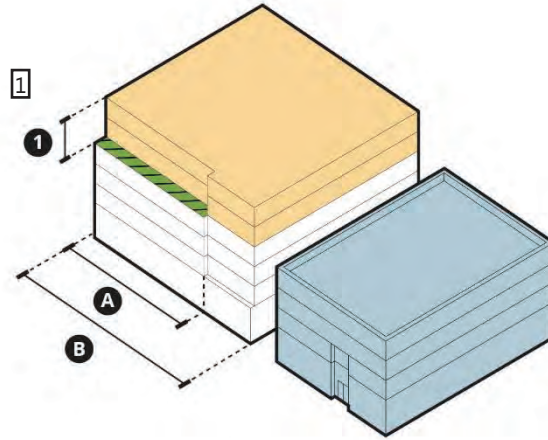

RIGHT SIDE DIAGRAM OF THIS BLDG IS THE TALLEST ALLOWABLE IN PALO ALTO RIGHT NOW! YOU MAY WANT TO EDIT TO SHOW RELATIONSHIP BETWEEN 2 STORY AND 4 STORY STRUCTURE

- 1 Building height $\geq 20'$ above adjacent building
- A Step back along $\geq 70\%$ length of B
- Step back area $\leq 6'$ depth along primary facade
- B Building frontage

(ii) Transition to Lower Density Building Types

(d) When a building abuts a side and/or rear property line with a RE, RMD, R-1, or R-2 zoned parcel or a village residential or existing single-family residential use, the building shall break down the abutting façade by meeting the following standards:

1. A reduction in mass through one of the following:
 - a. A minimum 15-foot building setback and an upper floor step back above 35 feet in height for a minimum depth of 25 feet.
 - b. Jodie - to add IR privacy type Guidelines that are objective
 - (i) Frosted windows
 - (ii) Staggered window placement

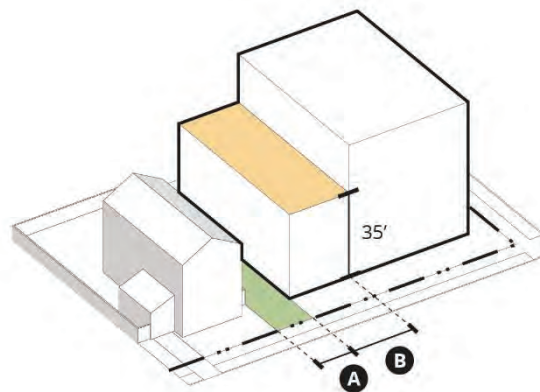

- A Minimum side or rear setback $\geq 15'$
- B Upper floor step back $\geq 25'$ deep

☰ Number: 1 Author: elaine Subject: Text Box Date: 1/18/2021 8:57:12 AM

IN PALO ALTO, LEFT SIDE DIAGRAM CURRENTLY NOT ALLOWED BUT IT SHOULD BE! SIX STORY STRUCTURES ARE NOT FEASIBLE - SINCE THEY ARE OVER 50'! :)

☰ Number: 2 Author: elaine Subject: Text Box Date: 1/18/2021 8:56:40 AM

RIGHT SIDE DIAGRAM OF THIS BLDG IS THE TALLEST ALLOWABLE IN PALO ALTO RIGHT NOW! YOU MAY WANT TO EDIT TO SHOW RELATIONSHIP BETWEEN 2 STORY AND 4 STORY STRUCTURE

- c. A minimum ¹20-foot building side yard setback, a minimum 10-foot step back above 30 feet in height, and a landscape screen that includes a double row of trees with a minimum 1 tree per 30 linear feet plus continuous shrubbery planting 72 inches (6 feet) in height [NOTE: Alternative is to maintain existing daylight plane]

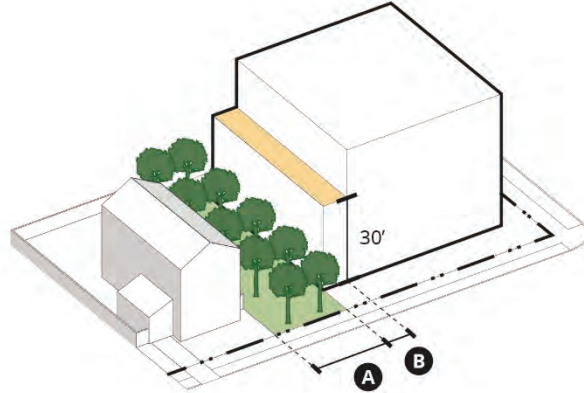

- A Minimum side or rear setback $\geq 30'$ including double row of trees
- B Upper floor step back $\geq 10'$ deep

THIS WILL BE TOUGH TO ACHIEVE ON SMALLER OR NARROW DEPTH SITES (<60'). IN ADDITION TO MAINTAINING EXISTING DAYLIGHT PLANE AS AN ALTERNATE OR OPTION, PLEASE CONSIDER APPROACH - DIFFERENT CRITERIA FOR SITES

- A) <60' MIGHT HAVE A 8' LANDSCAPE BUFFER
- B) 60-100' MIGHT HAVE A 10'-12' BUFFER
- C) >100' COULD ACCOMODATE 15'-20'

- 2. A minimum façade break of ³six feet in width and six feet in depth for every 36 to 40 feet of façade length. ⁴

6' DEPTH IS A LOT ESPECIALLY ON SMALLER SITES, <100' IN ONE DIRECTION. 2-3' IS BETTER AND STRUCTURALLY EASIER/CHEAPER TO CONSTRUCT.,

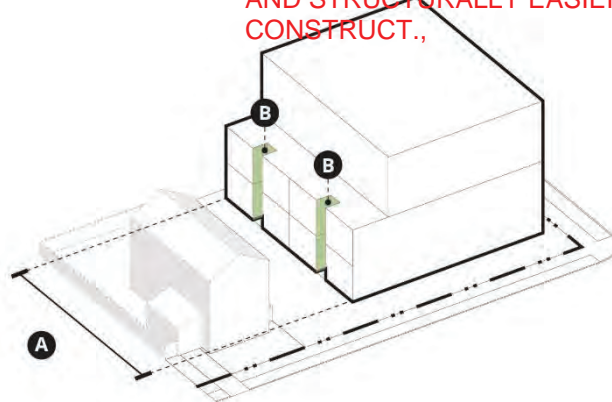

- A Building facade $\geq 40'$
- B 6' wide, 6' deep break

- 3. A maximum 15% window coverage of facades within 30 feet of abutting property line.

Page: 11

 Number: 1 Author: elaine Subject: Highlight Date: 12/5/2020 2:17:10 PM
20-foot building side yard setback, a minimum 10-foot step back
above 30 feet in height

 Number: 2 Author: elaine Subject: Text Box Date: 12/5/2020 2:26:08 PM

THIS WILL BE TOUGH TO ACHIEVE ON SMALLER OR NARROW DEPTH SITES (<60'). IN ADDITION TO MAINTAINING EXISTING DAYLIGHT PLANE AS AN ALTERNATE OR OPTION, PLEASE CONSIDER APPROACH - DIFFERENT CRITERIA FOR SITESA) <60' MIGHT HAVE A 8' LANDSCAPE BUFFERB) 60-100' MIGHT HAVE A 10'-12 BUFFERC) >100' COULD ACCOMODATE 15'-20'

 Number: 3 Author: elaine Subject: Highlight Date: 12/5/2020 2:35:22 PM
f six feet in width and six feet in dept

 Number: 4 Author: elaine Subject: Text Box Date: 1/18/2021 8:59:24 AM

6' DEPTH IS A LOT ESPECIALLY ON SMALLER SITES, <100' IN ONE DIRECTION. 2-3' IS BETTER AND STRUCTURALLY EASIER/ CHEAPER TO CONSTRUCT.,

(C) Maximum Façade Length

(i) Significant Breaks

(a) For portions of a building facade facing a public street, right-of-way, or publicly accessible path, any building greater than 25 feet in height shall not have a continuous facade greater than 70% of the façade length. Upper floor façade modulation shall be a **1** minimum 2 feet in depth.

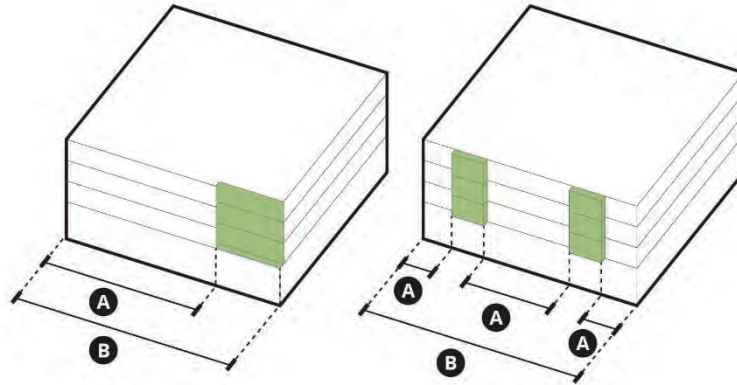

- A** Non-continuous building facade \leq 70% length of **B**
- B** Building length
- Upper floor above 25' with modulation \geq 2' in depth

100' LONG SITES ARE NOT THAT LONG/WIDE, INSTEAD OF MANDATING THIS HUGE BREAK, USE MASSING TO CONTROL VARIATION ALONG A FACADE, ALTERNATIVE: CHANGE 100' TO BLDGS OVER 200' IN LENGTH

2

(b) Buildings greater than **3** 100 feet in length, which face a public street, right-of-way, **4** or publicly accessible path, shall have at least one vertical façade break with a minimum area greater than **5** 600 square feet and a width less than or equal to two times the depth.





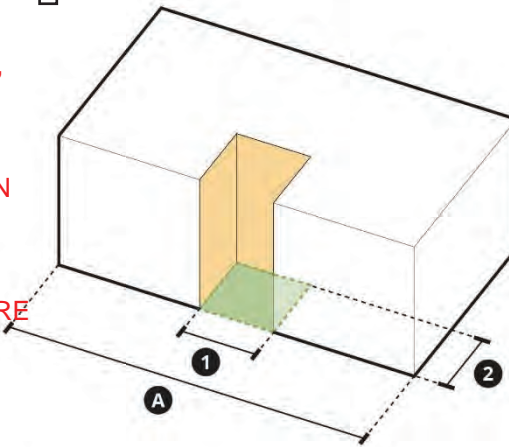

A MINIMUM 600 SF VERTICAL BREAK IS A LOT, THIS SHOULD NOT BE MORE THAN 0-100 SF. ON A TYPICAL DOWNTOWN SITE, 150' WIDE X 150' SITE THIS STANDARD WOULD REQUIRE A 20' X 30' BREAK SOMEWHERE? IT'S FINE TO HAVE AN OBJECTIVE STANDARD THAT REQUIRES AN OPEN SPACE, BUT ALLOW THE APPLICANT FLEXIBILITY ON HOW TO REDUCE OR MODULATE BUILDING MASS AND OPEN SPACE. THIS STANDARDS DESCRIBED HERE ARE TOO ONEROUS AND CAN CONSTRAIN GOOD DESIGN ALTERNATIVES OR MAKE DEVELOPMENT INFEASIBLE.

6



- A** Building facade \geq 100'
- Vertical facade break
- Facade break area \geq 600 sf
- 1** Facade break width \leq (2 * **2**)
- 2** Facade break depth

Page: 12

-
-  Number: 1 Author: elaine Subject: Highlight Date: 12/5/2020 2:36:24 PM
minimum 2 feet in dept
-
-  Number: 2 Author: elaine Subject: Text Box Date: 12/5/2020 2:34:25 PM
100' LONG SITES ARE NOT THAT LONG/WIDE, INSTEAD OF MANDATING THIS HUGE BREAK, USE MASSING TO CONTROL VARIATION ALONG A FACADE, ALTERNATIVE: CHANGE 100' TO BLDGS OVER 200' IN LENGTH
-
-  Number: 3 Author: elaine Subject: Highlight Date: 12/5/2020 2:29:45 PM
100 feet
-
-  Number: 4 Author: elaine Subject: Text Box Date: 12/5/2020 2:34:17 PM
-
-  Number: 5 Author: elaine Subject: Highlight Date: 12/5/2020 2:27:21 PM
600 square feet
-
-  Number: 6 Author: elaine Subject: Text Box Date: 1/18/2021 9:00:38 AM
A MINIMUM 600 SF VERTICAL BREAK IS A LOT, THIS SHOULD NOT BE MORE THAN 0-100 SF. ON A TYPICAL DOWNTOWN SITE, 150' WIDE X 150' SITE THIS STANDARD WOULD REQUIRE A 20' X 30' BREAK SOMEWHERE? IT'S FINE TO HAVE AN OBJECTIVE STANDARD THAT REQUIRES AN OPEN SPACE, BUT ALLOW THE APPLICANT FLEXIBILITY ON HOW TO REDUCE OR MODULATE BUILDING MASS AND OPEN SPACE. THIS STANDARDS DESCRIBED HERE ARE TOO ONEROUS AND CAN CONSTRAIN GOOD DESIGN ALTERNATIVES OR MAKE DEVELOPMENT INFEASIBLE.

(D) Special Conditions**(i) Railroad Frontages**

- (a) All parcels with lot lines abutting railroad rights-of-way shall meet the following standards on the railroad-abutting facade:
1. A minimum facade break of at least 10 feet in width and six feet in depth for every 60 feet of façade length.
 2. For portion of a building greater than 20 feet or greater in height, a maximum continuous façade length shall not exceed 60 feet.
 3. A daylight setback plane starting 10 feet in height from grade at the property line and extending at a 1:1 ratio.

18.24.060 Façade Design**1 (A) Intent Statement:**

To create cohesive and well-crafted building facades with human-scaled details that incorporate textures, colors, and other details that are compatible with and enhance the surrounding area. Facades should include the following elements:

- Human-scaled detail, articulation, and craftsmanship
- Quality of construction, craftsmanship, and design to create long lasting buildings
- Articulation of the building base or ground floor, body or middle, and top, cornice or parapet edge
- Expression of a human-scaled façade rhythm and pattern that reflects the building's use
- Fenestration that enhances the architectural character of the building
- Defined building entry that is proportional to the building and number of people served

(B) Application

- (i) All facades shall meet all the required design standards and guidelines to ensure the same level of care and integrity throughout the building design.
- (ii) Façade sidewalls located along a zero-lot line where, at time of approval are not visible from a right-of-way, are exempt.
- (iii) Façade sidewalls located along a zero-lot line, where at time of approval are visible from a right-of-way, shall continue color, material, and pattern of the main façade.

(C) Human Scaled Architecture**(i) Base/Middle/Top**

- (a) Buildings three stories or taller shall be designed to differentiate a defined base or ground floor, a middle or body, and a top, cornice, or parapet cap. Buildings two stories or less shall include a defined base and top. Each of these elements shall be distinguished from one another through use of two or more of the following four techniques:

Number: 1 Author: elaine Subject: Highlight Date: 12/5/2020 2:36:52 PM

(A) Intent Statement:

To create cohesive and well-crafted building facades with human-scaled details that incorporate textures, colors, and other details that are compatible with and enhance the surrounding area. Facades should include the following elements:

- 1. *Variation in building modulation* (select a minimum of one)
 - a. Horizontal shifts. Changes in floor plates that protrude and/or recess with a minimum dimension of two feet from the primary facade.

LOVE THESE DIAGRAMS, BUT THEY ILLUSTRATE BUILDINGS TALLER THAN PALO ALTO'S CURRENT 50' HEIGHT LIMIT (WE SHOULD ALLOW STRUCTURES THIS TALL THOUGH!)

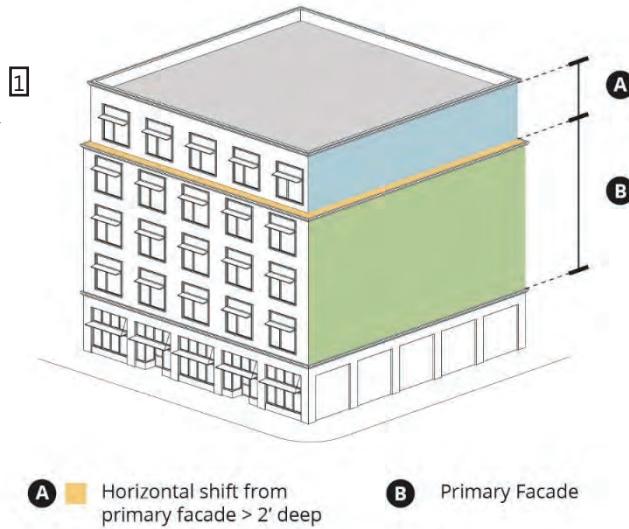

- b. Upper floor step backs. A horizontal step back of upper-floor façades with a minimum five-foot step back from the primary façade for a minimum of 80% of the length of the façade.

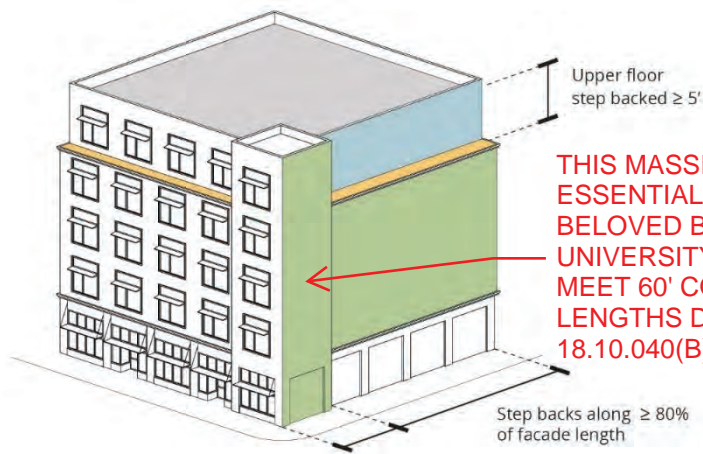

THIS MASSING IS GOOD, ESSENTIALLY A DIAGRAM OF THE BELOVED BUILDING AT RAMONA & UNIVERSITY, BUT IT MIGHT NOT MEET 60' COMBINED CORNER LENGTHS DESCRIBED IN 18.10.040(B)i(a)1

- c. Ground floor step back. A horizontal shift of the ground floor facade with a minimum depth of two feet for a minimum 80% of the length of the façade. Ground floor step backs shall not exceed the maximum setback requirements, where stated.

Page: 14

Number: 1 Author: elaine Subject: Text Box Date: 1/18/2021 9:01:08 AM

LOVE THESE DIAGRAMS, BUT THEY ILLUSTRATE BUILDINGS TALLER THAN PALO ALTO'S CURRENT 50' HEIGHT LIMIT (WE SHOULD ALLOW STRUCTURES THIS TALL THOUGH!)

Number: 2 Author: elaine Subject: Callout Date: 1/18/2021 9:01:41 AM

THIS MASSING IS GOOD, ESSENTIALLY A DIAGRAM OF THE BELOVED BUILDING AT RAMONA & UNIVERSITY, BUT IT MIGHT NOT MEET 60' COMBINED CORNER LENGTHS DESCRIBED IN 18.10.040(B)i(a)1

THIS IS A BETTER STANDARD THAN 18.24.050(C). AS LONG AS THIS IS INCLUDED, THE OTHER SHOULD NOT EXIST. AS CURRENTLY WRITTEN, THEY CONTRADICT EACH OTHER.

1

2.b

2. **For continuous facades greater than 100 feet in length**, the façade shall include a vertical recess or projection with a minimum four feet wide and two feet deep vertical shift modulation to establish a rhythm between 20 to 50 feet in width for housing units or 12 to 16 feet in width for individual rooms and spaces.

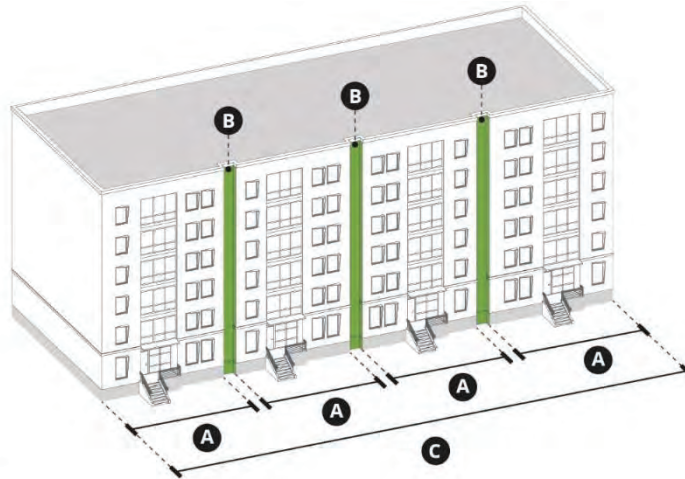

- A** 20' - 50' horizontal increment
- B** 4' wide, 2' deep vertical recesses
- C** Facade length \geq 100'
- Vertically oriented patterns

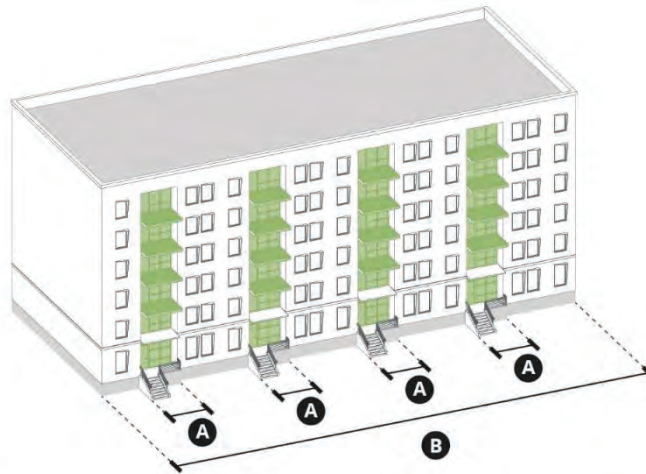



- A** 12' - 16' wide vertical recess/projections
- B** Building length \geq 100'
- Vertically oriented patterns

Page: 18

 Number: 1 Author: elaine Subject: Text Box Date: 12/5/2020 2:42:04 PM

THIS IS A BETTER STANDARD THAN 18.24.050(C). AS LONG AS THIS IS INCLUDED, THE OTHER SHOULD NOT EXIST. AS CURRENTLY WRITTEN, THEY CONTRADICT EACH OTHER.

 Number: 2 Author: elaine Subject: Cloud Date: 12/5/2020 2:39:56 PM

 Number: 3 Author: elaine Subject: Highlight Date: 12/5/2020 3:42:03 PM

For continuous facades greater than 100 feet in length

- (b) Residential mixed-use and non-residential buildings shall express a vertical rhythm and pattern by using one of the following options:
 1. Facades shall use vertical patterns of building modulation, façade articulation, and fenestration;



Vertical patterns along building facade

- 2. 1 Facades that use horizontal articulation and fenestration patterns shall use a vertical massing strategy with a minimum four feet wide and two feet deep vertical shift in modulation at least once every 50 feet of façade length.

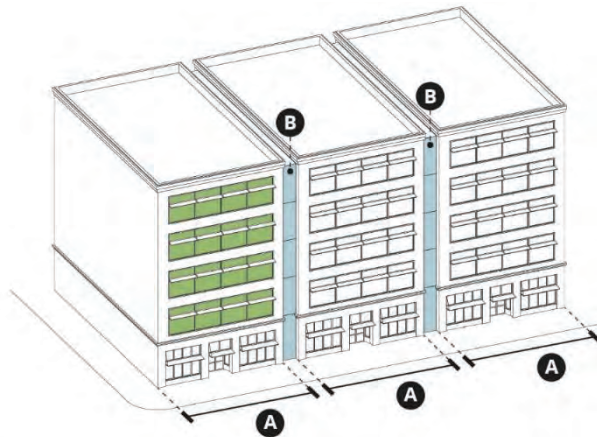

THIS STANDARD IS ALSO BETTER THAN 18.24.050(C)

2

- A** Vertical modulation \geq 50' of building length
- B** 4' wide, 2' deep vertical recesses
- Horizontally oriented patterns along building facade

- (c) Storefront uses shall express a vertical rhythm not to exceed 30 to 50 feet in width.

Page: 19

 Number: 1 Author: elaine Subject: Highlight Date: 12/5/2020 2:42:24 PM

Facades that use horizontal articulation and fenestration patterns shall use a vertical massing strategy with a minimum four feet wide and two feet deep vertical shift in modulation at least once every 50 feet of façade length.

 Number: 2 Author: elaine Subject: Text Box Date: 12/5/2020 2:42:42 PM

THIS STANDARD IS ALSO BETTER THAN 18.24.050(C)

(D) Ground Floor Character**(i) Storefront/Retail Ground Floors**

- (a) Ground floor height shall be a **minimum 14 feet floor-to-floor** or shall maintain a 2nd floor datum line of an abutting building-
- (b) Transparency shall include a minimum 60 percent transparent glazing between 2 and 10 feet in height from sidewalk, providing unobstructed views into the commercial space.
- (c) Bulkheads and solid base walls: If provided, shall measure between 12 and 30 inches from finished grade
- (d) Primary entries shall include weather protection that is a **minimum 2.5 feet wide and 4 feet deep** by recessing the entry, providing an awning or using a combination of these methods.
- (e) Awnings, canopies and weather protection:
- When transom windows are above display windows, awnings, canopies and similar weather protection elements shall be installed between transom and display windows. These elements should allow for light to enter the storefront through the transom windows and allow the weather protection feature to shade the display window.
 - Awnings may be fixed or retractable.
 - Awnings, canopies and other weather protection elements shall not extend across the entire facade. Instead, individual segments shall be installed over each storefront entry or set of storefront windows and shall not extend across wall sections, across multiple windows or over columns.

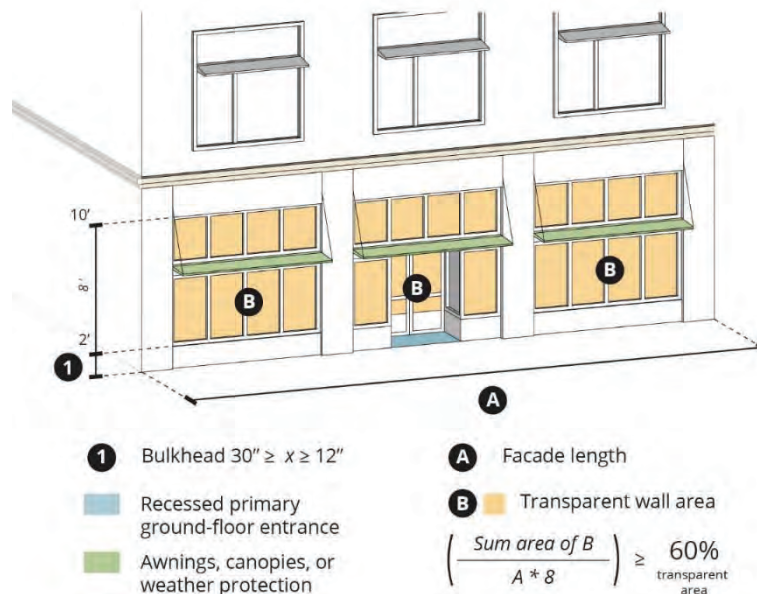
**(ii) Other Non-residential Ground Floors**

- (a) Ground floor height shall be a **minimum 14 feet floor-to-floor** or shall match the 2nd floor datum line of an abutting building.
- (b) Transparency shall include a minimum 50 percent transparent glazing between 4 and 10 feet in height from sidewalk or terrace grade.

THERE SHOULD BE SOME FLEXIBILITY FOR PROGRAM NEEDS OR NAVIGATING GRADE CHANGES FRONT TO BACK. CONSIDER A RANGE, (IE 12'-15' FLOOR TO FLOOR) RATHER THAN A STRICT MINIMUM.

Page: 21

 Number: 1 Author: elaine Subject: Highlight Date: 12/5/2020 3:22:33 PM
minimum 14 feet floor-to-floor

 Number: 2 Author: elaine Subject: Highlight Date: 12/5/2020 3:22:43 PM
6 feet wide and
4 feet

 Number: 3 Author: elaine Subject: Highlight Date: 12/5/2020 2:44:27 PM
a minimum 14 feet floor-to-floor

 Number: 4 Author: elaine Subject: Text Box Date: 12/5/2020 2:46:32 PM

THERE SHOULD BE SOME FLEXIBILITY FOR PROGRAM NEEDS OR NAVIGATING GRADE CHANGES FRONT TO BACK. CONSIDER A RANGE, (IE 12'-15' FLOOR TO FLOOR) RATHER THAN A STRICT MINIMUM.

80 SF SEEMS LARGE FOR SMALL SITES, MAKE SURE THIS IS CONSISTENT WITH 18.24.040(B)ii PRIMARY BUILDING ENTRY

1

- (c) Primary entries shall include weather protection that is a minimum 10 feet wide and 8 feet deep by recessing the entry, providing an awning or using a combination of these methods.

(iii) Residential Ground Floors

- (a) Finished Floor Height: Units on ground floors shall have a finished floor height at a minimum two feet above average back of sidewalk height for the associated façade.
- (b) Primary entries shall include weather protection that is a minimum 4 feet wide and 4 feet deep by recessing the entry, providing an awning or using a combination of these methods.

THE 25% ON NARROW 100' SITES MAY BE IMPOSSIBLE TO MEET. GARAGES ARE TYPICALLY 20' WIDE FOR INGRESS AND EGRESS, THERE MAY ALSO BE UTILITY ACCESS (ELECTRICAL ROOMS, TRASH ROOMS, BACKFLOW PREVENTERS,) IN ADDITION TO GARAGE ACCESS,

3

(E) Parking/Loading/Utilities

- (i) Entry Size: No more than 25% of the site frontage facing a street should be devoted to garage openings, carports, surface parking, loading entries, or utilities access (on sites with less than 100 feet of frontage, no more than 25 feet)
- (ii) Above grade structured parking levels facing a public right-of-way or publicly accessible open space/path shall be lined with commercial or habitable uses with a minimum depth of 20 feet.
- (iii) Partially sub-grade parking not exceeding six feet in height above abutting grade at back of sidewalk shall be screened with features meeting the standards of section 18.24.110 Visual, Screening, and Landscaping.

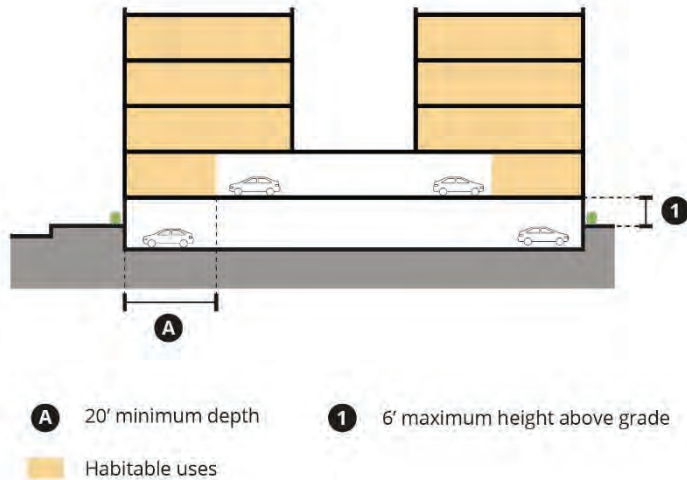

Page: 22

-
- ☰ Number: 1 Author: elaine Subject: Text Box Date: 12/5/2020 3:22:06 PM
80 SF SEEMS LARGE FOR SMALL SITES, MAKE SURE THIS IS CONSISTENT WITH 18.24.040(B)ii PRIMARY BUILDING ENTRY
-
- 📄 Number: 2 Author: elaine Subject: Highlight Date: 12/5/2020 2:46:48 PM
10 feet wide
and 8 feet deep by recessing the entr
-
- ☰ Number: 3 Author: elaine Subject: Text Box Date: 12/5/2020 3:21:36 PM
THE 25% ON NARROW 100' SITES MAY BE IMPOSSIBLE TO MEET. GARAGES ARE TYPICALLY 20' WIDE FOR INGRESS AND EGRESS, THERE MAY ALSO BE UTILITY ACCESS (ELECTRICAL ROOMS, TRASH ROOMS, BACKFLOW PREVENTERS,) IN ADDITION TO GARAGE ACCESS,
-
- 📄 Number: 4 Author: elaine Subject: Highlight Date: 12/5/2020 2:51:26 PM
25% of the site frontage facing a street should be devoted to
garage openings, carports, surface parking, loading entries, or utilities access (on sites
with less than 100 feet of frontage, no more than 25 feet)
-
- 📄 Number: 5 Author: elaine Subject: Highlight Date: 12/5/2020 2:51:20 PM
20 feet.

18.24.070 Residential Entries

(A) Intent

Private entries into ground floor residential units shall be designed to provide:

- human-scaled detailing
- enhanced pedestrian experience
- transition between public and private space
- spaces for residents to gather and spend time outdoors
- resident privacy

(B) Ground floor unit entries

(i) Where ground floor residential unit entries are required, one or more of the following entry types shall be provided:

(a) Stoop:

1. Stoops shall provide entry access for a maximum of two units.; and
2. Stoop entry landings shall be a minimum 4 feet in depth; and
3. The maximum stoop height from the back of sidewalk grade shall be 5 feet.



BE CONSISTENT WITH 18.10.024.(C)ii WHICH SAYS 36 SF AND MIN 5' DIMENSION

(b) Porch:

1. Porches shall provide entry access for a maximum of one unit; and
2. Porches shall be large enough so a 5-foot by 6-foot square can fit inside of a porch for each unit; and
3. The maximum porch floor height from the back of sidewalk grade shall be 5 feet.



Page: 23

 Number: 1 Author: elaine Subject: Highlight Date: 12/5/2020 3:27:46 PM

Private entries into ground floor residential units shall be designed to provide:
human-scaled detailing
enhanced pedestrian experience
transition between public and private space
spaces for residents to gather and spend time outdoors
resident privacy

 Number: 2 Author: elaine Subject: Highlight Date: 12/5/2020 3:27:52 PM

 Number: 3 Author: elaine Subject: Text Box Date: 12/5/2020 2:55:19 PM

BE CONSISTENT WITH 18.10.024.(C)ii WHICH SAYS 36 SF AND MIN 5' DIMENSION

 Number: 4 Author: elaine Subject: Highlight Date: 12/5/2020 2:52:06 PM

6-foot by 6-foot square can fit inside of a
porch for each unit

(c) Terrace:

1. A Terrace may serve multiple unit entries; and
2. The maximum Terrace height shall be 30 inches above the grade of the back of the adjacent sidewalk or accessway; and
3. Walls, fences and hedges on Terraces shall be a maximum of 42 inches tall and have a minimum transparency of 40 percent.

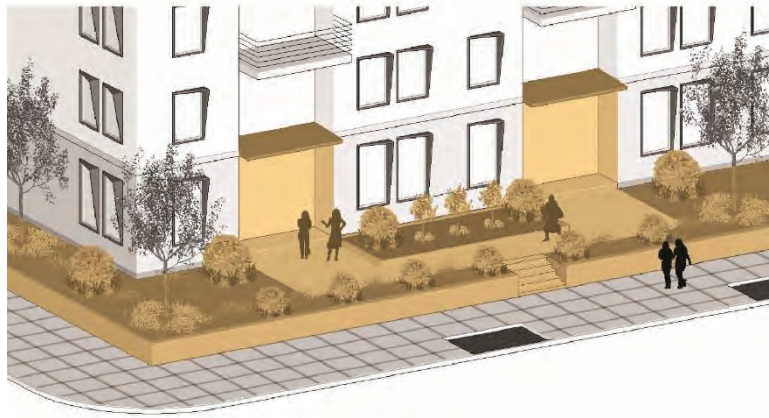
**(d) Frontage Court:**

1. A Frontage Court may serve multiple unit entries; and
2. The minimum Frontage Court width along a primary frontage shall be 25 feet; and
3. The maximum Frontage Court width along a primary frontage shall be 50 percent of the facade length or 80 feet, whichever is less; and
4. The minimum Frontage Court depth shall be 25 feet; and
5. The maximum Frontage Court depth shall be 50 feet or a ratio not to exceed 2:1 depth to width.



 Number: 1 Author: elaine Subject: Highlight Date: 12/5/2020 2:55:59 PM
30 inches

18.24.080 Open Space

1 (A) Intent

To ensure that residents and visitors have access to usable open space and common facilities that provide recreational opportunities, promote a healthy environment, and enhance the experience of living in Palo Alto. Common and private open spaces should include the following characteristics:

- Be integrated into the site access and building circulation strategy
- Be generous in dimension to provide usable space
- Provide landscape elements that will support the health of the plants and enhance the character of place
- Promote public health
- Be located to provide easy access to private and common building areas
- Promote sustainable practices and opportunities for green infrastructure
- Promote community safety through eyes on the street

(B) Private Open Space

Private Open Spaces shall be immediately accessible from each residential unit, provide direct visible access to the sky, protect from weather, and take advantage of possible views. Private Open Spaces shall meet the following standards:

- (a) Minimum dimension of six feet by six feet.
- (b) Minimum clear height dimension of 8'-6" feet
- (c) Be accessed directly from a residential unit
- (d) Balconies shall not be located within the daylight plane
- (e) Notwithstanding subsection (a), ground floor patios shall meet the following minimum requirements:

- 2 1. RM-20 and RM-30 districts, Minimum dimension of eight feet by eight feet and 3 100 square feet of area for at least 75% of the area
2. RM-40 districts, Minimum dimension of six feet by six feet and 4 30 square feet of area for at least 75% of the area
3. [TO COME: Regulating height above the ground-floor/setback from the street to ensure privacy/usability]

THIS MAKES NO SENSE. IS THERE A DIAGRAM?

(C) Common Open Space

Common Open Space shall meet the following standards:

1. Minimum dimension of 12 feet.
2. Minimum of 60% of area open to the sky free of permanent weather protection or encroachments
3. Notwithstanding subsection (1), courtyards enclosed on four sides shall have a minimum dimension of 40 feet and have a minimum courtyard width to building height ratio of 1:1.25
4. Include places to sit
5. A minimum 20% of landscaping

Number: 1 Author: elaine Subject: Highlight Date: 12/5/2020 3:29:15 PM

(A) Intent

To ensure that residents and visitors have access to usable open space and common facilities that provide recreational opportunities, promote a healthy environment, and enhance the experience of living in Palo Alto. Common and private open spaces should include the following characteristics:

Be integrated into the site access and building circulation strategy

Be generous in dimension to provide usable space

Provide landscape elements that will support the health of the plants and enhance the character of place

Promote public health

Be located to provide easy access to private and common building areas

Promote sustainable practices and opportunities for green infrastructure

Promote community safety through eyes on the street

Number: 2 Author: elaine Subject: Text Box Date: 12/5/2020 3:20:40 PM

THIS MAKES NO SENSE. IS THERE A DIAGRAM?

Number: 3 Author: elaine Subject: Highlight Date: 12/5/2020 2:59:25 PM

100 square feet of area for at least 75% of the area

Number: 4 Author: elaine Subject: Highlight Date: 12/5/2020 2:59:20 PM

80 square feet of
area for at least 75% of the are

JOURNAL

The Shape of Three Cities

Nearly every community, if not all, in the San Francisco Bay Area have adopted development standards codified in their municipal codes as site development regulations and guidelines, precise plans or specific plans. Typically drafted by a team of design consultants, city boards and community stakeholders, these development standards are viewed as the map or blueprint for the shape of the community's built environment and vary from community to community.

On the Peninsula, three contiguous city's have very different development standards based either on building form, architectural style or design compatibility. Each commercial planning application is evaluated in terms of the specific requirements of these different standards. City planning staff, planning commissions and architectural review boards apply these standards to determine if a proposed project is compliant. Some standards are more objective, formulaic and easier to use than others that require a deeper understanding of the subjective nature of architecture.

Form based development standards take a measured, objective approach to design evaluation. The building must be no taller than the height limit, it must setback from the property line a prescribed distance and step back from the street above a certain height; it must be punctuated by rhythms of minor and major building modulations with precise widths and depths that extend to the sky, as well as, building breaks that create open space between building mass. Ground floors must have windows set back a defined number of inches from the exterior wall surface, not be longer than a certain dimension and comprise a certain percentage of the wall area or the project is non-compliant. The architectural style is not dictated thus allowing for many architectural expressions, provided all criteria in the form based standards are satisfied and checked off by planning staff.

Style based development standards take a formulaic, controlled approach to design evaluation. This method dictates not only some form based standards discussed above like height, setback and open space but go even further to determine the architectural style and execution of the proposed building. Depending on the area of the community where the building is located, the designer has the option of three architectural styles for instance: Neo-classical, Mediterranean or Art Deco. Once the style is selected, the height of the building's base, building's middle (body) and cornice size and projection are all predetermined. The location, depth, proportion and pattern of the windows is dictated by the standard. How colors are applied to the building and what architectural details can be used are also not left to chance, all predetermined for the designer. Is there any design subjectivity or personal expression left? Not really, but this makes it easier for the planning staff, planning commissions and architectural review boards to evaluate the proposals and not disrupt the community.

Compatibility based development standards are more subjective but take into consideration how well the proposed building responds to the community's goals, how it addresses the sidewalk, how the building creates active pedestrian areas and how it defines or reinforces open spaces. Architectural compatibility is measured by considering the building's context, the rhythm of the street wall, the alignment of roof lines, canopies and cornices and the size, shape, proportion and location of windows and building entries. Compatibility also addresses our time, considering the market needs for certain kinds of space and the environmental and sustainability demands of our world. Compatibility does not address architectural style since different styles have co-existed since our cities began and can be mutually compatible. Evaluating a building based on a compatibility standard is much more difficult since there is no checklist of prescriptions or styles to check off, it is subjective and left up to the designer to present his or her project and demonstrate that it satisfies the standard of compatibility.

Quality design that responds to the goals, issues and problems of today is not about style based or form based site development requirements but rather compatibility should be the standard and within this framework buildings should be reviewed. It is more subjective and can take more time but the discussion that ensues between planning staff, commissions, review boards and the designers will make our communities a better place.





Architectural Review Board

Staff Report (ID # 11515)

Report Type: Action Items **Meeting Date:** 2/18/2021

Summary Title: 650 Clark Way: Creek Bank Restoration

Title: PUBLIC HEARING / QUASI-JUDICIAL. 650 Clark Way [20PLN-00134]: Recommendation on Applicant's Request for Approval of a Major Architectural Review to allow in-channel creek bank stabilization of the Children's Health Council property. The proposed project will install a live log crib wall with a rock toe within San Francisquito Creek to prevent future erosion impacts. Environmental Assessment: A Mitigated Negative Declaration (MND) was circulated from February 5, 2021 to March 7, 2021 in accordance with CEQA. Zoning District: PF (Public Facilities). For more information contact the Project Planner at Claire.raybould@Cityofpaloalto.org.

From: Jonathan Lait

Recommendation

It is recommended that the Architectural Review Board (ARB) take the following action(s):

1. Consider the Mitigated Negative Declaration and Mitigation Monitoring and Reporting Plan; and
2. Recommend approval of the proposed project to the Director of Planning and Development Services based on findings and subject to conditions of approval.

Report Summary

The subject property is occupied by the Children's Health Council (CHC); land leased from Stanford University. The CHC provides specialized education and clinical services to children and teens with autism, attention deficit hyperactivity disorder (ADHD), anxiety, depression, and other learning differences. The site is developed with two on-site schools, a therapy center, clinics for underserved families, a community education center, and an outdoor learning area/playground.

During the 2016-2017 rainy season, active erosion of the eastern embankment accelerated. This resulted in the loss of approximately 20 horizontal feet of the creek bank and 7,500 square feet of the CHC outdoor learning area. The applicant proposes to construct a log crib wall with a rock toe foundation along a 275-foot-long, 50-foot-wide linear portion of the campus bordering the creek. The project would stabilize the eroding eastern embankment of San Francisquito Creek that forms the western border of the CHC campus, while preserving and enhancing the existing stream and riparian habitat.

In 2018, the City approved installation of a shear pin wall behind the top of bank to protect the property at 650 Clark from the eminent threat of landslide failure. The shear pin wall provided immediate protection for areas behind the wall. However, it did not resolve ongoing erosion within the creek bank, which will continue to erode back to the shear pin wall over time. This project is intended to preempt the need for future hardscape along this portion of the creek bank to reinforce the shear pin wall. Such hardscape would not be supported by the City or other regulatory agencies. The proposed project would prevent future erosion along this portion of the creek bank with a more sustainable, bioengineered approach.

Background

Project Information

Owner:	Leland Stanford Junior University Board of Trustees
Ecologist:	WRA Environmental Consultants
Applicant:	Children's Health Council (CHC)
Legal Counsel:	Not Applicable

Property Information

Address:	650 Clark Way
Neighborhood:	Not Applicable (Stanford Land)
Lot Dimensions & Area:	Irregular lot lines; 763,219 sf (17.521 Acres)
Housing Inventory Site:	Not Applicable
Located w/in a Plume:	Not Applicable
Protected/Heritage Trees:	Two protected Coast Live Oaks within the work area would be removed; No heritage trees
Historic Resource(s):	No historic resources present; see discussion of archeological resources below.
Existing Improvement(s):	51,900 sf; two stories; 1998]
Existing Land Use(s):	Mixed-use (Institutional/Residential)
Adjacent Land Uses & Zoning:	North: R1S Zoning within Menlo Park (single family residential land uses) West: San Francisquito Creek (Streamside Open Space land use) East: PF Zoning (Children's Health Council site); PC-4426 Zoning (Major Institution/Special Facilities land uses [Vi Palo Alto Senior Assisted Living and Sand Hill School])

South: RM-30(D) Zoning (multi-family residential land use [Stanford West Apartments])

Aerial View of Property:

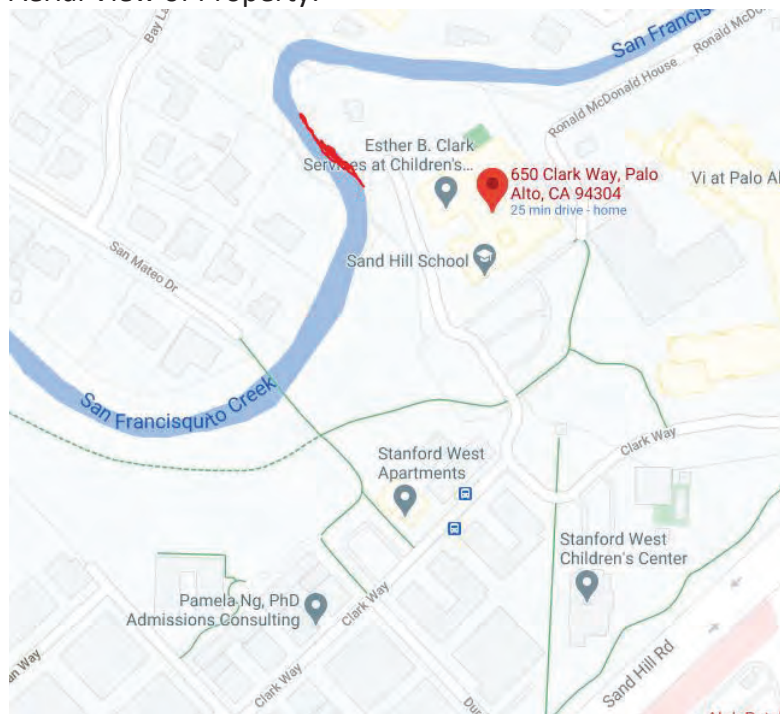

Source: Google Images

Land Use Designation & Applicable Plans

Zoning Designation:	Public Facility
Comp. Plan Designation:	Major Institution/Special Facility (MISP) and Streamside Open Space (SOS)
Context-Based Design Criteria:	Not Applicable
Downtown Urban Design Guide:	Not Applicable
South of Forest Avenue Coordinated Area Plan:	Not Applicable
Baylands Master Plan:	Not Applicable
El Camino Real Design Guidelines (1976 / 2002):	Not Applicable
Proximity to Residential Uses or Districts (150'):	Single-family residential (~50 feet within Menlo Park); Stanford West Apartments and Vi at Palo Alto (Senior Assisted Living Center) are more than 500 feet from the work area.
Located w/in the Airport Influence Area:	Not Applicable

Prior City Reviews & Action

City Council:	None
PTC:	None
HRB:	None
ARB:	None

The City approved a Minor Architectural Review application in September 2018 to allow installation of a below-grade shear pin wall behind the top of bank. The shear pin wall design was based on the Geotechnical Report prepared by Cotton Shires and Associates in 2017. The purpose of the wall was to stabilize the property behind the eroding bank. This prevented the clear and imminent danger of further loss of property, including key site infrastructure, and ensured user safety. The shear pin wall provided immediate protection to the property, by protecting land and infrastructure behind the wall. However, it did not resolve long-term erosion along this portion of the property at the toe of the bank. The proposed project would address this continued concern.

Project Description

The applicant proposes to construct a log crib wall with a rock toe foundation. This will stabilize the eroding eastern embankment of San Francisquito Creek that forms the western border of the CHC campus, while preserving and enhancing the existing stream and riparian habitat. A project location map is included in Attachment A. The applicant's project description is included in Attachment D and a link to the project plans is included in Attachment E.

The crib wall would be built using stacked layers of 1.5-foot-diameter logs and rootwads (tree trunks with roots attached) installed at a 1:1 slope. The crib wall includes several levels:

- The first level of the crib wall would utilize tie-back logs braced to absorb the impact of the streamflow and 13 rootwads, or large diameter coarse woody debris, spaced approximately 10 feet apart along the natural pool of the creek to provide interstitial spaces for fish habitat.
- The second layer of the crib wall includes two rows of logs parallel to the streamflow connecting the first layer of tie-back logs. Each log would be pinned to the logs below using steel bolts, nuts, and washers to provide redundancy in structural loading. Helical anchors would also be driven into the soil and connected to the crib wall to prevent the overall structure from moving laterally.
- The third layer of crib wall would be similar to the first layer, using tie-back logs, and the fourth layer would connect to the tie-back logs underneath. Logs would be placed until the desired height of bank protection is achieved, approximately five to 10 feet above the creek bed.

Above the crib wall, the upper channel embankment would be graded to a maximum horizontal to vertical slope of 2:1. The proposed design calls for a rock toe foundation to be constructed at the base of the slope, under the first row of the crib wall, using imported clean boulder, cobble, and engineered fill material. The purpose of the rock toe foundation is to serve as the base for

the aforementioned crib wall, which prevents: (1) movement of the channel bottom, and (2) channel flows from undercutting the crib wall.

Requested Entitlements, Findings and Purview:

The following discretionary applications are being requested:

- Architectural Review – Major (AR): The process for evaluating this type of application is set forth in PAMC 18.77.070. AR applications are reviewed by the ARB and recommendations are forwarded to the Planning & Development Services Director for action within five business days of the Board’s recommendation. Action by the Director is appealable to the City Council if filed within 14 days of the decision. AR projects are evaluated against specific findings. All findings must be made in the affirmative to approve the project. Failure to make any one finding requires project redesign or denial. Draft findings for approval are provided in Attachment B.

Analysis¹

As summarized herein, staff has analyzed the project for consistency with the City’s Zoning Ordinance, the Comprehensive Plan, and the Architectural Review findings. Staff finds the project to be consistent with the requirements, goals, policies in the applicable regulations, plans, and findings for approval.

Zoning Compliance²

Staff has performed a detailed review of the proposed project’s consistency with applicable zoning standards. Because the project does not include construction of any buildings, a detailed analysis of the project’s consistency with development standards is not applicable to the design. However, the project complies with the intent of the zoning ordinance in that it proposes a bioengineered design, which will prevent the need for future, less sustainable measures (e.g. shotcrete) to stabilize the creek bank. There are no design guidelines applicable to the proposed project and the project is not subject to any interim ordinances or moratoriums. Therefore, the project is consistent with the zoning ordinance.

Consistency with the Comprehensive Plan, Area Plans and Guidelines³

The Comprehensive Plan includes Goals, Policies, and Programs that guide the physical form of the City. The Comprehensive Plan provides the basis for the City’s development regulations and is used by City staff to regulate building and development and make recommendations on

¹ The information provided in this section is based on analysis prepared by the report author prior to the public hearing. The Architectural Review Board in its review of the administrative record and based on public testimony may reach a different conclusion from that presented in this report and may choose to make alternative findings. A change to the findings may result in a final action that is different from the staff recommended action in this report.

² The Palo Alto Zoning Code is available online: http://www.amlegal.com/codes/client/palo-alto_ca

³ The Palo Alto Comprehensive Plan is available online: <http://www.cityofpaloalto.org/gov/topics/projects/landuse/compplan.asp>

projects. Further, ARB Finding #1 requires that the design be consistent and compatible with applicable elements of the Palo Alto Comprehensive Plan.

The project site has a split Comprehensive Plan land use designation of Streamside Open Space (SOS) and Major Institutions/Special Facilities (MISP). The proposed work area is located within the area of the site designated as SOS. This designation is intended to preserve and enhance corridors of riparian vegetation along streams.

The project is consistent with the policies in the Comprehensive Plan and therefore fulfills the goals of the Plan as well. A detailed review of the project's consistency with the Comprehensive Plan is provided in the findings for approval in Attachment B.

Multi-Modal Access & Parking

The proposed project includes work within the stream bank to reduce underscoring along the eastern embankment of San Francisquito Creek where it abuts 650 Clark Way. Operation of the proposed project would not affect multi-modal access or parking. During construction, the proposed project would require staging activities. These activities would occur within the project site. Activities would be temporary and would not affect access to the project site or parking at the site.

Consistency with Application Findings

Staff finds that the project is consistent with Architectural Review findings. The project is specifically designed to provide long-term creek stabilization using a creek bank design that incorporates native vegetation and improves habitat for wildlife along this bank while also avoiding and protecting known cultural resources in place.

Trees and Vegetation

The project includes removal of five trees, including two protected Coast Live Oak trees, two California buckeyes, and one red willow. Both of the protected trees to be removed have been significantly undercut already and their roots exposed. Without the project, erosion beneath these trees would likely continue until the trees fall into the creek.

These five trees will be replaced with 15 new trees and willow cuttings as documented in the project plans. All tree plantings are native. They have been selected and located to ensure that the establishment of the new trees is either incorporated into the revegetation plan to provide long-term bank stability or the trees are otherwise set back from the bank to ensure that the water needed to establish these new trees would not affect the stability of the creek bank.

Environmental Review

The subject project has been assessed in accordance with the authority and criteria contained in the California Environmental Quality Act (CEQA), the State CEQA Guidelines, and the

environmental regulations of the City. Specifically, the City, acting as the lead agency, circulated an Initial Study/Mitigated Negative Declaration (IS/MND) on February 5, 2021 for a 30-day public review period, which ends on March 7, 2021. A link to the IS/MND is included in Attachment E. Following the public review period, the City will consider all comments received during the circulation period and publish a Final IS/MND prior to issuing a decision on the proposed project.

The IS/MND identifies impacts related to biological resources and cultural resources and identifies mitigation measures to reduce those impacts to a less than significant level. If the City adopts the IS/MND and approves the proposed project, additional permits will be required from regulatory agencies. The agencies described in the below report section will serve as responsible agencies. These agencies would be responsible for issuing permits prior to construction of the proposed project.

Public Notification, Outreach & Comments

The Palo Alto Municipal Code requires notice of this public hearing be published in a local paper and mailed to owners and occupants of property within 600 feet of the subject property at least ten days in advance. Notice of a public hearing for this project was published in the *Daily Post* on February 5, which is 13 days in advance of the meeting. Postcard mailing occurred on February 4, which is 14 days in advance of the meeting. Letters describing the project in further detail were mailed directly to property owners downstream of the proposed project along the west bank (Menlo Park) in January 2021. These property owners were also included in the mailing for the hearing. As of the writing of this report, no comments have been received on the proposed project.

Since early 2019, the applicant has coordinated extensively with multiple agencies:

- Water resource agencies (including the U.S. Army Corps of Engineers, Regional Water Quality Control Board, the San Francisco Creek Joint Powers Authority (SFCJPA), and Valley Water),
- Wildlife agencies (National Marine Fishery Services [NMFS], California Department of Fish and Wildlife, and U.S. Fish and Wildlife Service),
- Archeological experts and tribes.

The applicant obtained early feedback on the proposed design and prepared a design that would satisfy the regulatory requirements of all of these agencies, experts, and tribes, as well as the City, prior to filing this application.

The SFCJPA has reviewed the proposed project and, although they do not provide formal feedback on such projects, they did not request any changes to the design. Valley Water's hydrologists have reviewed the approved the hydraulic analysis. Valley Water's biologists have also peer reviewed the replanting plan and found it acceptable.

The applicant will be required to obtain subsequent permits or approvals for this project, including, but not limited to:

- A Lake and Streambed Alteration Agreement (LSAA) from CDFW,
- 404 and 401 certifications from the USACE and RWQCB, respectively,
- Section 7 consultation with USFWS , and
- Section 106 consultation with the State Historic Preservation Office (SHPO) as part of the process of obtaining permits from a federal agency.

Alternative Actions

In addition to the recommended action, the Architectural Review Board may:

1. Approve the project with modified findings or conditions;
2. Continue the project to a date (un)certain; or
3. Recommend project denial based on revised findings.

Report Author & Contact Information

Claire Raybould, AICP, Senior Planner
 (650) 329-2116

Claire.Raybould@cityofpaloalto.org

ARB⁴ Liaison & Contact Information

Jodie Gerhardt, AICP, Planning Manager
 (650) 329-2575

jodie.gerhardt@cityofpaloalto.org

Attachments:

- Attachment A: Location Map (PDF)
- Attachment B: ARB Findings for Approval (DOCX)
- Attachment C: Conditions of Approval (PDF)
- Attachment D: Applicant's Project Description (PDF)
- Attachment E: Link to Project Plans and Environmental Document (DOCX)

⁴ Emails may be sent directly to the ARB using the following address: arb@cityofpaloalto.org

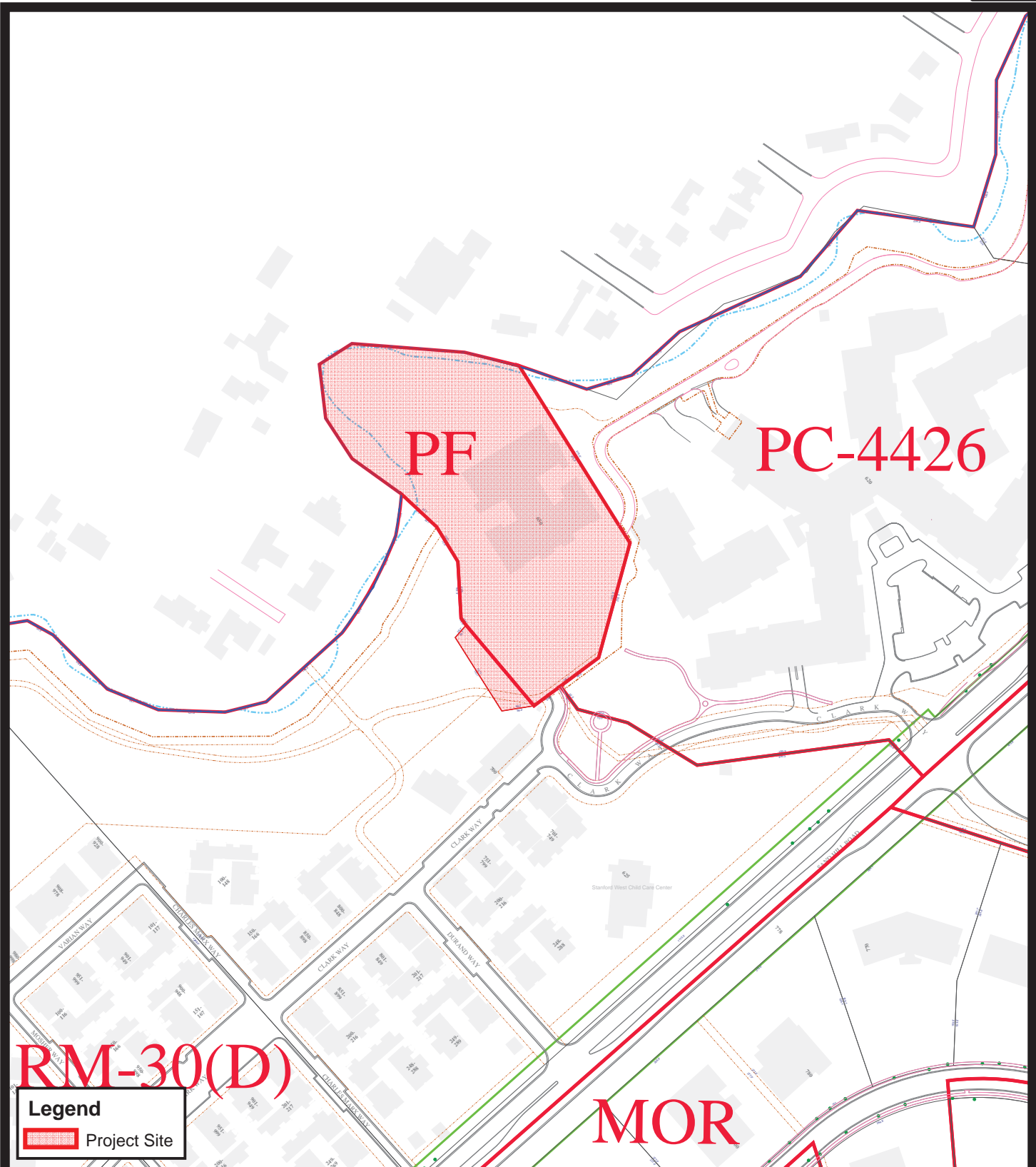

Legend
 Project Site

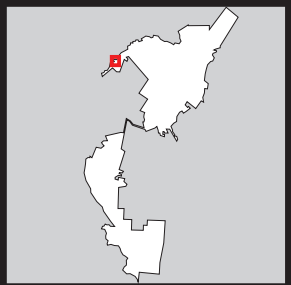
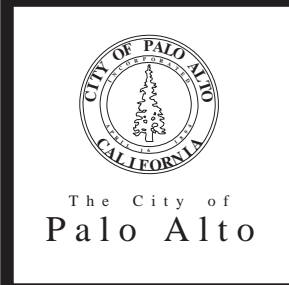

Attachment A:
Project Location

This map is a product of the
City of Palo Alto GIS

A north arrow pointing upwards and a graphic scale bar showing 0 feet to 248 feet.

ATTACHMENT B
DRAFT FINDINGS FOR APPROVAL
650 Clark Way / File No. 20PLN-00134

Section A: CEQA Findings

The Director of Planning and Community Environment (Director) makes the following findings:

1. The environmental effects of the Project have been analyzed in an Initial Study/Mitigated Negative Declaration (IS/MND) prepared in accordance with the requirements of the California Environmental Quality Act of 1970 (CEQA).
2. The IS/MND identified one or more potentially significant effects of the Project on the environment as well as mitigation measures that would reduce the significant effects to a less than significant level. The Project applicant, before public release of the draft MND, has made or agreed to make revisions to the Project that clearly mitigate the effects to a less than significant level as demonstrated through the adoption of the related Mitigation Monitoring and Reporting Program (MMRP).
3. The Director has independently reviewed and considered the Initial Study/MND, together with any public comments received during the public review process and other information in the record, prior to acting upon or approving the Project.
4. The IS/MND reflects and represents the independent judgment and analysis of the City of Palo Alto as lead agency.
5. Based on the whole record of proceedings, the Director hereby finds that there is no substantial evidence that the Project will have a significant effect on the environment, and does hereby adopt the Mitigated Negative Declaration and related Mitigation Monitoring and Reporting Program prepared for the Project.
6. The Director of Planning and Community Environment at the Director's Office at 250 Hamilton Avenue, Palo Alto, California 94301 is the custodian of records and documents of proceedings on which this decision is based.

Section B: Architectural Review Findings

The design and architecture of the proposed improvements, as conditioned, complies with the Findings for Architectural Review as required in Chapter 18.76 of the PAMC.

Finding #1: The design is consistent with applicable provisions of the Palo Alto Comprehensive Plan, Zoning Code, coordinated area plans (including compatibility requirements), and any relevant design guides.

The project is consistent with Finding #1 because:

In conformance with the following Comp Plan Goals and Policies, the project includes stabilization of the

creek bank using natural methods that will improve the habitat while also implementing a long-term solution for the protection of property, including open space area. The following table summarizes how the project is consistent with the City's Comprehensive Plan. The project is also consistent with the zoning ordinance in that a bioengineered design supports the stability and habitat improvement along this bank using a naturalized approach rather than hardscape improvements. No physical structures or modifications to existing structures are proposed. The project is not located in a coordinated area plan area.

<i>Comp Plan Goals and Policies</i>	<i>How project adheres or does not adhere to Comp Plan</i>
The Comprehensive Plan land use designation for the site is Streamside Open Space	The project proposes a bioengineered design that utilizes natural features to stabilize the creek bank within this area. Therefore, the project is consistent with this land use designation.
<i>Land Use and Community Design Element</i>	
Policy L-48: Promote high quality, creative design and site planning that is compatible with surrounding development and public spaces.	The project provides a well-designed, natural approach to stream bank stabilization in a manner that stabilizes the creek bank, protecting outdoor area and also avoids downstream impacts and impacts to ecological and archeological resources. Therefore this project promotes creative design that is compatible with its surroundings.
<i>Natural Element</i>	
Policy N-2.1: Recognize the importance of the urban forest as a vital part of the city's natural and green infrastructure network that contributes to public health, resiliency, habitat values, appreciation of natural systems and an attractive visual character which must be protected and enhanced	The project includes removal of five trees but includes replacement with 15 trees and willow cuttings. The project is designed to provide a naturalized creek bank with native vegetation and works around existing trees where they can be protected.
Policy N-3.2: Prevent the further channelization and degradation of Palo Alto's creeks.	The project avoids a future need to address creek bank stabilization with an approach that includes channelization or other measures that would degrade the habitat along the creek bank, recognizing that protection of these resources is critical to this corridor. The project includes native tree and vegetation planting that enhances the habitat while also stabilizing the creek bank
Policy N-3.4: Recognize that riparian corridors are valued environmental resources whose integrity provides vital habitat for fish, birds, plants and other wildlife, and carefully monitor and preserve these corridors.	
Policy N-3.5: Preserve the ecological value of creek corridors by preserving native plants and replacing invasive, non-native plants with native plants.	
Policy N-3.6: Discourage bank instability, erosion, downstream sedimentation, and flooding by minimizing site disturbance and nearby native vegetation removal on or near creeks and by	The project provides bank stability while avoiding downstream erosion and adds vegetation to improve stability.

<i>Comp Plan Goals and Policies</i>	<i>How project adheres or does not adhere to Comp Plan</i>
reviewing grading and drainage plans for development near creeks and elsewhere in their watersheds.	

Finding #2: The project has a unified and coherent design, that:

- a. creates an internal sense of order and desirable environment for occupants, visitors, and the general community,
- b. preserves, respects and integrates existing natural features that contribute positively to the site and the historic character including historic resources of the area when relevant,
- c. is consistent with the context-based design criteria of the applicable zone district,
- d. provides harmonious transitions in scale, mass and character to adjacent land uses and land use designations,
- e. enhances living conditions on the site (if it includes residential uses) and in adjacent residential areas.

The project is consistent with Finding #2 because:

The design of this streambank stabilization project preserves, respects, and integrates natural features. The project is specifically designed to avoid impacts to archeological resources while stabilizing the creek bank using a bioengineered design that incorporates natural material. The project preserves the feel of a natural creek bank with vegetation for residents across the creek in Menlo Park. Although two oak trees would be removed, these trees are significantly undercut already by the ongoing erosion at the property. Without this project, these trees would likely fall into the creek bank in time, creating a hazard. These trees would be replaced with new trees set back from the bank as well as small trees that are incorporated into the design. Therefore the project is consistent with this finding.

Finding #3: The design is of high aesthetic quality, using high quality, integrated materials and appropriate construction techniques, and incorporating textures, colors, and other details that are compatible with and enhance the surrounding area.

The project is consistent with Finding #3 because:

The project includes natural materials, such as logs that incorporate well into the streamside open space setting. All vegetation would be natural and is specifically designed to enhance the habitat of the area.

Finding #4: The design is functional, allowing for ease and safety of pedestrian and bicycle traffic and providing for elements that support the building's necessary operations (e.g. convenient vehicle access to property and utilities, appropriate arrangement and amount of open space and integrated signage, if applicable, etc.).

The project is consistent with Finding #4 because:

All work would occur within the bank of San Francisquito creek and therefore would have no impact during operations on the existing circulation within the area. During construction, the project would also

have no impact on bicycle/pedestrian safety; work staging areas and parking would occur within the paved areas on the private property at 650 Clark Way. No street closures or lane closures would be necessary. Emergency vehicle access would be maintained at all times. The project would provide a long-term solution to stabilize the creek bank on this property, which would help to retain the existing open space area used by children at the site.

Finding #5: The landscape design complements and enhances the building design and its surroundings, is appropriate to the site's functions, and utilizes to the extent practical, regional indigenous drought resistant plant material capable of providing desirable habitat that can be appropriately maintained.

The project is consistent with Finding #5 because:

The proposed work includes a bioengineered design that incorporates natural features and vegetation in order to stabilize the creek bank in-lieu of methods such as shotcrete, which would affect the natural environment and habitat along the bank. Therefore the proposed project provides a design that stabilizes the creek while also maintaining the natural feel of this streamside open space, consistent with the surrounding area. The project includes only native plantings, consistent with finding #5.

Finding #6: The project incorporates design principles that achieve sustainability in areas related to energy efficiency, water conservation, building materials, landscaping, and site planning.

The project is consistent with Finding #6 because:

The project utilizes natural materials to naturally stabilize the creek bank. The project does not include any energy use following construction and the project would utilize water only as necessary to establish the vegetation.

ATTACHMENT C
CONDITIONS OF APPROVAL

650 Clark Way
20PLN-00134

PLANNING DIVISION

1. CONFORMANCE WITH PLANS. Construction and development shall conform to the approved plans entitled, "Children's Health Council Creek Bank Stabilization project: Phase II Palo Alto, California," stamped as received by the City on February 1, 2021 on file with the Planning Department, 250 Hamilton Avenue, Palo Alto, California except as modified by these conditions of approval.
2. MITIGATION MONITORING AND REPORTING PROGRAM. The Mitigation Monitoring and Reporting Program associated with the project and attached here in Exhibit A is incorporated by reference and all mitigation measures shall be implemented as described in such document.
3. GRADING PERMIT. Apply for a grading permit and meet any and all conditions of the Planning, Water Quality, Utilities, and Public Works Departments.
4. BUILDING PERMIT PLAN SET. A copy of this approval with conditions shall be printed on the second page of the plans submitted for building permit.
5. PROJECT ARBORIST. The property owner shall retain a certified arborist to ensure the project conforms to all Planning and Urban Forestry conditions related to landscaping/trees, as shown in the approved plan set.
6. TREE PROTECTION FENCING. Tree protection fencing shall be required to protect trees that are to remain during construction.
7. NUISANCES AND NOISE. Noise-producing equipment shall not exceed the maximum level established in the PAMC Chapter 9.10.
8. PLANNING FINAL INSPECTION. A Planning Division Final inspection will be required to determine substantial compliance with the approved plans prior to the scheduling of a Building Division final. Any revisions during the building process must be approved by Planning, including but not limited to; materials, fenestration and hard surface locations. Contact your Project Planner, Claire Raybould, to schedule this inspection.
9. LANDSCAPE MAINTENANCE. All landscape material shall be well maintained and replaced if necessary, to the satisfaction of the Urban Forester and Director of Planning.

10. INDEMNITY: To the extent permitted by law, the Applicant shall indemnify and hold harmless the City, its City Council, its officers, employees and agents (the “indemnified parties”) from and against any claim, action, or proceeding brought by a third party against the indemnified parties and the applicant to attack, set aside or void, any permit or approval authorized hereby for the Project, including (without limitation) reimbursing the City for its actual attorneys’ fees and costs incurred in defense of the litigation. The City may, in its sole discretion, elect to defend any such action with attorneys of its own choice.
11. PERMIT EXPIRATION. The project approval shall be valid for a period of one year from the original date of approval. In the event a grading permit, if applicable, is not secured for the project within the time limit specified above, the approval shall expire and be of no further force or effect. A written request for a one-year extension shall be submitted prior to the expiration date in order to be considered by the Director of Planning and Development Services.

PUBLIC WORKS ENGINEERING

12. The project will be required to prepare and submit an Excavation & Grading Permit to Public Works Engineering per PAMC 16.28

PUBLIC WORKS URBAN FORESTRY SECTION

PRIOR TO DEMOLITION, BUILDING OR GRADING PERMIT ISSUANCE

13. TREE DAMAGE. Tree Damage, Injury Mitigation and Inspections apply to Contractor. Reporting, injury mitigation measures and arborist inspection schedule (1-5) apply pursuant to TTM, Section 2.20-2.30. Contractor shall be responsible for the repair or replacement of any publicly owned or protected trees that are damaged during the course of construction, pursuant to Title 8 of the Palo Alto Municipal Code, and city Tree Technical Manual, Section 2.25.
14. GENERAL. The following general tree preservation measures apply to all trees to be retained: No storage of material, topsoil, vehicles or equipment shall be permitted within the tree enclosure area. The ground under and around the tree canopy area shall not be altered. Trees to be retained shall be irrigated, aerated and maintained as necessary to ensure survival.
15. EXCAVATION RESTRICTIONS APPLY (TTM, Sec. 2.20 C & D). Any approved grading, digging or trenching beneath a tree canopy shall be performed using ‘air-spade’ method as a preference, with manual hand shovel as a backup. For utility trenching, including sewer line, roots exposed with diameter of 1.5 inches and greater shall remain intact and not be damaged. If directional boring method is used to tunnel beneath roots, Trenching and Tunneling Distance, shall be printed on the final plans to be implemented by Contractor.
16. TREE PROTECTION VERIFICATION. Prior to any site work verification from the contractor that the required protective fencing is in place shall be submitted to the Urban Forestry Section. The fencing shall contain required warning sign and remain in place until final inspection of the project.

17. **BUILDING PERMIT SUBMITTAL- PROJECT ARBORIST CERTIFICATION LETTER.** Prior to submittal for staff review, attach a Project Arborist Certification Letter that he/she has; (a) reviewed the entire building permit plan set submittal and, (b) affirm that ongoing Contractor/Project Arborist site monitoring inspections and reporting have been arranged with the contractor or owner (see Sheet T-1) and, (c) understands that design revisions (site or plan changes) within a TPZ will be routed to Project Arborist/Contractor for review prior to approval from City.
18. **PLAN SET REQUIREMENTS.** The final Plans submitted for building permit shall include the following information and notes on relevant plan sheets:
- a. **SHEET T-1, BUILDING PERMIT.** The building permit plan set will include the City's full-sized, Sheet T-1 (Tree Protection-it's Part of the Plan!), available on the Development Center website at <http://www.cityofpaloalto.org/civicax/filebank/documents/31783>. The Applicant shall complete and sign the Tree Disclosure Statement and recognize the Project Arborist Tree Activity Inspection Schedule. Monthly reporting to Urban Forestry/Contractor is mandatory. (Insp. #1: applies to all projects; with tree preservation report: Insp. #1-7 applies)
 - b. **The Tree Preservation Report (TPR).** All sheets of the Applicant's TPR approved by the City for full implementation by Contractor, shall be printed on numbered Sheet T-1 (T-2, T-3, etc) and added to the sheet index.
 - c. **Plans to show protective tree fencing.** The Plan Set (esp. site, demolition, grading & drainage, foundation, irrigation, tree disposition, utility sheets, etc.) must delineate/show the correct configuration of Type I, Type II or Type III fencing around each Regulated Tree, using a bold dashed line enclosing the Tree Protection Zone (Standard Dwg. #605, Sheet T-1; City Tree Technical Manual, Section 6.35-Site Plans); or by using the Project Arborist's unique diagram for each Tree Protection Zone enclosure.

WATER QUALITY DIVISION

19. The project will comply with the City's Municipal Ordinance Chapter 16/09 for Stormwater Management.

UTILITIES - WATER, GAS, WASTEWATER

20. Construction equipment may not block access to electrical utilities infrastructure

Exhibit A:
Mitigation Monitoring and Reporting Program



MITIGATION MONITORING + REPORTING PROGRAM

PROJECT NAME	Children’s Health Council San Francisquito Creek Bank Stabilization Project – Phase II	APPLICATION NUMBER	20PLN-00134
APPLICANT AGREEMENT		DATE	[2/5/2021]
APPROVED BY			
APPLICANT/OWNER	Children’s Health Council 650 Clark Way Palo Alto, CA 94304		

The Mitigated Negative Declaration (MND) for the Children’s Health Council San Francisquito Creek Bank Stabilization Project – Phase II project identifies the mitigation measures that will be implemented to reduce the impacts associated with the project. The California Environmental Quality Act (CEQA) was amended in 1989 to add Section 21081.6, which requires a public agency to adopt a monitoring and reporting program for assessing and ensuring compliance with any required mitigation measures applied to proposed development. As stated in section 21081.6(a)(1) of the Public Resources Code:

... the public agency shall adopt a reporting or monitoring program for the changes made to the project or conditions of project approval, adopted in order to mitigate or avoid significant effects on the environment.

Section 21081.6 also provides general guidelines for implementing mitigation monitoring programs and indicates that specific reporting and/or monitoring requirements, to be enforced during project implementation, shall be defined as part of adopting an MND.

The mitigation monitoring table lists those mitigation measures that would be included as conditions of approval for the project. To ensure that the mitigation measures are properly implemented, a monitoring program has been devised which identifies the timing and responsibility for monitoring each measure.



DRAFT MITIGATION MONITORING + REPORTING PROGRAM

Environmental Impact	Mitigation Measure	Responsible for Implementation	Timing of Compliance	Oversight of Implementation
AIR QUALITY				
<p>Impact AIR-3.1</p>	<p>MM AIR-3.1, Best Management Practices</p> <p>During any construction period ground disturbance, the project applicant shall ensure that the project contractor implements measures to control dust and exhaust. Implementation of the measures recommended by the Bay Area Air Quality Management District (BAAQMD) and listed below would reduce the air quality impacts associated with grading and new construction to a less-than-significant level. The contractor shall implement the following Best Management Practices that are required of all projects:</p> <ul style="list-style-type: none"> •All exposed surfaces (e.g., parking areas, staging areas, soil piles, graded areas, and unpaved access roads) shall be watered two times per day. •All haul trucks transporting soil, sand, or other loose material off-site shall be covered. •All visible mud or dirt track-out onto adjacent public roads shall be removed using wet power vacuum street sweepers at least once per day. The use of dry power sweeping is prohibited. •All vehicle speeds on unpaved roads shall be limited to 15 miles per hour (mph). •All roadways, driveways, and sidewalks to be paved shall be completed as soon as possible. Building pads shall be laid as soon as possible after grading unless seeding or soil binders are used. •Idling times shall be minimized by either shutting 	<p>Project applicant and contractors implementing the project.</p>	<p>Prior to and during any construction activities, as specified</p>	<p>City’s Planning and Development Services (PDS) Department</p>

Environmental Impact	Mitigation Measure	Responsible for Implementation	Timing of Compliance	Oversight of Implementation
	<p>equipment off when not in use or reducing the maximum idling time to five minutes (as required by the California airborne toxics control measure Title 13, Section 2485 of California Code of Regulations [CCR]). Clear signage shall be provided for construction workers at all access points.</p> <ul style="list-style-type: none"> •All construction equipment shall be maintained and properly tuned in accordance with manufacturer’s specifications. All equipment shall be checked by a certified mechanic and determined to be running in proper condition prior to operation. •Post a publicly visible sign with the telephone number and person to contact at the City of Palo Alto regarding dust complaints. This person shall respond and take corrective action within 48 hours. The BAAQMD’s phone number shall also be visible to ensure compliance with applicable regulations. <p>MM AIR-3.2, Low-DPM or Zero Emission Equipment</p> <p>The project shall use equipment that has low diesel particulate matter (DPM) or zero emissions, and implement the following measures:</p> <ul style="list-style-type: none"> •All mobile diesel-powered off-road equipment larger than 25 horsepower and operating on the site for more than two days shall meet EPA particulate matter emissions standards for Tier 4 or use engines meeting the Tier 2 or 3 standards that include particulate matter emissions control equivalent to the California Air Resources Board (CARB) Level 3 Verified Diesel Emission Control Strategy (VDEC) devices. Alternatively (or in combination), the use of alternatively-fueled or electric equipment (i.e., non-diesel) would be 	<p>Project applicant and contractors implementing the project.</p>	<p>Prior to and during all construction activities</p>	<p>City’s PDS Department</p>

Environmental Impact	Mitigation Measure	Responsible for Implementation	Timing of Compliance	Oversight of Implementation
	<p>consistent with this requirement.</p> <ul style="list-style-type: none"> •Avoid staging of construction equipment near portions of the site that are adjacent to residences. 			

BIOLOGICAL RESOURCES

Impact BIO-1.1	<p>MM BIO-1.1, Fish Rescue</p> <p>If dewatering is required, a National Marine Fisheries Service (NMFS)- and United States Fish and Wildlife Service (USFWS)-approved biologist shall lead a fish rescue to capture and relocate any steelhead from within the work area prior to the start of work. The biologist shall be on-site during all activities that may result in take of steelhead or California red-legged frogs (CRLF). Additionally:</p> <ul style="list-style-type: none"> •If habitat is available, any captured steelhead shall be relocated immediately downstream of the work area. If suitable habitat is not available, any steelhead shall be released at the perennial pool below Searsville Dam. •If a fish rescue is required, the NMFS- and USFWS- approved biologist shall lead the fish rescue to capture and relocate any steelhead from within the work area prior to the start of work. •A bypass shall be installed to route flows around the work area either via diversion into another portion of the extant channel which is outside of the work area footprint, or via a pipe, hose, or similar structure. •Any pumps used for the project shall be screened according to NMFS criteria for salmonid streams until the area has been cleared by a NMFS- and USFWS-approved biologist. •Any water actively pumped out of the work area (e.g. removal of groundwater seepage) shall (at minimum) pass through a gravel bucket or filter sock to lower turbidity before waters are allowed to reenter the live stream. •Any pumps used in areas not cleared of fish shall be screened according to the NMFS screening criteria for 	Project applicant and contractors implementing the project.	Prior to and during any construction activities, as specified	California Department of Fish & Wildlife (CDFW), National Marine Fisheries Service (NMFS) and United States Fish and Wildlife Service (USFWS)
-----------------------	--	---	---	---

Environmental Impact	Mitigation Measure	Responsible for Implementation	Timing of Compliance	Oversight of Implementation
<p>Impact BIO-1.2</p>	<p>waters containing salmonids (NMFS 1997). Once an area has been cleared, no additional screening shall be required.</p> <p>MM BIO-1.2, California Red-legged Frog Survey</p> <p>To avoid take of the CRLF, the following mitigation measures are proposed:</p> <ul style="list-style-type: none"> •Within 24 hours prior to the start of construction, a NMFS- and USFWS-approved biologist shall conduct a preconstruction survey for CRLF within the bounds of the work area. •The NMFS- and USFWS-approved biologist shall have stop work authority for all project activities to protect CRLF and shall be given the authority to communicate with the USFWS if they exercise such authority. •If CRLF are detected during preconstruction surveys, or during the course of work, any work in the vicinity that may threaten CRLF shall stop. The NMFS- and USFWS-approved biologist shall then determine the best course of action. If possible, the CRLF will be monitored and allowed to leave the area of its own volition. However, if the CRLF is unlikely to fully relocate out of the work area on their own in a reasonable timeframe, or if they cannot leave the area without exposure to other risks (e.g. predation); the individual(s) shall be captured and relocated. •Any vegetation that is proposed for removal and could conceal CRLF shall be removed under the supervision of a NMFS- and USFWS-approved biologist. If vegetation is too dense to be adequately surveyed (e.g. tall grasses, or blackberry), the NMFS- and USFWS-approved biologist may request that vegetation is cut to a height of six to 12 inches (and cut vegetation removed) prior to conducting a survey. If no CRLF are found, the vegetation shall be cut to ground level before work with tracked or wheeled equipment is initiated. •Project-related vehicles shall observe a 20-mile per hour speed limit within the work area. All construction activities 	<p>Project applicant and contractors implementing the project.</p>	<p>Prior to and during any construction activities, as specified</p>	<p>CDFW, NMFS and USFWS</p>

Environmental Impact	Mitigation Measure	Responsible for Implementation	Timing of Compliance	Oversight of Implementation
	<p>shall cease one half hour before sunset and shall not begin prior to one half hour after sunrise.</p> <ul style="list-style-type: none"> •Construction activities shall not occur during rain events or within 24 hours of events which have delivered greater than 0.25 inches of rain, until a NMFS- and USFWS- approved biologist resurveys and clears the work site. •Erosion control structures shall not include monofilament netting or similar materials that may entangle CRLF. •Any open holes or trenches shall be covered or have escape ramps installed to prevent CRLF from becoming entrapped. •Any pipes or similar materials required for the project shall be stored in upland areas, and elevated or covered to prevent entrance by CRLF. 			
Impact BIO-1.3	<p>MM BIO-1.3, San Francisco Dusky-footed Woodrat Survey</p> <p>Prior to the initiation of project work within the creek or banks of San Francisquito Creek, a qualified biologist shall conduct a preconstruction survey for dusky-footed woodrat nests. If a dusky-footed woodrat nest is found during the survey, the qualified biologist shall relocate it outside of the work area, out of harm’s way or allow it to move out of the area under its own power.</p>	Project applicant and contractors implementing the project.	Prior to and during any construction activities, as specified	CDFW and City’s PDS Department
Impact BIO-1.4	<p>MM BIO-1.4, Nesting Bird Survey</p> <p>A qualified wildlife biologist shall conduct a nesting bird survey no more than 14 days prior to the start of project construction activities. During this survey, the ornithologist shall inspect all trees and other potential nesting habitats (e.g., trees, shrubs, ruderal grasslands, buildings) in and immediately adjacent to the impact areas for nests) If no active nests are identified during the surveys, no disturbances will occur to birds and work will progress without restriction. If active nests are identified, a no-disturbance buffer around the nest shall be implemented to avoid disturbances to nesting birds. Buffers will be determined by a qualified biologist, and typically range</p>	Project applicant and contractors implementing the project.	Prior to and during any construction activities, as specified	CDFW and City’s PDS Department

Environmental Impact	Mitigation Measure	Responsible for Implementation	Timing of Compliance	Oversight of Implementation
	from 25 feet to 500 feet depending on the species and protection status of that species. Once an active nest is determined to no longer be active, because of young fledging or predation, the buffer around the nest shall be removed and work will progress without restriction.			

CULTURAL RESOURCES

Impact CUL-2.1	MM CUL-2.1, Archaeological Monitoring The property owner or its designee shall hire an Archaeological Monitor to provide spot check monitoring during ground-disturbing activities and to provide on-call support in the event of an unanticipated discovery. The Archaeological Monitor must have a degree in Archaeology or a related field and must have at least one year of demonstrated field experience. The Archaeological Monitor shall work under the supervision of a Professional Archaeologist meeting the minimum requirements of the Secretary of the Interior’s Standards for Prehistoric and Historic Archaeology. The qualifications of the Archaeological Monitor and the Professional Archaeologist shall be provided to the City Planning & Development Services (PDS) Department for review and approval prior to construction. If, in the course of construction, a resource is uncovered that is determined to be Native American in nature, the appropriate tribe shall be contacted and offered the opportunity to provide monitoring of ground-disturbing activities. If Native American monitoring is requested, the Native American Monitor may determine at any point during the course of construction that ground-disturbing activities are not anticipated to result in impacts to a tribal cultural resource and that Native American Monitoring may cease. Documentation of this determination shall be provided to the City PDS Department in writing.	Project applicant and contractors implementing the project.	Prior to and during any construction activities, as specified	City’s PDS Department
	MM CUL-2.2, Resource Discovery If prehistoric or historic resources are encountered during excavation and/or grading of the site, all activity within a	Project applicant and contractors implementing the	During construction, in the event of cultural resource	City’s PDS Department and United States Army Corps of

Environmental Impact	Mitigation Measure	Responsible for Implementation	Timing of Compliance	Oversight of Implementation
	<p>50-foot radius of the find shall be stopped, the City of Palo Alto Planning & Development Services Department and the United States Army Corps of Engineers (USACE) shall be notified, and a qualified archaeologist shall examine the find. The archaeologist shall 1) evaluate the find(s) to determine if they meet the definition of a historical or archaeological resource; and 2) make appropriate recommendations regarding the disposition of such finds prior to issuance of building permits. Recommendations could include collection, recordation, and analysis of any significant cultural materials. A report of findings documenting any data recovery shall be submitted to the Planning & Development Services Department and the Northwest Information Center (if applicable). Project personnel shall not collect or move any cultural materials. The project applicant shall implement the recommendations of the qualified archaeologist.</p>	project.	discovery	Engineers (USACE)
	<p>MM CUL-2.3, Worker Training</p>	Project applicant	Prior to	City's PDS
	<p>Prior to construction, the archaeological monitor shall provide a worker environmental awareness training to all site personnel. The training shall discuss the appearance of resources that may be encountered during construction and the procedures and notification process in the event of a discovery.</p>	and contractors	construction	Department
		implementing the		
		project.		
Impact CUL-3.1	<p>MM CUL-3.1, Human Remains</p>	Project applicant	During	City's PDS
	<p>If any human remains are found during any field investigations, grading, or other construction activities, all provisions of California Health and Safety Code Sections 7054 and 7050.5 and Public Resources Code Sections 5097.9 through 5097.99, as amended per Assembly Bill 2641, shall be followed. If human remains are discovered during construction, there shall be no further excavation or disturbance of the site or any nearby area reasonably suspected to overlie adjacent remains. The project applicant shall immediately notify the City of Palo Alto Planning & Development Services Department and a qualified archaeologist, who shall then notify the Santa</p>	and contractors	construction, in	Department,
		implementing the	the event of	Santa Clara
		project.	human remains	County Coroner,
			discovery	and Native
				American Heritage
				Commission (if
				applicable)

Environmental Impact	Mitigation Measure	Responsible for Implementation	Timing of Compliance	Oversight of Implementation
	<p>Clara County Coroner. The Coroner will make a determination as to whether the remains are Native American. If the remains are believed to be Native American, the Coroner will contact the (Native American Heritage Commission) NAHC within 24 hours. The NAHC will then designate a Most Likely Descendant (MLD). The MLD will inspect the remains and make a recommendation on the treatment of the remains and associated artifacts. If one of the following conditions occurs, the landowner or his authorized representative shall work with the Coroner to reinter the Native American human remains and associated grave goods with appropriate dignity in a location not subject to further subsurface disturbance:</p> <ul style="list-style-type: none">•The NAHC is unable to identify an MLD or the MLD failed to make a recommendation within 48 hours after being given access to the site;•The MLD identified fails to make a recommendation; or•The landowner or his authorized representative rejects the recommendation of the MLD, and the mediation by the NAHC fails to provide measures acceptable to the landowner.			

Environmental Impact	Mitigation Measure	Responsible for Implementation	Timing of Compliance	Oversight of Implementation
GEOLOGY/SOILS				
Impact GEO-6.1	<p>MM GEO-6.1, Worker Training</p> <p>A qualified paleontologist will develop a Worker’s Environmental Awareness Program (WEAP) to train the construction crew on the legal requirements for preserving fossil resources as well as procedures to follow in the event of a fossil discovery. This training program will be given to the crew before ground-disturbing work commences and will include handouts to be given to new workers as needed.</p>	Project applicant and contractors implementing the project.	Prior to construction	City’s PDS Department
	<p>MM GEO-6.2, Unique Paleontological and/or Geologic Features and Reporting</p> <p>Should a unique paleontological resource or site or unique geological feature be identified at the project site during any phase of construction, all ground disturbing activities within 25 feet shall cease and the City’s Planning Manager notified immediately. A qualified paleontologist shall evaluate the find and prescribe mitigation measures to reduce impacts to a less than significant level. Upon completion of the paleontological assessment, a report shall be submitted to the City and, if paleontological materials are recovered, a paleontological repository such as the University of California Museum of Paleontology shall also be submitted to the City.</p>	Project applicant and contractors implementing the project.	During construction, in event of paleontological or unique geological resource discovery	City’s Planning Manager
HYDROLOGY/WATER QUALITY				
Impact HYD-3	<p>MM HYD-3.1, Crib Wall Monitoring</p> <p>The crib wall shall be monitored for a minimum of five years during and immediately after each rainy season post-construction and shall include a survey of three cross sections. Monitoring documentation shall include, at minimum, a description the topographic elevation, cover material, and conditions (i.e., vegetation, sediment) for each cross section and shall note and photo-document any changes. If the trajectory of the channel suggests that the left (north) bank of the creek is experiencing morphologic</p>	Project applicant and contractors implementing the project.	Minimum of five years during and after each rainy season post-construction.	City’s PDS Department

Environmental Impact	Mitigation Measure	Responsible for Implementation	Timing of Compliance	Oversight of Implementation
	<p>changes that threaten to erode the upper terrace outside of the active channel, the applicant or their designee shall prepare a geomorphic assessment to determine the cause of the issue and identify appropriate measures to address the off-site erosion. Appropriate measures include, but are not limited to, activities within Palo Alto’s jurisdiction such as the removal of accumulated sediment from the active channel, removal of debris accumulated along or near the crib wall, thinning or trimming of vegetation, and/or installation of willow poles or other bioengineering measures.</p>			

1.0 INTRODUCTION AND PURPOSE

This application for a Minor Architectural Review has been prepared for the City of Palo Alto (the City), on behalf of the Children’s Health Council (CHC), in order to ensure compliance with local and state codes for approval of proposed creek bank stabilization work in San Francisquito Creek, adjacent to the CHC property. This permit application package describes the environmental setting, existing and proposed uses of the project site, purpose of the project, and project scope of work for the CHC San Francisquito Creek Bank Stabilization Project - Phase II (proposed project).

The CHC provides specialized education and clinical services to children and teens with autism, ADHD, anxiety, depression, and other learning differences. The banks of San Francisquito Creek at the margins of the Stanford property leased to CHC are at high risk for erosion, which accelerated during the 2016–2017 rainy season, resulting in the loss of approximately 50 horizontal feet of the creek bank and 7,500 square feet of the outdoor learning area (Figure 1). Phase I of the stabilization work, completed in February 2019, included emergency installation of a shear pin wall outside of the top of bank of San Francisquito Creek to stabilize the property behind the eroding bank and prevent imminent dangers to the property and human safety. The purpose of Phase II is to complete in-channel creek bank stabilization that would minimize risk of future erosion, exposure of the shear pin wall, and continued bank failure.



Figure 1. Creek Bank Erosion. Image (11/02/2016) shows creek bank loss during the 2016-2017 winter storms.

2.0 PROJECT INFORMATION

2.1 Project Title

Children's Health Council San Francisquito Creek Bank Stabilization Project – Phase II

2.2 Project Location

The project site is located at 650 Clark Way, in the City of Palo Alto, situated in the far northwestern corner of Santa Clara County, California, identified as Assessor's Parcel Number (APN) 142-02-015 (Figure 2). The project site is bordered by San Francisquito Creek and is surrounded primarily by residential homes, retail, and institutional facilities (Figures 3 and 4).

Regional Setting

The CHC property in Palo Alto is being leased from Stanford University. It lies in northwestern Santa Clara County, approximately 55 feet southeast of the San Mateo County border. The project site is situated in a mainly urban and suburban landscape with Palo Alto to the northeast, Stanford University lands to the southeast, West Menlo Park to the southwest, and Menlo Park to the northwest.

The project site is bordered by San Francisquito Creek to the west and north. As shown in Figure 1, State Highway 82 is 0.6 mile northeast, Highway 101 is 2.25 miles northeast, and US Interstate 280 is 2.25 miles southwest of the project site.

Local Setting

The project site is located near Stanford University within a predominantly suburban setting. The immediate surrounding areas consist of high and low-density residential, commercial, and academic institutional land uses. There are single-family homes located to the north across San Francisquito Creek, select businesses to the northeast, the CHC playground and school to the east, and open space surrounded by apartment buildings to the south. The larger vicinity also contains retail and institutional facilities. An image showing the relationship of the proposed project site to the neighborhood and to surrounding land uses can be seen in Figure 3.

Site Setting

The proposed work area is at the northwestern portion of the Children's Health Council campus located at 650 Clark Way in Palo Alto. The CHC property line is defined by the historic centerline of San Francisquito Creek. The proposed work would take place on CHC property within San Francisquito Creek, below the top of bank. Channel banks in this area are approximately 30 feet high. A gravel access road, where the Phase I shear pin wall was installed, forms the northeastern boundary of the site, followed by the CHC playground, containing landscaped grass and shrubs and built children's play equipment. In the area of proposed work, San Francisquito Creek is bordered by single-family residences under West Menlo Park jurisdiction to the west and south. The property is designated as Major Institution/Special Facility according to the City of Palo Alto Comprehensive Plan, which is defined as "institutional...lands that are either publicly owned or operated as non-profit organizations." The Children's Health Council operates consistent with this capacity under a lease from Stanford University.

There are no structures, parking, or other uses at the location of the proposed work, and none are proposed as part of the project. The vicinity of the project site is sparsely vegetated by non-native grasses and herbs, as well as coast live oaks, bay laurels, and buckeyes. The portion of San Francisquito Creek that runs through the project site is designated as critical habitat for

Central California Coast Distinct Population Segment steelhead (steelhead: *Oncorhynchus mykiss*), a federally listed endangered species, so any in-channel work would require special provisions to minimize potential impacts to the species. California red-legged frog (CRLF: *Rana draytonii*), a federally listed threatened species, has been documented in San Francisquito Creek upstream of the project site; therefore, any vegetation removal or in-channel work would also require special provisions to minimize impacts to this species. Photographs of the existing parcel are included in Figure 4.

2.3 General Plan Designation and Zoning District

- Comprehensive Plan Designation: Major Institution/Special Facility
- Zoning Designation: Public Facilities District (PF)

The project site, as described by the City of Palo Alto Comprehensive Plan, is designated as Major Institution/Special Facility, and the Palo Alto Municipal Code has zoned the parcel Public Facilities District (PF).

This page left intentionally blank.

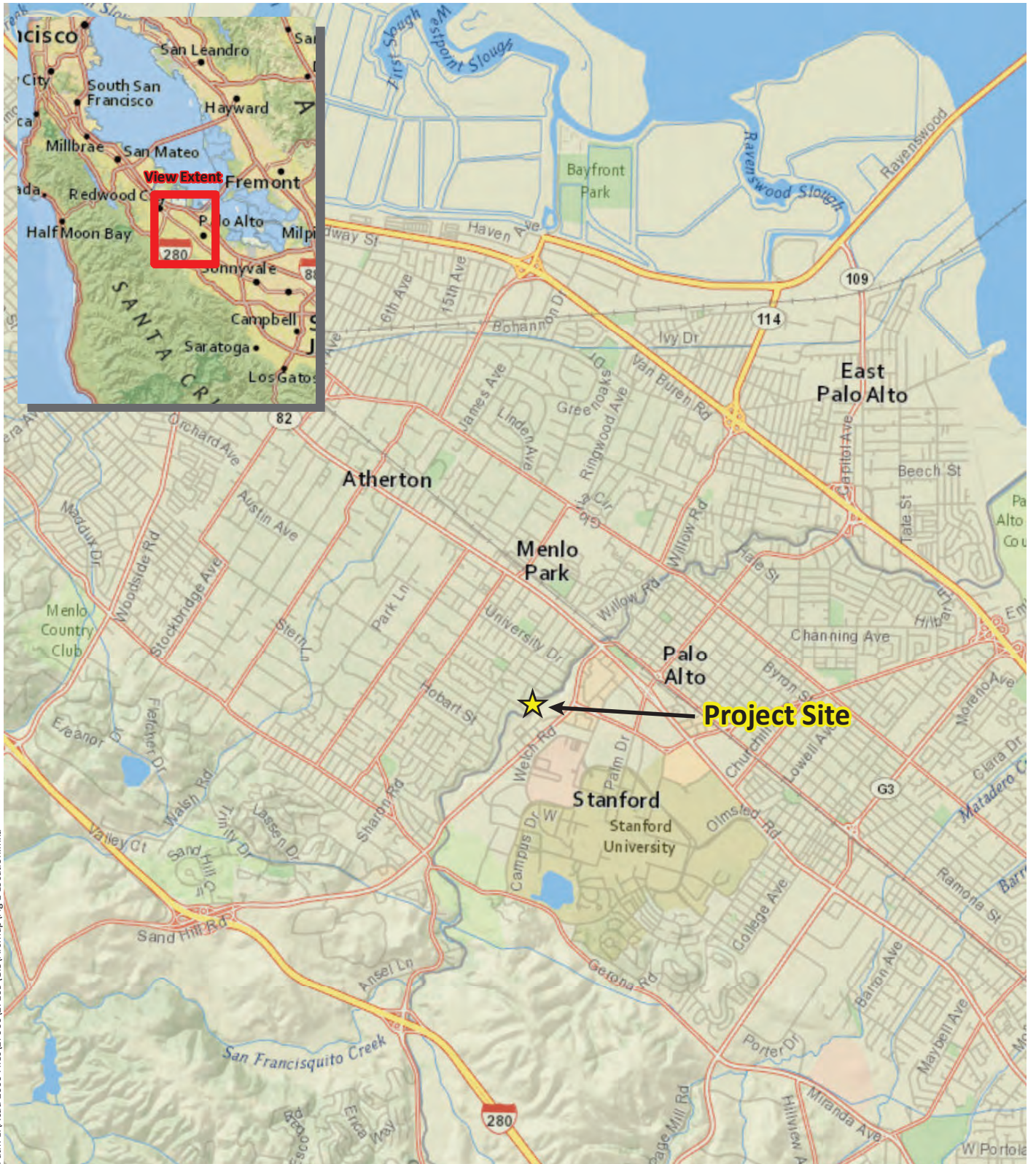

Path: L:\Acad 2000 Files\27000\27109\GIS\ArcMap\Fig 1 Location.mxd

Sources: National Geographic, WRA | Prepared By: czumwalt, 2/16/2018

Figure 2. Project Site Location Map

Children's Health Council
San Francisquito Creek Bank Stabilization Project - Phase II
City of Palo Alto, California

0 0.5 1 Miles



This page left intentionally blank.

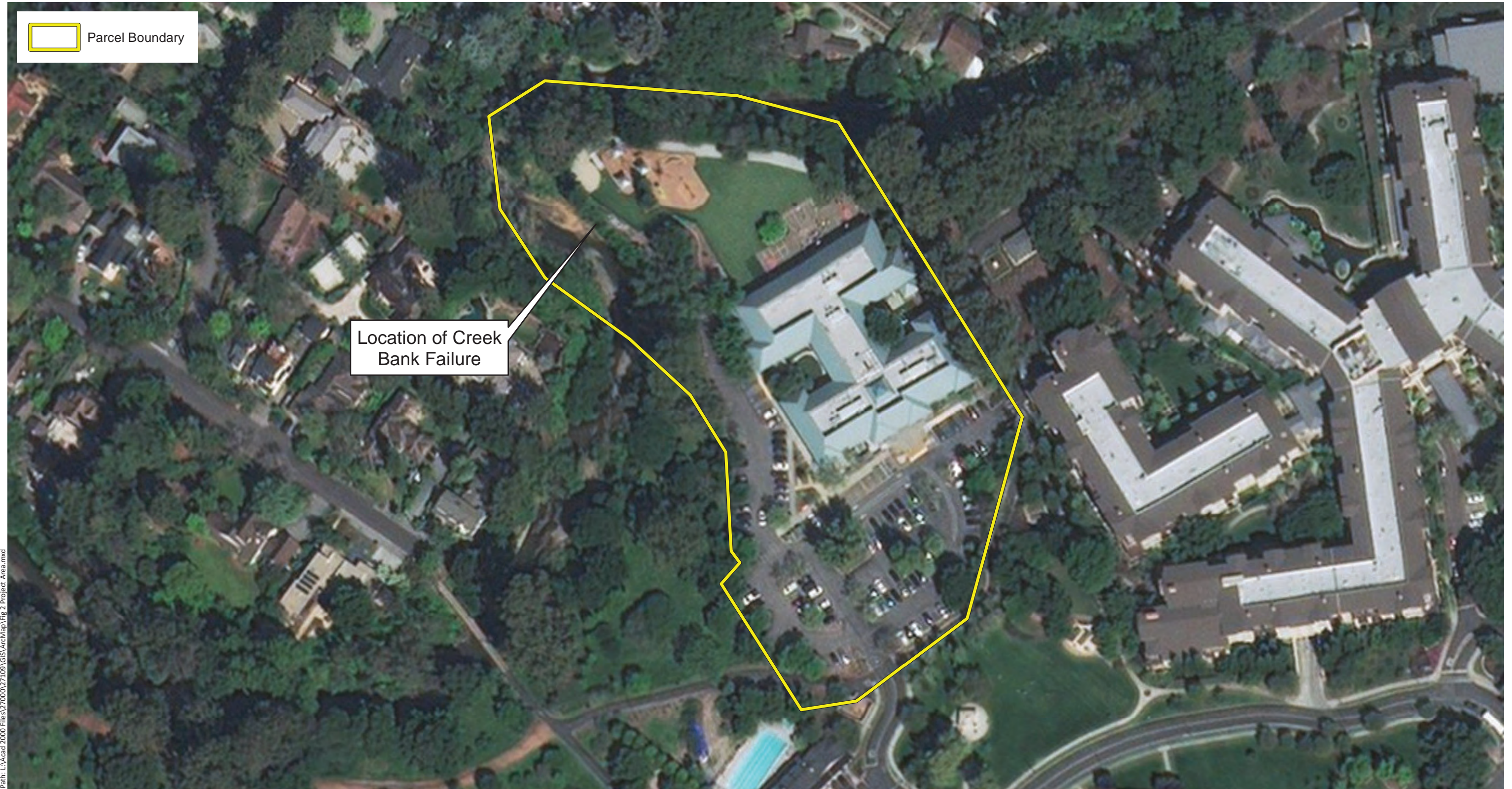

Path: L:\Acad\2000 Files\27000\27109\GIS\ArcMap\Fig. 2 Project Area.mxd

Sources: Esri Streaming - DigitalGlobe 2016 | Prepared By: czumwalt, 3/1/2018

Figure 3. Aerial of the Project Site and Surrounding Lands

Children's Health Council
San Francisquito Creek Bank Stabilization Project - Phase II
City of Palo Alto, California

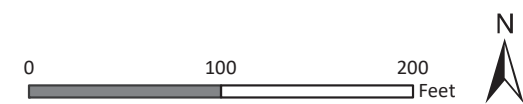

This page left intentionally blank.



View 1. View of the creek bank failure at the project site, looking across San Francisco Creek.



View 2. View of the creek bank failure and San Francisco Creek, looking north from within the creek bed.



View 3. Northwestern view of the creek bank failure and San Francisco Creek, on top of the creek bank.



View 4. Southeastern view of the creek bank failure and San Francisco Creek, on top of the creek bank.

Figure 4. Views of the Project Site

Children's Health Council San Francisco Creek Bank Stabilization Project - Phase II
 City of Palo Alto, California

This page left intentionally blank.

3.0 PROJECT DESCRIPTION

3.1 Project Description

The banks of San Francisquito Creek at the margins of the Stanford property, leased to CHC and adjacent to the school's outdoor learning area, are at high risk for erosion and are identified as a high priority for stabilization in the San Francisquito Creek Joint Powers Authority (JPA) Bank Stabilization and Revegetation Master Plan. Recent active erosion of the channel banks on the CHC property accelerated during the 2016 – 2017 rainy season, resulting in the loss of approximately 20 horizontal feet of the creek bank and 7,500 square feet of CHC's outdoor learning area. The channel banks in the area of accelerated erosion are approximately 30 feet high, and intact soils behind the bank failure are cracking and near failure.

Due to the nature, location, and time-sensitivity of the creek bank failure, an emergency project was approved by the City of Palo Alto on September 24, 2018 (Phase I of the proposed project). The purpose of Phase I was to stabilize the eastern bank of San Francisquito Creek to prevent further loss of outdoor learning areas used by CHC's students and minimize hazards to public safety due to imminent continued bank loss. Phase I of the project, completed in February 2019, included emergency installation of 19 concrete "shear pins" and steel tie-backs, set back from the creek bank by about 6 feet and extending 20 feet vertically below the existing creek bed. The shear pin wall is meant to stabilize the property behind the eroding bank and prevent imminent dangers to the property and human safety. The shear pins are a line-of-last-defense against bank retreat and loss of property into the creek, but do not protect the existing character of San Francisquito Creek, which supports significant ecological resources.

In approving the Phase I emergency project, the City of Palo Alto stipulated a number of Conditions of Approval. The thirteenth condition states, "Following approval of this project, the property owner or its designee shall apply for permits with the City of Palo Alto and other applicable agencies to complete in-channel creek bank stabilization." The condition goes on to say that, "the purpose of this secondary project would be to minimize risk of future exposure to the shear pin wall, maintain or improve sediment transport by minimizing continued erosion along the base of the wall adjacent the subject property, and maintain or otherwise improve stream function." The proposed project is a direct response to this Condition of Approval from the City.

Project Design

Background

The Phase II project design was developed through a process of site assessment, data gathering, 1-D hydraulic modeling, 2-D hydrodynamic modeling, review of local stream maintenance requirements from Santa Clara Valley Water District, and CAD-based design.

WRA is proposing a living log crib wall with rock toe protection to stabilize the proposed project site. Crib walls have a natural aesthetic, provide immediate protection, and encourage the establishment of woody plant species. This method has been found to be highly effective on the outside bend of streams where there are high velocities and where a wall is needed to stabilize the toe and reduce slope steepness. Crib walls can have a slope of up to 0.25:1 (horizontal to vertical) and can withstand flows of up to 12 feet per second. No other "soft" bank stabilization measures meet those criteria. The rock toe protection would be required to prevent the channel from undercutting the crib wall.

A site plan of the project design and its orientation relative to San Francisquito Creek, the property boundary, and to the Phase I shear pins is presented in Attachment 4 (30% Design Plans) of this submittal.

Design Constraints

Primary site constraints that influenced the design are as follows:

- No excavation of the existing bank is allowed by the property owner, Stanford University, due to the risk of disturbing cultural resources.
- San Francisquito Creek is designated as critical habitat for Central California Coast Distinct Population Segment steelhead in the segments that adjoin the property, therefore, any work proposed within the channel will require special provisions to minimize potential impacts to the species and its critical habitat.
- California red-legged frog is documented to occur in San Francisquito Creek upstream of the property; therefore, any vegetation removal or work within the channel will require special provisions to minimize potential impacts to the species.
- The project may not result in increased water surface elevations relative to the FEMA 100-year flood evaluation.
- The project may not increase risk of bank failure to neighboring properties.
- The property boundary of the parcel upon which CHC is located is delineated by the historic centerline of the creek channel, therefore any work that would potentially impact adjacent properties would require obtaining temporary or permanent easements on the adjacent properties.
- The Stanford-owned property located immediately to the southeast is subject to a conservation easement that does not allow construction of any kind.
- The size of the bank failure is significant and requires significant stabilization efforts, but its proximity to the outdoor learning area requires significant provisions for public safety.

Site Preparation

Prior to installing the crib wall and rock toe, site preparation activities would need to take place. This would include vegetation removal, construction of a temporary access route, fish salvage (if necessary), and installing a water diversion structure to dewater the work area (if necessary). A temporary access pathway would be constructed to allow construction equipment and construction personnel ingress and egress from within the work area, which is discussed further below under Site Access, Circulation, and Parking.

Because the work does not span the entire creek channel, water can be diverted around the work area without the need for bypass pumps; rather, the area would be dewatered by building a sand bag diversion to isolate the work area from flow if necessary. Water accumulating within the work area would also be dewatered following fish salvaging activities.

Crib Wall

The crib wall design calls for stacked layers of 1.5-foot-diameter logs and rootwads, alternating in direction like a log cabin, but rather than building a vertical wall, the structure would be at a 1:1 slope. The first level of the crib wall would be tie-back logs, braced to absorb the impact of the streamflow. The first level of the crib wall also include 13 rootwads, or large diameter coarse woody debris, spaced approximately ten feet apart along the natural pool of the creek, which provide interstitial spaces for fish habitat. They are strategically located by existing pools in the creek to help reduce water velocities during high flow events. The second layer of the crib wall consists of two rows of logs parallel to the streamflow connecting the first layer of tie-back logs. Each log would be pinned to the logs below using steel bolts, nuts, and washers to provide

redundancy in structural loading. Helical anchors would also be driven into the soil and connected to the crib wall to prevent the overall structure from moving laterally.

The third layer of crib wall is similar to the first layer, using tie-back logs, and the fourth layer would connect to the tie-back logs underneath, in the same manner that connected the second layer to the first, and so on. Live willow cuttings would be inserted in the voids between logs to provide riparian habitat, reduce water velocities along the crib wall, and grow complex root structures around the crib wall that provide additional stability. Willow cuttings would be long enough to have their cut end inserted into the native soil behind the crib wall, at least three feet into the structure. Logs would be placed until the desired height of bank protection is achieved, approximately five to ten feet. The bank above the crib wall would be graded at a 2:1 slope from the top of the crib wall to the existing bank.

Following completion of final grading and work on the lower and upper channel bank, riparian areas within the limit of grading would be replanted with native woody and herbaceous vegetation, in order to avoid and minimize overall impacts to riparian vegetation. Replanting includes three distinct native riparian planting schedules. The lowest portion of the crib wall would be planted with arroyo willow (*Salix lasiolepis*) and sandbar willow (*Salix exigua*) stakes placed within the lower crib wall cavities. The remaining slopes above would be planted with native shrub and tree species and hydroseeded with a native riparian seed mix. Native riparian plantings would be installed and established to provide additional habitat value and soil stability in this area.

The design life of the project is 50 years or more, assuming the plantings thrive. The crib wall would require minimal maintenance other than irrigation and maintenance if damage or debris collection occurs due to large storm events. The gaps between the logs of the crib wall filled with willows and other vegetation, as well as the rootwads themselves, would be accessible to rearing salmonids and would provide high flow refugia, cover, and forage habitat. The improvements, including the success of riparian plantings, would be monitored for ten years, beginning after one full rainy season post completion of the project to ensure success of the stabilization and replanting activities.

Rock Toe Protection

The design calls for toe protection at the base of the slope, under the first row of the crib wall, using large boulders and cobbles. These boulders would be approximately two to three feet in diameter.

Avoidance and Minimization Measures

The project will result in impacts to stream and riparian habitat, as well as having the potential to impact steelhead individuals and critical habitat as well as CRLF individuals. The following avoidance and minimization measures will be implemented to reduce impacts to these species to less than significant.

Stream and Riparian Habitat

The project will result in impacts to stream and riparian habitat. Implementation of the measures below will result in the minimization of impacts to the greatest extent possible.

- Erosion control measures will be utilized throughout all phases of operation where sediment runoff from exposed slopes threatens to enter all waters of the U.S. At no

- time will silt laden runoff be allowed to enter the channel or directed to where it may enter the stream. Erosion control structures will be monitored for effectiveness and will be repaired or replaced as needed. Appropriate erosion control measures will be installed around any stockpiles of soil or other materials which could be mobilized by rainfall or runoff.
- Stockpiles of soil or other materials that can be blown by wind will be covered when not in active use. All trucks hauling soil, sand, and other loose materials will be covered.
 - No construction debris such as rubbish, creosote-treated wood, soil, silt, sand, cement, concrete or washings thereof, or other construction-related materials or wastes will be allowed to enter into or be placed where they may be washed into any aquatic features. All such debris and waste will be picked-up regularly and will be disposed of at an appropriate facility.
 - No fueling, or maintenance of vehicles or equipment will take place within any areas where an accidental discharge to San Francisquito Creek may occur. Refueling or maintenance of stationary equipment within the channel (top of bank to top of bank) shall only occur when secondary containment sufficient to eliminate escape of all potential fluids is in place. If any spills do occur, they shall be cleaned immediately.
 - Any equipment or vehicles operated adjacent to aquatic features will be checked and maintained daily to prevent leaks of materials that could be deleterious to wildlife or habitat
 - Staging and storage areas for equipment, materials, fuels, lubricants and solvents, will be located outside of the stream channel banks
 - All equipment, including excavators, trucks, hand tools, etc., that may have come in contact with invasive plants or the seeds of invasive plants, will be cleaned before arriving on the site and will also be cleaned before being deployed at any sites after completion of the Project.
 - Prior to the start of construction, the contractor shall prepare a Spill Prevention and Cleanup Plan. This plan shall include procedures to be followed in the event of spills as well as information regarding the disposal of any spilled materials.
 - Spill kits will be present on-site and available at all times.
 - Construction disturbance or removal of vegetation will be restricted to the minimum footprint necessary to complete the work. The work area will be delineated where necessary with high visibility markers to minimize impacts to habitat beyond the work limit. Project activities will avoid impacts to riparian vegetation to the greatest extent possible.
 - Stationary equipment such as motors, pumps, and generators, located adjacent to aquatic features will be positioned over drip pans. Stationary heavy equipment will have suitable containment to handle a spill or leak. All activities performed near aquatic features will have absorbent materials designated for spill containment and cleanup activities on-site for use in an accidental spill.
 - An environmental awareness training for all crews working on the site shall include education on sensitive resources such as protected wildlife with the potential to occur

- within the area (identification, regulatory status, natural history), water quality and environmental protection measures.
- A litter control program will be instituted. All workers will ensure their food scraps, paper wrappers, food containers, cans, bottles, and other trash are deposited in covered or closed trash containers. The trash containers will be removed from the project site at the end of each working day.
 - All temporary flagging and/or barriers will be removed from the Project Area upon completion of project activities.

Areas of ground disturbance will be revegetated using a native erosion control seed mix, with species composition appropriate for the habitat type, or will be covered with rock, wood chips, or other suitable erosion control materials as appropriate (applicable to non-sensitive habitats only). A Habitat Mitigation and Monitoring Plan (HMMP) will be developed for revegetated riparian areas. Monitoring of revegetated riparian areas will occur for ten years, beginning after one full rainy season following implementation of the HMMP.

Special-Status Fish

Flow in San Francisquito Creek is anticipated to be low, or absent in the dry season when the Project is proposed to occur. If the Project Area is naturally dry, as is typical for the proposed work window, then no dewatering, or additional avoidance measures for steelhead are required beyond the general measures listed above for Stream and Riparian Habitat.

If water is present in San Francisquito Creek when work is scheduled to begin, dewatering will be required, and additional measures are warranted. Any general measures stated above for Stream and Riparian Habitat will be followed throughout the Project. For the protection of steelhead and their critical habitat, the Project proponents will conduct consultation with the National Marine Fisheries Service (NMFS) and any requirements or measures resulting from that process will be implemented. In addition, the following measures will be applied if water is present and dewatering is required to minimize impacts to steelhead to less than significant levels.

- A Fish Rescue and Relocation Plan will be drafted and submitted to the NMFS outlining the methods to be used (e.g., electrofishing, seining, etc.) as well as decontamination procedures, and any reporting procedures that shall be followed.
- Any electrofishing will be conducted according to NMFS Guidelines for Electrofishing Waters Containing Salmonids Listed Under the Endangered Species Act (2000).¹
- Any work within aquatic habitats shall be completed during the dry season, between May 1 and October 15.
- The qualifications of the biologist who will lead the fish rescue will be submitted to the NMFS for review and written approval at least thirty (30) calendar days prior to the date dewatering is scheduled. The lead biologist will be assisted at least one other individual when conducting a rescue and relocation.

¹ [NMFS] National Marine Fisheries Service. 2000. Guidelines for Electrofishing Waters Containing Salmonids Listed under the Endangered Species Act. NMFS, 5 pp.

- If pumps are used to bypass flow, or to assist with initial dewatering within the Project Area, they will be screened in accordance with NMFS screening criteria for waters containing salmonids². Screening requirements will not be applied to pumps used to address refuge groundwater or other seepage inside the Project Area once the fish rescue is completed.
- Any sediment-laden water will be filtered or discharged into a suitable location where settling may occur before water reenters the channel.
- When construction is complete, any infrastructure temporarily installed to bypass flows will be removed to allow flow to resume naturally.
- Prior to and after use within the Project Area any fisheries equipment will be sterilized to prevent the introduction or spread of invasive species or disease.

California Red-legged Frog

- The qualifications of any biologists who will perform surveys for or who will relocate CRLF (Approved Biologist(s)) will be submitted to the USFWS for review and written approval at least thirty (30) calendar days prior to initiation of the Project. An Approved Biologist will be onsite during all activities that may result in take of the California red-legged frog.
- Within 48 hours prior to the start of construction, an Approved Biologist will conduct a preconstruction survey for CRLF in and adjacent to the Project Area.
- The Approved Biologist will have stop work authority for all Project activities to protect CRLF.
- If CRLF are detected during preconstruction surveys, or during the course of work, any work in the vicinity that may threaten CRLF will stop. The Approved Biologist will then determine the best course of action based on the situation at hand. If possible, the CRLF will be monitored and allowed to leave the area of its own volition. However, if the CRLF is unlikely to fully relocate out of the Project Area on their own in a reasonable timeframe, or if they cannot leave the area without exposure to other risks (e.g. predation); the individual(s) will be captured and relocated in accordance with the process outlined below.
 - Before beginning a relocation, the Approved Biologist will assure any equipment used for the relocation has been properly cleaned and decontaminated. If using their hands to capture CRLF, they will either don sterile gloves, or assure their hands are free from toxic substances such as insect repellent, sunscreen or other chemicals.
 - Using a dip net, or wetted hands, the Approved Biologist will catch the CRLF and place it into a clean container (e.g. bucket with a lid).
 - If multiple frogs of similar age class are captured, they may be put into the same container. However, frogs of varying age class will be segregated into separate containers to avoid predation.
 - Once all CRLF have been captured, the Approved Biologist will relocate the animals upstream or downstream to the nearest suitable habitat. Release locations will be at least 200-feet from the Project Area.
 - After relocation, all equipment will be sterilized according to the industry standards to prevent the spread of disease.
 - The Approved Biologist will contact the USFWS within 24 hours following any relocation to report the relocation of CRLF.

² [NMFS] National Marine Fisheries Service. 1997. Fish screening criteria for anadromous salmonids. NMFS, Southwest Region, Santa Rosa, California.

- Prior to the commencement of work with wheeled or tracked equipment in undisturbed areas, vegetation that could conceal CRLF shall be removed under the supervision of an Approved Biologist after they have surveyed the area and determined it to be free of CRLF. If vegetation is too dense to be adequately surveyed (e.g. tall grasses, or blackberry), the Approved Biologist may request that vegetation is cut to a height of 6-12 inches (and cut vegetation removed) prior to conducting a survey. If no CRLF are found, the vegetation shall be cut to ground level before work with tracked or wheeled equipment is initiated.
- Once all vegetation has been removed that may conceal CRLF, the Project Area shall be surveyed each day prior to commencement of work by a qualified individual who has been trained by the Approved Biologist. The daily preconstruction survey will be conducted to ensure that no CRLF are present in the Project Area. If the qualified individual observes a CRLF, work in the vicinity will halt and the Approved Biologist will be contacted. The qualified individual will monitor the CRLF until the Approved Biologist arrives, at which point, the animal will be relocated, if it has not already done so.
- Project-related vehicles will observe a 20-mile per hour speed limit within the Project Area. All construction activities will cease one half hour before sunset and shall not begin prior to one half hour after sunrise.
- Construction activities shall not occur during rain events or within 24 hours of events projected to deliver >0.25 inches of rain or within 24 hours after rain events exceeding 0.25 inches in measureable precipitation, as CRLF are most likely to disperse during periods of precipitation. No work shall occur after 0.5 inches of rain has occurred after November 1 in the year work is occurring.
- Erosion control structures shall not include monofilament netting.
- Any open holes or trenches shall be covered or have escape ramps no steeper than 45 degrees installed at the end of each working day to prevent CRLF from becoming entrapped.

Site Access, Circulation, Parking, and Staging

Access to the project site is proposed via Sand Hill Way (to the east of the CHC property) and Clark Way (leading up to the project site). Parking is available associated with the CHC school building, approximately 150 feet southeast of the project site. An access route would be constructed, using temporary fill to be removed upon completion of the project. The access route would connect the CHC parking lot and the project site and would require vegetation trimming and the removal of understory vegetation, shrubs, and six trees, including two protected trees (see Tree Removal below for more details).

A designated staging area will be located within the boundaries of the CHC leasehold along the terminus of Clark Way, north of the CHC school parking lot. All material excavated out from the stream bank will be stockpiled above the TOB in the designated staging area or hauled off-site. Based on the composition of the excavated material, it will either be hauled off-site and disposed of at a proper facility, or it will be sorted and reused as alluvium backfill within the crib wall.

Grading

The project site measures approximately 300 feet long by 50 feet wide. The proposed project would require approximately 1,450 cubic yards (cy) of soil to be excavated by heavy-duty drilling equipment, consisting mostly of native sediment with some amounts of eroded brick and artificial fill. All artificial debris removed would be off-hauled to an appropriate disposal site, as it is not an appropriate material for backfill within the perennial stream system. Excavated native sediment would be removed from the work area and evaluated for reuse. If reuse is not appropriate, the native material would be off-hauled as well to an appropriate disposal site.

Once the east side of the San Francisquito Creek channel is excavated, a new lower channel bank would be rebuilt with the bioengineered crib wall. Work includes grading, placement of boulder and cobble fill, placement of rootwads and crib logs, placement of engineered fill, and native seeding and planting within the riparian area. Approximately 2,330 cy of clean boulder, cobble, and engineered fill material would be imported to serve as the foundation of the crib wall. An additional 170 cubic yards of woody debris fill would be imported, consisting of rootwads and crib logs. All import material would be transported and stored in a suitable, legal fashion.

Tree Removal

A Tree Survey was completed on February 6, 2018 and November 1, 2019 in accordance with the City of Palo Alto's Tree Protection Manual. Twenty-six trees were identified within the project site and immediate vicinity, including four trees large enough and of qualifying species to be considered protected per the City's Tree Ordinance. Two protected trees (tree #742 and #996 in Attachment 4 to the Development Application) are proposed for removal as part of the project. Several non-protected trees are proposed for removal, including two non-protected California buckeyes (tree #746 and #991 in Attachment 4); one small shrubby red willow (tree # 987); and one 4-inch DBH coast live oak (tree #997), which is growing along the eroding creek bank. No other vegetation removal is proposed.

The first protected tree (tree #742) is a 14.1-inch diameter at breast height (DBH) coast live oak tree that is severely undermined by creek bank erosion, displaying broken and exposed roots including the taproot and significant structural roots. The tree is on the precipice of the rapidly eroding San Francisquito Creek bank, and soil cracking was observed near the tree, further indicating instability and increasing the likelihood of failure. The second protected tree (tree #996) is a 12.6-inch DBH coast live oak tree located at the toe of slope at the bottom of the eroding creek bank along the downstream limit of the proposed crib wall. A tree removal permit would be obtained for the removal of the protected coast live oak trees. Both trees are at severe risk of failure, and as outlined in Section 3.10 of the City's Technical Tree Manual, "When Tree Replacement is Required", tree replacement is not required for tree removals that are authorized by the City because they are "dead, dangerous, or a nuisance." Therefore, tree replacement is not proposed.

Drainage and Utilities

The proposed project would not affect existing utility poles or other utility infrastructure. It would not be necessary to install new drainage or utility infrastructure for this work.

Lighting

Work on the project site would take place during daylight hours only. There is no existing lighting infrastructure at the project site, nor would lighting be installed.

Construction

The construction phase of the stabilization work would require two to three months (8-12 weeks) to complete, taking place in a single dry season (summer 2020). Construction work would occur between 8 AM and 6 PM Monday through Friday and between 9 AM and 6 PM on Saturdays, per the City of Palo Alto's permitted construction hours and noise limits.

Construction equipment would include two medium-size excavators, an off-road hauler, a dump truck, a front-end loader with a screen, dewatering equipment (i.e., pumps, generators, piping), trailers, and assorted power or hand tools. Materials (i.e., logs, boulders, etc.) would be stockpiled

in the CHC parking area, above the top of bank and outside the limit of grading, and would be shuttled to the project site with a loader or rubber track off-road dump truck.

3.3 Project–Related Approvals, Agreements, and Permits

The information contained in this permitting application will be used by the City of Palo Alto for necessary project approvals. These actions include, but may not be limited to, the following approvals by the agencies indicated:

U.S. Army Corps of Engineers (Corps)

- Clean Water Act Section 404

National Marine Fisheries Service (NMFS)

- Federal Endangered Species Act Section 7 Biological Assessment

Regional Water Quality Control Board (RWQCB)

- Clean Water Act Section 401 Water Quality Certification

California Department of Fish and Wildlife (CDFW)

- Section 1602 Streambed Alteration Agreement

City of Palo Alto

- Minor Architectural Review
- Grading Permit
- Building Permit

Santa Clara Valley Water District

- Encroachment permit

Attachment E

Project Plans and Initial Study/Mitigated Negative Declaration

Hardcopies of project plans and the Initial Study are provided to Board members. These plans and environmental documents are available to the public online.

Directions to review Project plans online:

1. Go to: bit.ly/PAPendingprojects
2. Scroll down to find "650 Clark Way" and click the address link
3. On this project specific webpage you will find a link to the project plans and other important information

Direct Link to Project Webpage:

<https://www.cityofpaloalto.org/news/displaynews.asp?NewsID=5105&TargetID=319>