

## PAD & REINFORCING BAR DIMENSIONS

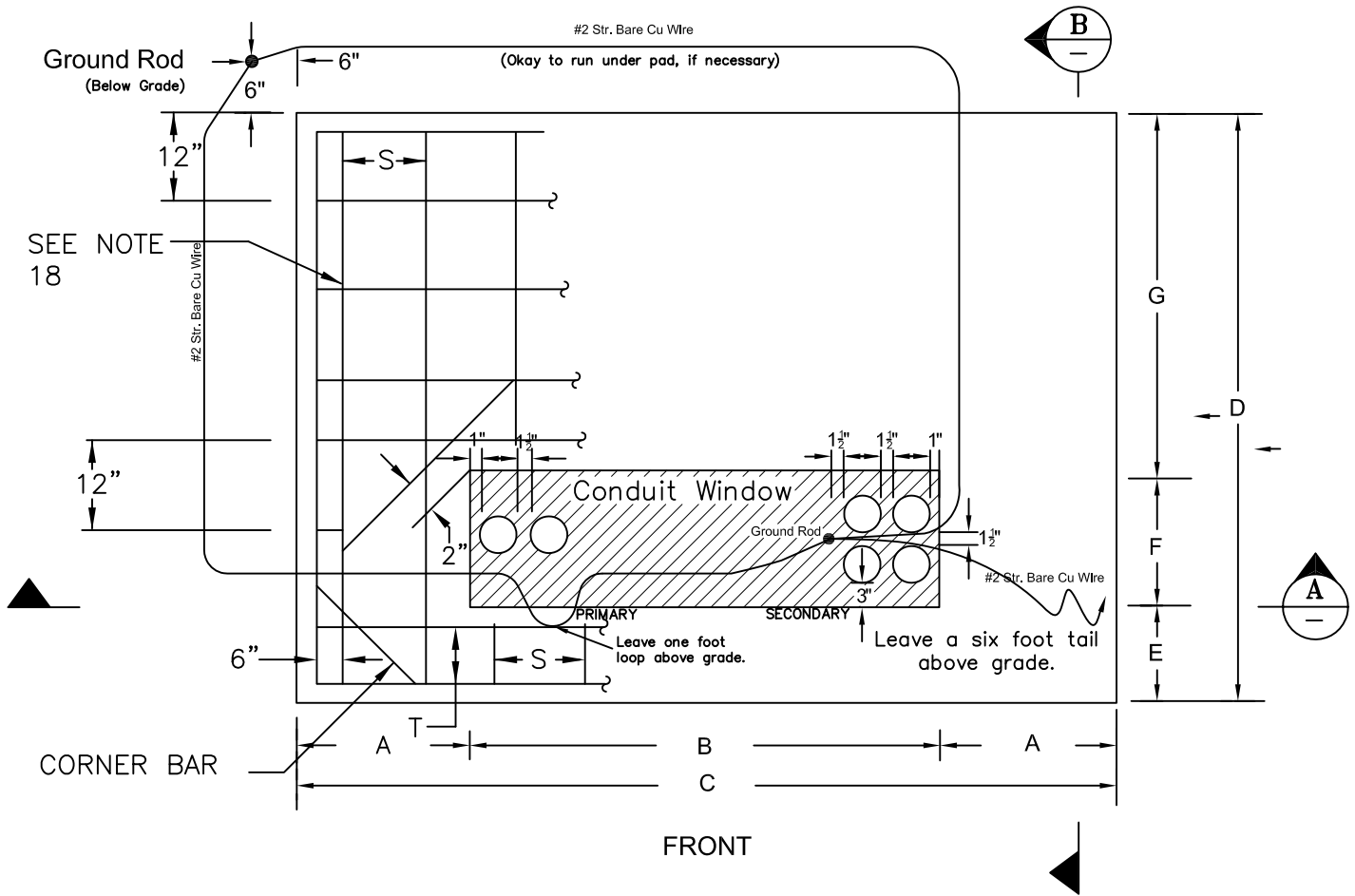

TRANSFORMER		PAD DIMENSIONS, INCHES										
KVA	LBS(APROX)	A	B	C	D	E	F	G	H**	J**	S**	T**
* 25-75 1Ø	2500	12	30	54	60	10	15	35	12	6	12	6
75-112.5	3000-4500	20	40	80	74	15	20	39	12	6	12	10
150-500	4000-6500	20	48	88	74	15	20	39	12	6	12	10
750-1000	9000-11000	26	48	100	100	15	24	61	15	9	6	10
1500	13000	26	56	108	114	15	24	75	15	9	4	10
2000-2500	20000	29	56	114	120	15	24	81	15	9	4	10

\* THIS PAD SHOULD BE USED FOR SINGLE PHASE 75 KVA TRANSFORMERS,  
NOT THREE PHASE 75 KVA TRANSFORMERS.

\*\* REQUIREMENT FOR PADS POURED IN PLACE

REV	DATE	DESCRIPTION	APPR
11	6-15	REVISED NOTES, GENERAL REVISION	TT
10	2-09	GENERAL REVISION	TT
9	7-97	REVISED NOTES	MJ/TF
8	1-97	REVISED PAD DIMENSIONS	PV/TL
7	5-96	REVISED PAD DIMENSIONS	PV/TL

APPROVED 1994

ENGINEERING STANDARD

**CONCRETE TRANSFORMER PAD**

**CITY OF PALO ALTO  
CALIFORNIA**

NTS	<b>DT-SS-C-1005</b>	1 OF 4
SCALE	STANDARD NO.	SHEET NO.

Original Design and Approved by Engineering Manager  
 DRAWN BY MJ  
 CHECKED BY PEV

SECTION **A**

SECTION **B**

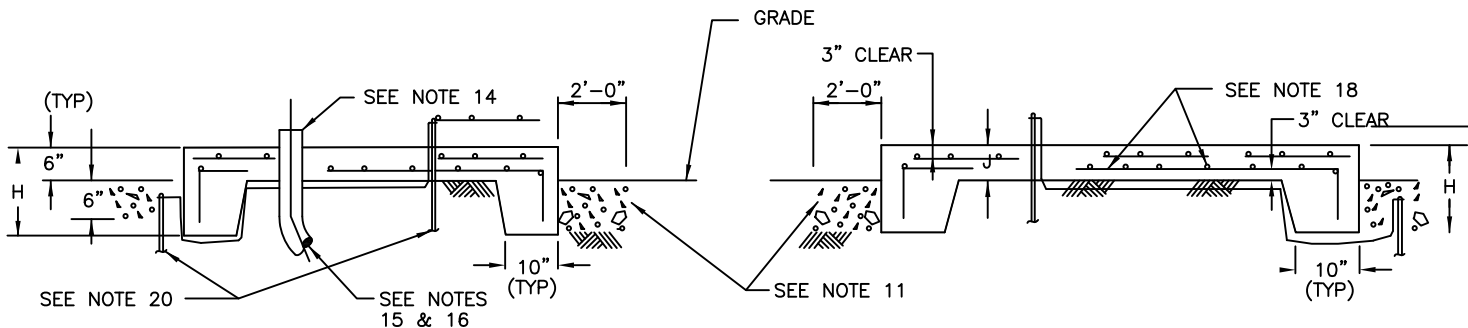

DETAILS FOR PADS POURED IN PLACE

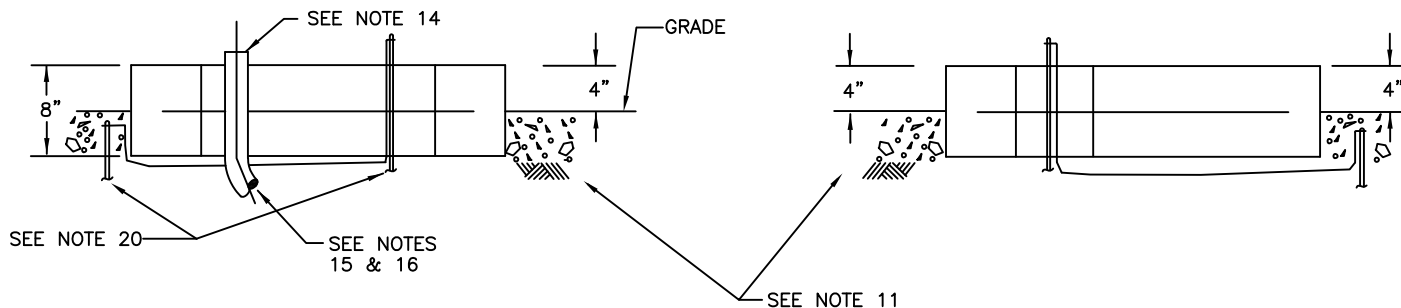

DETAILS FOR PRECAST PADS

APPROVED 1/1994

ENGINEERING STANDARD

CONCRETE TRANSFORMER PAD

CITY OF PALO ALTO  
CALIFORNIA

11	6-15	CORRECTED REFERENCE NUMBERS	TT
5	2-09	GENERAL REVISION	TT
4	7-99	REVISED NOTES / ADDED NOTE 19	TF/SF
3	2-88	GENERAL NOTES	
REV	DATE	DESCRIPTION	APPR
NTS		DT-SS-C-1005	2 OF 4
SCALE		STANDARD NO.	SHEET NO.

*Original Design and Approved by Engineer*  
 DRAWN BY MJ MJ  
 CHECKED BY PEV

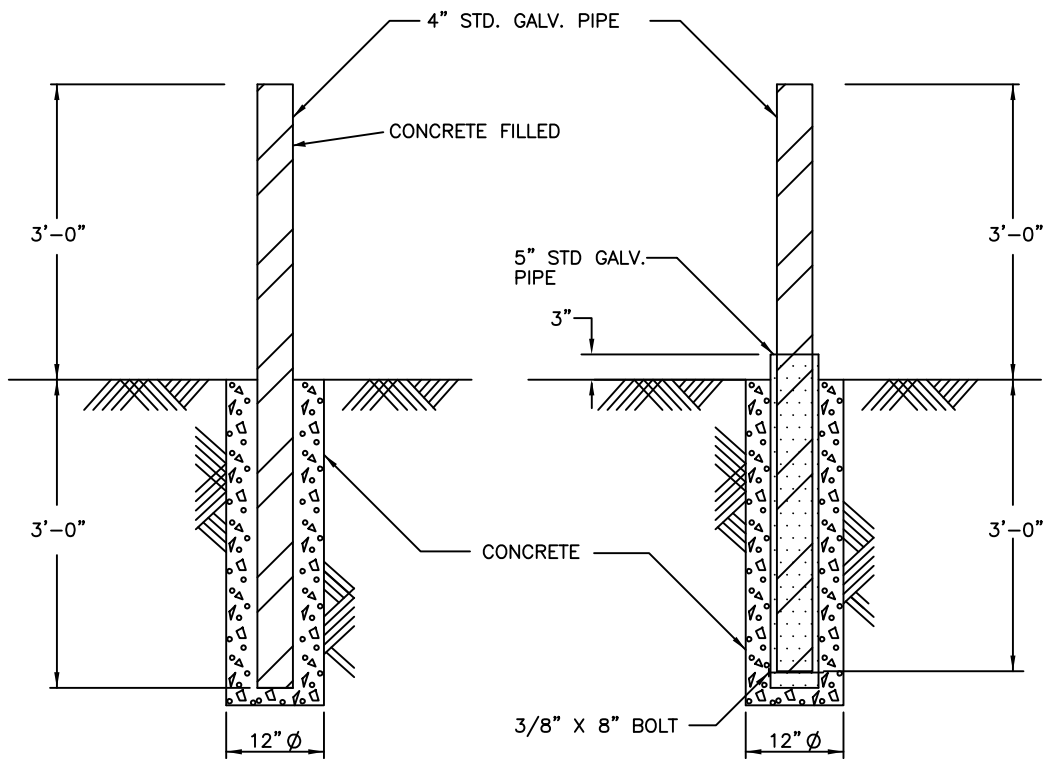

**DETAIL 1**  
PERMANENT GUARD POST

**DETAIL 2**  
REMOVABLE GUARD POST

USE REMOVABLE GUARD POSTS WHEN INSTALLED LESS THAN 8 FEET IN FRONT OF EQUIPMENT DOORS OR WHERE PERMANENT POSTS WOULD OBSTRUCT ACCESS FOR INSTALLATION OR MAINTENANCE.

GUARD POST INSTALLATION MUST BE COORDINATED WITH CONDUIT INSTALLATION TO AVOID CONFLICTS.

CONTACT CPAU ENGINEERING OR UNDERGROUND INSPECTOR FOR GUARD POST PLACEMENT LOCATIONS DETAIL.

APPROVED 3/1994

ENGINEERING STANDARD

CONCRETE TRANSFORMER PAD

CITY OF PALO ALTO  
CALIFORNIA

REV	DATE	DESCRIPTION	APPR
5	2-09	GENERAL REVISION	TT
3	2-88	GENERAL REVISION	
NTS		DT-SS-C-1005	3 OF 4
SCALE		STANDARD NO.	SHEET NO.

ENGR. MANAGER  
EOR  
DRAWN  
CHECKED  
PEV

*Original Signed and Approved by Engineering Manager*

