

Tree Technical Manual

CITY OF PALO ALTO

Standards & Specifications
Palo Alto Municipal Code, Chapter 8.10.030



Photograph by Alvin Dockter

June, 2001 First Edition

Department of Planning and Community Environment

Published by
The City of Palo Alto
Department of Planning and Community Environment
250 Hamilton Avenue
Palo Alto, CA 94301
Phone 650-329-2441
Fax 650-329-2154

First Edition June, 2001

World Wide Web Version
This document is available on the
City of Palo Alto's website:
<http://www.city.palo-alto.ca.us/trees>

Cover Photo
In 1997, Palo Altans celebrated their love for trees by enacting a tree preservation ordinance. This cover photo shows citizens enjoying the shade of a grand Valley Oak protected by ordinance and native to our region. Embracing the preservation of these trees demonstrates our investment in the future.
Photo by Alvin Dockter

CITY OF PALO ALTO
TREE TECHNICAL MANUAL
 STANDARDS AND SPECIFICATIONS

Palo Alto Municipal Code, Chapter 8.10.030

**Prepared for the City Manager
 by Dave Dockter, Managing Arborist**

Table of Contents

TABLE OF CONTENTS **i**

INTENT AND PURPOSE **xi**

INTRODUCTION - Use of the Manual **xiii**

Palo Alto’s Regulated Trees xiii

Palo Alto Municipal Code xiii

Protected Categories xiv

Required practices xiv

Recommended practices xiv

Definitions xiv

Appendices xv

Assumptions and limiting conditions xv

SECTION 1.00 DEFINITIONS **1-1**

SECTION 2.00 PROTECTION OF TREES

DURING CONSTRUCTION **2-1**

Introduction 2-1

2.10 Tree Protection and Preservation Plan **2-1**

2.15 Pre-construction requirements **2-2**

Site plan 2-2

Verification of tree protection 2-2

Pre-construction meeting 2-2

Protective tree fencing 2-2

Size and type of fence 2-2

Area to be fenced 2-2

Tree protection zone 2-4

Activities prohibited 2-4

Activities permitted or required 2-5

Erosion control 2-5

Tree pruning, surgery and removal 2-5

Pruning limitations 2-5

Minimum pruning 2-5

Maximum pruning 2-5

Tree workers 2-5

Surgery 2-6

Tree removal procedure 2-6

Tree removal 2-6

Stump removal 2-6

2.20 Activities during construction and demolition near trees **2-6**

Soil compaction 2-6

| | |
|--|-------------|
| Grading limitations | 2-6 |
| Trenching, excavation and equipment | 2-7 |
| Notification | 2-7 |
| Root severance | 2-7 |
| Excavation | 2-7 |
| Heavy equipment | 2-7 |
| Structural design | 2-7 |
| Basement excavations | 2-8 |
| Tunneling & directional drilling | 2-8 |
| Public Utilities | 2-10 |
| Street Trees | 2-10 |
| Injury mitigation | 2-11 |
| Irrigation program | 2-11 |
| Dust control program | 2-11 |
| Soil compaction damage | 2-11 |
| 2.25 Damage to trees | 2-12 |
| Reporting | 2-12 |
| Root injury | 2-12 |
| Bark or trunk wounding | 2-13 |
| Scaffold branches or leaf canopy injury | 2-13 |
| Penalty for damage to street trees | 2-13 |
| 2.30 Inspections | 2-14 |
| Inspection of tree fences | 2-14 |
| Pre-construction meeting | 2-14 |
| Inspection of rough grading | 2-14 |
| Monthly inspections | 2-14 |
| Special activity within the tree protection zone | 2-14 |
| Landscape Architect inspection | 2-14 |
| 2.40 Pavement and hardscape | |
| conflicts with tree roots | 2-14 |
| Removal and replacement of pavement or sidewalk | 2-15 |
| Alternative methods to prevent root cutting | 2-15 |
| Avoiding conflict | 2-15 |
| Alternative base course materials | 2-16 |
| SECTION 3.00 REMOVAL, REPLACEMENT & | |
| PLANTING OF TREES | 3-1 |
| Introduction | 3-1 |
| 3.05 Tree removal | 3-1 |
| Allowable removal | 3-1 |
| Permit application | 3-1 |
| Tree removal checklist | 3-2 |
| Hazard trees | 3-2 |
| 3.10 When tree replacement is required | 3-2 |
| Protected Trees | 3-2 |
| Designated Trees | 3-2 |
| Street Trees | 3-2 |

| | |
|--|------------|
| 3.15 Alternatives when trees cannot be replaced onsite | 3-3 |
| Responsibility | 3-3 |
| Development | 3-3 |
| Other Situations | 3-3 |
| 3.20 Tree canopy replacement standard for onsite tree replacement | 3-3 |
| Species | 3-3 |
| Location | 3-3 |
| Size and Number | 3-4 |
| 3.25 Tree value replacement standard | 3-5 |
| When does tree value apply? | 3-5 |
| 3.26 Security deposits | 3-5 |
| 3.30 Tree and shrub planting specifications | 3-5 |
| 3.35 Planting stock and materials | 3-5 |
| Quality | 3-5 |
| Miscellaneous materials | 3-6 |
| Tree stakes | 3-6 |
| Tree ties | 3-6 |
| Bark mulch | 3-6 |
| Root control barriers | 3-6 |
| Tree grates | 3-6 |
| 3.40 Planting site preparation | 3-6 |
| Soil preparation and conditioning | 3-6 |
| Planter pit | 3-6 |
| Trees in a confined planter pit or sidewalk area | 3-6 |
| Trees in all other areas | 3-7 |
| Height of root ball | 3-7 |
| Drainage | 3-7 |
| Poor drainage | 3-7 |
| Mitigation measures for locations with poor drainage | 3-7 |
| French drain | 3-7 |
| Drain tiles | 3-7 |
| Drain holes | 3-7 |
| Planting percolation test | 3-7 |
| Aeration tubes for trees | 3-7 |
| Street trees | 3-7 |
| Other trees | 3-7 |
| 3.45 Planting the tree | 3-8 |
| Perform percolation test | 3-8 |
| Depth | 3-8 |
| Container and roots | 3-8 |
| Placing the tree | 3-8 |
| Filling the hole | 3-8 |
| Staking | 3-8 |
| Berm, mulch and water | 3-9 |

| | |
|---|------------|
| 3.50 Planting in difficult soil conditions | 3-9 |
| Turf areas | 3-9 |
| Alternate specifications | 3-9 |
| Engineered soil | 3-9 |
| | |
| SECTION 4.00 HAZARDOUS TREES | 4-1 |
| Introduction | 4-1 |
| Tree hazard responsibility | 4-1 |
| Recognizing tree hazards | 4-1 |
| | |
| 4.10 Emergency removal conditions | 4-1 |
| Abatement | 4-1 |
| Authorization | 4-1 |
| | |
| 4.20 Criteria used by the City to determine if a tree is hazardous | 4-2 |
| Definition of Hazardous | 4-2 |
| ISA - Hazard Evaluation form | 4-2 |
| Authorization | 4-2 |
| | |
| 4.25 Determining a tree's hazard rating | 4-2 |
| Rating the failure potential | 4-2 |
| Target Rating | 4-3 |
| Additional factors | 4-3 |
| | |
| 4.30 Tree evaluation checklist | 4-3 |
| Hazard evaluation questionnaire | 4-3 |
| | |
| 4.40 Hazard reduction and prevention | 4-4 |
| Safe tree checklist | 4-5 |
| | |
| SECTION 5.00 TREE MAINTENANCE GUIDELINES | 5-1 |
| Introduction | 5-1 |
| | |
| 5.05 Care of regulated trees | 5-1 |
| | |
| 5.10 Prohibited acts | 5-1 |
| Excessive pruning | 5-1 |
| Topping | 5-1 |
| Other prohibited actions | 5-1 |
| | |
| 5.15 Standards for pruning regulated trees | 5-1 |
| Specifications | 5-2 |
| Industry standards | 5-2 |
| | |
| 5.20 Pruning mature trees | 5-2 |
| Types of pruning | 5-2 |
| Tree injury | 5-2 |
| Timing of pruning | 5-2 |
| | |
| 5.25 Pruning distressed trees | 5-3 |
| Injury or disturbance | 5-3 |
| Neglect | 5-3 |

| | |
|--|------------|
| 5.30 Pruning young trees | 5-3 |
| 5.40 Fertilizing standards | 5-3 |
| Specifications | 5-3 |
| Method of application | 5-3 |
| Material and rates | 5-3 |
| Amount | 5-4 |
| Timing | 5-4 |
| 5.45 Watering schedule | 5-4 |
| New trees | 5-4 |
| Mature trees | 5-4 |
| Watering methods | 5-4 |
| Automated watering systems | 5-4 |
| Bubbler heads | 5-5 |
| Drip-loop system | 5-5 |
| Hand watering systems | 5-5 |
| Flood watering | 5-5 |
| Sub-surface injections | 5-5 |
| Soaker hose | 5-5 |
| Wetting agent | 5-5 |
| Amount | 5-5 |
| 5.50 Soil improvement | 5-5 |
| Aeration | 5-5 |
| Vertical mulching | 5-5 |
| Radial Trenching | 5-6 |
| Soil-fracturing | 5-6 |
| Subsurface injection | 5-6 |
| Drainage | 5-6 |
| 5.60 Insect and disease control | 5-6 |
| Insects | 5-6 |
| Disease - above ground | 5-6 |
| Disease - below ground | 5-7 |
| Foliar disease | 5-7 |
| 5.80 Fruit control | 5-7 |
| 5.90 Fire Protection: | |
| Keeping the Open Space and Community Safe | 5-8 |
| 5.95 Tips for selecting an arborist | 5-8 |
| Who should you look for? | 5-8 |
| Contract for services | 5-9 |
| Using arborists for proactive care | 5-10 |
| SECTION 6.00 TREE REPORTS | 6-1 |
| Introduction | 6-1 |
| 6.00 Tree reports | 6-1 |
| When a written report is required | 6-1 |
| Who may prepare the report | 6-1 |

| | |
|--|------------|
| 6.05 Report for an Individual tree removal permit | 6-1 |
| Tree removal procedure | 6-1 |
| Submittals | 6-1 |
| Application | 6-1 |
| Filing fee | 6-1 |
| Arborist report | 6-1 |
| Written authorization | 6-1 |
| 6.10 Type of report: letter format | 6-2 |
| Removal | 6-2 |
| Development | 6-2 |
| 6.15 Letter report - submittals | 6-2 |
| Standard information | 6-2 |
| Specific situations | 6-2 |
| 6.20 Type of report: tree survey format | 6-2 |
| 6.25 Survey report - submittals | 6-3 |
| Items to include | 6-3 |
| Appraised value | 6-3 |
| 6.30 Tree protection and preservation report | 6-3 |
| Scope & construction phasing | 6-3 |
| Tree protection zone | 6-3 |
| 6.35 Site Plan | 6-4 |
| Disclosure of all trees on and near the site | 6-4 |
| Plans submitted to the City | 6-4 |
| Tree protection shown on plans | 6-4 |
| 6.40 Tree Appraisal | 6-4 |
| 6.45 Appraisal methods | 6-4 |
| The replacement cost method | 6-4 |
| The trunk formula method | 6-5 |

APPENDICES

- A: Palo Alto Municipal Code Chapter 8.10, Tree Preservation & Management Regulations
- B: Tree City - USA
- C: ISA Hazard Evaluation Form
- D: List of Inherent Failure Patterns for Selected Species (Reference source)
- E: ISA Tree Pruning Guidelines
- F: Tree Care Safety Standards, ANSI Z133.1-1994 (Reference source)
- G: Pruning Performance Standards, ANSI A300-1995 (Reference source)
- H: Tree Planting Details, Diagram 503 & 504
- I: Tree Disclosure Statement
- J: Palo Alto Standard Tree Protection Instructions
- K: Tree Protection Detail, Public Works Detail #505
- L: Procedures for Landscaping Under Native Oaks
- M: Tree Removal - Procedure Checklist
- N: Heritage Tree Application Checklist

Acknowledgments

This section acknowledges those persons involved in the preparation of the *Tree Technical Manual*.

Principal Author

Dave Dockter, Managing Arborist, Planning Division
Department of Planning and Community Environment, City of Palo Alto, CA
Member of the American Society of Consulting Arborists (ASCA) and
the International Society of Arboriculture, (ISA) Certified Arborist WC-0351

Technical City Staff Advisors

Dave Sandage, Managing Arborist, Public Works Operations
Eugene Segna, Public Works Arborist
Steve Scott, Public Works Arborist

Other City Staff

Ed Gawf, Director of Planning and Community Environment
Lisa Grote, Chief Planning Official
Fred Herman, Chief Building Official
John Lusardi, Planning Manager
Wynne Furth, Senior Assistant City Attorney
Jim Harrington, Public Works Senior Engineer
Greg Scoby, Utilities Senior Engineer
Jim Slear, Utilities Gas Supervisor
Roland Ekstrand, Water-Gas-Wastewater, Utilities Senior Engineer
John Ballard, Sidewalks, Public Works Supervisor
John Cunningham, Sidewalks, Public Works Assistant Engineer
Kate Rooney, Park Supervisor

Special Thanks & Recognition

Barrie Coate, Barrie Coate and Associates, Horticulturist, ASCA
Ray Morneau, Arborist, ISA Certified WC-0132
Scott Cullen, Registered Consulting Arborist, ASCA
Nancy Lytle, Palo Alto City Council Member
Nate Cradle, Landscape Specialist, Caltrans, State of California
Cordelia Hill, APA, Royston, Hanamoto, Alley & Abbey, Landscape Architects &
Planners
Marni Barnes, Landscape Architect
Bruce Hagen, Urban Forester, State of California
RDC interactive, Inc.
Canopy: Trees for Palo Alto
and
The International Society of Arboriculture--
for authorization to reprint guidelines from *Tree Pruning Guidelines* and the *Tree
Hazard Evaluation Form, 2nd Edition* from the *Photographic Guide to the Evaluation
of Hazard Trees in Urban Areas*.

References

This section references sources of information for further review or which was consulted in the preparation of the *Tree Technical Manual*.

- American National Standards Institute (ANSI). *Safety Requirements for Tree Care Operations*. ANSI Z133.1-1994. New York: American National Standards Institute (ANSI), 1994.
- American National Standards Institute (ANSI). *Specifications for Acceptance of Nursery Trees at the Time of Delivery*. ANSI 760.1. New York: American National Standards Institute (ANSI), 1996.
- American National Standards Institute (ANSI). *Performance Specifications of the Pruning of Trees Shrubs & Other Woody Shrubs*. ANSI A-300 -1998. New York: American National Standards Institute (ANSI), 1998.
- Council of Tree & Landscape Appraisers. *Guide For Plant Appraisal, 9th Edition*. Savoy, IL: International Society of Arboriculture (ISA), 2000.
- Matheny, Nelda P., James R. Clark. *Evaluation of Hazard Trees in Urban Areas I*. Savoy, IL: International Society of Arboriculture (ISA), 1991.
- Matheny, Nelda P., James R. Clark. *Evaluation of Hazard Trees in Urban Areas II*. Savoy, IL: International Society of Arboriculture (ISA), 1994.
- Matheny, Nelda P., James R. Clark. *Trees and Development : A Technical Guide To Preservation of Trees During Land Development*. International Society of Arboriculture: Champaign, IL, 1998.
- National Arbor Day Foundation. *Tree City - USA*. Bulletin No. 1-50.
- National Arbor Day Foundation. *How to Protect Trees During Underground Work*. Tree City USA, Bulletin No. 35.
- Shigo, Alex. *Tree Hazards Brochure*. 1997.
- University of California. *Recognizing Tree Hazards: A Photographic Guide for Homeowners*. Agriculture and Natural Resources Communications Services. Publication 21584. 1999.
- University of California Cooperative Extension Service. *Plant List & Procedures for Landscaping Under Native Oaks*. HortScript No. 11, March, 1995.
- American Society of Consulting Arborists, Dorothy Abeyta, *Guide to Report Writing for Consulting Arborists*. Savoy, IL: International Society of Arboriculture (ISA), 1995.



END OF SECTION

THIS PAGE INTENTIONALLY LEFT BLANK



“In Palo Alto, it’s the trees!”



CITY OF PALO ALTO
TREE TECHNICAL MANUAL
STANDARDS AND SPECIFICATIONS

notes:

Intent & Purpose

The City of Palo Alto is endowed with a large population of trees, including magnificent individual trees, groupings of trees, native oaks, redwoods and heritage trees which give the City a unique visual character. Trees are a source of shade, air conditioning and other environmental benefits, and yield both a high quality of life and economic benefits to the community, including enhanced property values. The City is dedicated to the planting and protection of one of its greatest natural resources. Palo Alto is recognized by the State of California and National Arbor Day Foundation as a Tree City-USA.

Sustaining trees in Palo Alto's developed environment presents a challenge, requiring careful planning and vigilant maintenance. The vestiges of the City's original abundant oak and redwood environs, so well adapted to much of this region, are increasingly vulnerable after more than a century of development. Meeting this challenge, the Tree Preservation and Management Regulations were codified in 1997, adding Chapter 8.10 to Title 8 - Trees and Vegetation of the Palo Alto Municipal Code. The ordinance complements the City's Tree Management Program for street and parkland trees.

Tree Preservation and Management Regulations are the City's primary regulatory tool to provide for orderly protection of specified trees, to promote the health, safety, welfare, and quality of life for the residents of the City, to protect property values and to avoid significant negative impacts on adjacent properties. By assuring preservation and protection through regulations and standards of care, these resources will remain significant contributions to the landscape, streets and parks — and continue to help define the unique character of Palo Alto.

The *Tree Technical Manual* is a separately published document issued by the City Manager, through the Departments of Planning and Community Environment and Public Works to establish specific technical regulations, standards and specifications necessary to implement the Ordinance, and to achieve the City's tree preservation goals. These goals are intended to provide consistent care and serve as benchmark indicators to measure achievement in the following areas:

- ▶ Insure and promote preservation of the existing tree canopy cover within the City limits
- ▶ Provide standards of maintenance required for protected and city-owned trees
- ▶ Provide a standardized content for tree reports required by the City
- ▶ Establish criteria for determining when a tree is unsafe and a possible threat to the public health, safety and welfare
- ▶ Provide standards for the replacement of trees that are permitted to be removed
- ▶ Increase the survivability of trees during and after construction events by providing protection standards and best management practices

THIS PAGE INTENTIONALLY LEFT BLANK

CITY OF PALO ALTO
TREE TECHNICAL MANUAL
STANDARDS AND SPECIFICATIONS

notes:

Introduction – Use of the Manual

I. PALO ALTO'S REGULATED TREES

A. Palo Alto Municipal Code

Title 8 protects specific trees on public or private property from removal or disfigurement. The *Tree Technical Manual* establishes procedures and standards for the purpose of encouraging the preservation of trees. Trees that fall within the following three categories are considered “*Regulated Trees*”, and must be maintained in accordance with the standards and regulations contained in the *Manual*. A permit from the Planning or Public Works Department is required prior to removal of a *Regulated Tree*. Trees that are not in any of these categories may be maintained or removed without City review or approval.

▶ **Protected Trees**

All Coast Live Oak, *Quercus agrifolia*, Valley Oak, *Quercus lobata* trees that are 11.5-inches or greater in diameter (36-inches in circumference measured at 54-inches above natural grade) and Coast Redwood, *Sequoia sempervirens* trees that are 18-inches or greater in diameter (57-inches in circumference measured at 54-inches above natural grade) and Heritage Trees, individual trees of any size or species designated as such by City Council. Property owners may nominate a tree that has distinctive characteristics such as being of great age or size, unique form or other historical significance. A list of designated heritage trees is kept at the Planning Division offices.

PAMC 8.10



IMAGE 1-1

Oak Tree Identification

The Valley Oak leaf on the right has deeply-lobed margins. The Coast Live Oak leaf on the left is oval-shaped with stiff prickly points.



IMAGE 1-2

Redwood Tree Identification

The redwood tree leaf has needles on opposite sides of the stem with stiff prickly points. Small cones may also be present.

▶ **Street Trees**

All trees growing within the street right-of-way (publicly-owned), outside of private property. In some cases, property lines lie several feet behind the sidewalks (see *Image 2.20-3*). A permit from the Public Works Department is required prior to any work on or within the dripline of any ‘*street tree*’.

PAMC 8.04.020

notes:

▶ **Designated Trees**

All trees, when associated with a development project, that are specifically designated by the City to be saved and protected on a public or private property which is subject to a *discretionary development* review; such as a variance, home improvement exception, architectural review, site and design, subdivision, etc. Approval from the Planning Division is required to remove a designated tree.

B. Protected Categories

Throughout the *Manual*, the designation of *Regulated Trees* shall refer to all those trees or groups of trees included in the above three categories.

II. REQUIRED PRACTICES

- ▶ The Required Practices are to be implemented by the property owner, project applicant, contractor or designee - and are the minimum standards by which the care of a *Regulated Tree* is to be administered.
- ▶ The Required Practices category identified throughout the *Manual* are reasonable measures that are consistent with best management practices in the tree care industry and are intended to promote healthy, structurally sound trees.
- ▶ In all such cases, the Director of Planning & Community Environment, Public Works or *City Arborist* shall, if justified by field conditions such as conflict with utilities or a public nuisance, have the discretion to modify or add to any condition, practice or standard mentioned within the *Manual*.

III. RECOMMENDED PRACTICES

- ▶ The Recommended Practices identified throughout the *Manual* are not mandatory, but provide additional proactive measures for the care of trees, such as fertilizing, reducing a tree hazard, protection from specific *disturbances* or procedures for planting trees on problem sites.
- ▶ Note: A *recommended practice* may be required if it is so specified within the 'conditions of approval' for a development project or mitigation for injury or disturbance.
- ▶ In all cases, the Director of Planning & Community Environment, Public Works or *City Arborist* shall, if justified by changing field conditions such as conflict with utilities, have discretion to modify, redesignate or add to any condition, practice or standard mentioned within the *Manual*.

IV. DEFINITIONS

Certain terms that are unique to the arboricultural or construction industry are defined to provide a uniform understanding of the terms and concepts used and mentioned in this document. Words that are defined are noted in *italics* throughout the document

and are found in the Definitions, Section 1.00 of both the *Manual*, and in the *Tree Preservation and Management Regulations*, Chapter 8.10.020 of the Palo Alto Municipal Code (see *Appendix A*).

notes:

V. APPENDICES

The appendices at the end of this *Manual* provide supplemental information referenced within the *Manual* and sources of technical information for specific or unusual situations.

VI. ASSUMPTIONS AND LIMITING CONDITIONS

- ▶ No responsibility is assumed by the City of Palo Alto for matters legal in character regarding this *Manual*. Any legal description that may be provided is assumed to be correct.
- ▶ Care has been taken to obtain reasonable information from reliable sources for this *Manual*.
- ▶ Visual aids within this *Manual*, such as sketches, diagrams, graphs, photos, are not necessarily to scale and should not be construed as engineered data for construction.
- ▶ This *Manual* has been crafted to conform with current standards of care, best management practices, evaluation and appraisal procedures, diagnostic and reporting techniques and sound arboricultural practices as recommended by the sources listed in the References section.



END OF SECTION

THIS PAGE INTENTIONALLY LEFT BLANK

CITY OF PALO ALTO
TREE TECHNICAL MANUAL
STANDARDS AND SPECIFICATIONS

notes:

SECTION 1.00 DEFINITIONS

For the purposes of this *Manual* and interpretation of regulations, the following definitions shall apply:

1. Appraisal (see *Tree Appraisal, Section 1.34*).
2. Building Area means the area of a parcel that (1) upon which, under applicable zoning regulations, a structure may be built without a variance, design enhancement exception, or home improvement exception or; (2) is necessary for the construction of primary access to structures located on the parcel, where there exists no feasible means of access which would avoid protected trees. On single-family residential parcels, the portion of the parcel deemed to be the building area access shall not exceed ten (10) feet in width. PAMC 8.10.020
3. Building Footprint means the two-dimensional configuration of a building's perimeter boundaries measured on a horizontal plane at grade level. PAMC 8.10.020
4. Certified Arborist is an individual who has demonstrated knowledge and competency through obtainment of the current International Society of Arboriculture arborist certification, or who is a member of the American Society of Consulting Arborists. A *certified arborist* can be found in the yellow pages of the local telephone book, by contacting Canopy: Trees for Palo Alto at (650) 964-6110 (www.canopy.org) or the Western Chapter of the ISA at (916) 641-2990 (www.wcisa.org).
5. City Arborist means the person designated as such by the Director of Planning and Community Environment or the Director of Public Works.
6. Compaction means compression of the soil structure or texture by any means that creates an upper layer that is impermeable ('cap'). *Compaction* is injurious to roots and the health of a tree (see *Soil Compaction Damage, Section 2.20*).
7. Dangerous see Hazardous.
8. Dead Tree means a tree that is dead or that has been damaged beyond repair or is in an advanced state of decline (where an insufficient amount of live tissue, green leaves, limbs or branches, exists to sustain life) and has been determined to be such by a *certified arborist*. If the tree has been determined to be dead, *removal* is permitted under Section 8.10.050 of the Palo Alto Municipal Code.
9. Designated Tree means all trees that are specifically designated by the City to be saved and protected on a public or private property which is subject to discretionary development approval (see *Discretionary Development Approval, Section 1.11*), such as a variance, home improvement exception, architectural review, site and design, subdivision, etc. Designated trees are to be indicated on approved building permit or landscape plans. PAMC 16.48.120

notes:

10. Diameter at Breast Height (DBH) or Diameter at Standard Height means the diameter of the perimeter tree trunk at four and one-half feet (or 54 inches) above natural grade level. See '*Protected trees*' for diameters of different species. The diameter may be calculated by using the following formula: $DBH = \text{circumference at 4.5-feet} \times 3.142$ ($D = C \times \pi$). To determine the DBH of multi-trunk trees or measuring trees on slopes, consult the current *Guide for Plant Appraisal*, published by the Council of Tree and Landscape Appraisers.
11. Director means the Director of Planning and Community Environment or the Director's designee, unless otherwise specified in the *Manual*.
12. Discretionary Development Approval means a planned community zone, subdivision, use permit, variance, home improvement exception, design enhancement exception, or Architectural Review Board approval.
13. Disturbance refers to all of the various activities from construction or development that may damage trees.
14. Dripline Area means the area within X distance from the trunk of a tree, measured from the perimeter of the trunk of the tree at 54-inches above natural grade, where X equals a distance ten times the diameter of the trunk at 54-inches above natural grade.
15. Excessive Pruning means: removing in excess, one-fourth (25 percent) or greater, of the functioning leaf, stem or root area. Pruning in excess of 25 percent is injurious to the tree and is a prohibited act. *Excessive pruning* typically results in the tree appearing as a 'bonsai', 'lion's-tailed', 'lolly-popped' or overly thinned (see '*Standards for Pruning Protected Trees*', Section 5.15).
 - ▶ Unbalanced Crown. *Excessive pruning* also includes removal of the leaf or stem area predominantly on one side, topping, or excessive tree canopy or crown raising. Exceptions are when clearance from overhead utilities or public improvements is required or to abate a *hazardous* condition or a *public nuisance*.
 - ▶ Roots. *Excessive pruning* may include the cutting of any root two (2) inches or greater in diameter and/or severing in excess of 25 percent of the roots.
16. Hazardous Tree refers to a tree that possesses a structural defect which poses an imminent risk if the tree or part of the tree that would fall on someone or something of value (target)(see *Determining if a tree is Hazardous*, Section 4.00).
 - ▶ Structural defect means any structural weakness or deformity of a tree or its parts. A tree with a structural defect can be verified to be *hazardous* by a *certified arborist* and confirmed as such by the City Arborist. For the purpose of tree removal information required by the City, the tree report shall include a completed *ISA-TREE HAZARD EVALUATION FORM*, or an approved equivalent. The *City Arborist* retains discretionary right to approve or amend a *hazardous* rating, in writing, and recommend any action that may reduce the condition to a less-than significant level of hazard. If the tree has been determined to be *hazardous*, *removal* of the tree is permitted under Section 8.10.050 of the Municipal Code.

- ▶ A *'target'* may mean people, vehicles, structures or property, such as other trees or landscape improvements. A tree may not be a hazard if a *'target'* is absent within the falling distance of the tree or it's parts (e.g., a substandard tree in a non-populated area away from pedestrian pathways may not be considered a hazard).
17. Injury means a wound resulting from any activity, including but not limited to *'excessive pruning'*, cutting, *trenching*, excavating, altering the grade, paving or *compaction* within the *tree protection zone* of a tree. *Injury* shall include bruising, scarring, tearing or breaking of roots, bark, trunk, branches or foliage, herbicide or poisoning, or any other action foreseeably leading to the death or permanent damage to tree health.
 18. Monthly Inspection Report means a written report prepared by the property owner, *project arborist*, architect, developer, landscape architect, builder, applicant or other designated individual to document that a monthly tree inspection or any other required measure has been accomplished. The *project arborist* shall perform a site inspection to monitor the tree condition on a minimum interval of four weeks. The Planning Division Arborist shall be in receipt of the progress report during the first week of each calendar month until project completion at fax # (650) 329-2154.
 19. Project Arborist means a *certified arborist* (see *Certified Arborist, Section 1.4*) retained by a property owner or development applicant for the purpose of overseeing on-site activity involving the welfare of the trees to be retained. The *project arborist* shall be responsible for all reports, *appraisals*, tree preservation plans, or inspections as required.
 20. Protected Tree means:
 - ▶ All Coast Live Oak, *Quercus agrifolia*, Valley Oak, *Quercus lobata* that are 11.5-inches or greater in diameter (36-inches in circumference measured at 54-inches above natural grade) and Coast Redwood, *Sequoia sempervirens* trees that are 18-inches or greater in diameter (57-inches in circumference measured at 54-inches above natural grade) and Heritage trees, individual trees of any size or species designated by City Council having distinctive characteristics such as great age, large, unique form or possess historical significance (see *Introduction - Use of The Manual, Regulated Trees*).
 21. Protective Tree Fencing means a temporary enclosure erected around a tree to be protected at the boundary of the *tree protection zone*. The fence serves three primary functions: 1) to keep the foliage crown, branch structure and trunk clear from direct contact and damage by equipment, materials or *disturbances*; 2) to preserve roots and soil in an intact and non-compacted state; and 3) to identify the tree protection zone (see *Section 2.15 E*) in which no soil *disturbance* is permitted and activities are restricted. (*For size, type, area and duration of the fencing, see Protective Tree Fencing, Section 2.15.D*).
 22. Public Nuisance means either an individual tree or shrub on any private property or in any street, or a type or species apt to destroy, impair or otherwise interfere with any street improvements, sidewalks, curbs, *street trees*, gutters, sewers, or other public improvements, including above and below ground utilities.

notes:

PAMC 8.04.050 (b)

notes:

PAMC 8.10.020

23. Recommended Practice means an action, treatment, technique or procedure that may be implemented for superior care or preservation of trees. Recommended practices may be required under specific conditions of approval for *discretionary development* projects or *injury* mitigation.
24. Regulated Tree means any *Protected Tree*, *Street Tree* or *Designated Tree*.
25. Removal means any of the following:
 - ▶ Complete tree *removal* such as cutting to the ground or extraction of the tree.
 - ▶ Taking any action foreseeably leading to the death of a tree or permanent damage to its health or structural integrity, including but not limited to *excessive pruning*, cutting, girdling, poisoning, over watering, unauthorized relocation or transportation of a tree, or *trenching*, excavation, altering the grade, or paving within the *dripline* of the tree.
26. Required Practice means a mandatory action, treatment, technique or standard of care required to be implemented by the property owner, developer, contractor or designee for the preservation of trees
27. Root Buffer means a temporary layer of material to protect the soil texture and roots. The buffer shall consist of a base course of tree chips spread over the root area to a minimum of 6-inch depth, capped by a base course of 3/4-inch quarry gravel to stabilize 3/4-inch plywood on top. (see *Buffers*, Section 2.15.5 B).
28. Site Plan means a set of drawings (e.g. preliminary drawings, *site plan*, grading, demolition, building, utilities, landscape, irrigation, tree survey, etc.) that show existing site conditions and proposed landscape improvements, including trees to be removed, relocated or to be retained. *Site plans* shall include the following minimum information that may impact trees:
 - ▶ Surveyed tree location, species, size, *dripline area* (including trees located on neighboring property that overhang the project site) and *street trees* within 30-feet of the project site.
 - ▶ Paving, concrete, *trenching* or grade change located within the *tree protection zone*.
 - ▶ Existing and proposed utility pathways.
 - ▶ Surface and subsurface drainage and aeration systems to be used.
 - ▶ Walls, tree wells, retaining walls and grade change barriers, both temporary and permanent.
 - ▶ Landscaping, irrigation and lighting within dripline of trees, including all lines, valves, etc.
 - ▶ Location of other landscaping and significant features.
 - ▶ All of the final approved *site plan* sheets shall reference tree protection instructions (see also *Site Plan*, Section 6.35).

29. Soil Compaction means the compression of soil particles that may result from the movement of heavy machinery and trucks, storage of construction materials, structures, paving, etc. within the *tree protection zone*. Soil *compaction* can result in atrophy of roots and potential death of the tree, with symptoms often taking 3 to 10-years to manifest (see *Compaction, Section 2.20; and Aeration, Section 5.50 A*).
30. Soil Fracturing means the loosening of hard or compacted soil around a tree by means of a pneumatic soil probe (Gro-gun) that delivers sudden bursts of air to crack, loosen or expand the soil to improve the root growing environment.
31. Street Tree means any publicly owned tree, shrub or plant growing within the street right-of-way, outside of private property. In some cases, property lines lie several feet behind the sidewalks. A permit from the Public Works Department is required prior to any work on or around these trees. Check with the Public Works Department to verify prior to any work near a street tree (see *Introduction - Use of The Manual, Regulated Trees*).
32. Target is a term used to include people, vehicles, structures or something subject to damage by a tree.
- ▶ Note: A tree may not be a hazard if a “*target*” is absent within the falling distance of a tree or its parts (e.g., a defective tree in a non-populated area away from pathways may not be considered a hazard (see *Hazardous Tree, Section 1.15*).
33. Topping means the practice of cutting back large-diameter branches or truncating the main stem.
34. Tree Appraisal means a method of determining the monetary value of a tree as it relates to the real estate value of the property, neighborhood or community. When required, a *certified arborist* determines the appraisal by adjusting a tree’s basic value by its condition, location and species using the most recent edition of the *Guide for Plant Appraisal*, published by the Council of Tree and Landscape Appraisers (see *Tree Reports, Section 6.00*).
35. Tree Protection and Preservation Plan means a plan prepared by a *certified arborist* that outlines measures to protect and preserve trees on a project (see *Tree Protection and Preservation Plan, Section 2.10 and Reports, Section 6.30*). This plan shall include requirements for pre-construction; treatments during demolition and/or construction; establish a *tree protection zone* for each tree; tree monitoring and inspection schedule; and provide for continued maintenance of those trees after construction according to the requirements in this *Manual*.
36. Tree Protection Zone or (TPZ) means, unless otherwise specified by a *project arborist* or *City Arborist*, the area of temporary fenced tree enclosure (see *Protective Tree Fencing, Section 2.15.D, and Section 2.15.E*). Within the TPZ, roots that are critical for tree survival are typically found in the upper three foot soil horizon, and may extend beyond the *dripline area*. Protecting the roots in the TPZ is necessary to ensure the tree’s survival. The TPZ is a restricted activity zone where no soil *disturbance* is permitted, unless otherwise approved. TPZ must be identified for each tree and shown on all applicable improvement plans for a development project. Restricted and approved activities within the TPZ are outlined in Section 2.15.E.

notes:

PAMC 8.04.020

notes:

- ▶ Determining the TPZ. Unless otherwise specified, the approved minimum TPZ shall be formulated in the following way: the TPZ radius shall be 10 times the DBH of the trunk (see *Dripline area, Section 1.13*). For example: a 2-foot DBH = a 20-foot radius from the perimeter of the trunk—or a 40-foot TPZ. The *City Arborist* retains discretionary right to extend or modify the TPZ at any time.

37. Tree Report means a report submitted to the City for review that is prepared by a *certified arborist* retained by the property owner or agent.

- ▶ Tree Survey Report. In the case of a *discretionary development approval*, a tree survey report is required to provide information about all trees on the site including: inventory of all trees, location, species, size, condition, maintenance needs, potential impacts of disturbance, recommended mitigation measures, tree appraisal value, etc. (see *Tree Reports; Tree Protection and Preservation Plan and Tree Appraisal, Section 6.00*).
- ▶ Letter Report. A 'letter report' shall provide a brief description of the tree information to determine whether or not a tree is dead, hazardous or constitutes a public nuisance as defined in Palo Alto Municipal Code, Chapter 8.04.050 (2) (see *Tree Reports; Tree Protection and Preservation Plan and Tree Appraisal, Section 6.00*).

PAMC 8.10.030

38. Tree Technical Manual is this document.

39. Trenching means any excavation to provide irrigation, install foundations, utility lines, services, pipe, drainage or other property improvements below grade. *Trenching* within the TPZ is injurious to roots and tree health and is prohibited, unless approved. If *trenching* is approved within the TPZ, it must be in accordance with instructions and table outlined in this *Manual* (see *Trenching, Section 2.20.C, and Existing Paving and Hardscape Conflicts with Tree Roots, Section 2.40*).

40. Verification of Tree Protection means the *project arborist* shall verify, in writing, that all pre-construction conditions have been met (tree fencing, erosion control, pruning, etc.) and are in place. An initial inspection of protective fencing and written verification must be submitted to the *City Arborist* prior to demolition, grading or building permit issuance (see *Inspections, Section 2.30*).

41. Vertical Mulching means augering, hydraulic or air excavation of vertical holes within a tree's root zone to loosen and aerate the soil, typically to mitigate compacted soil. Holes are typically penetrated 4- to 6-feet on center, 2- to 3-feet deep, 2- to 6-inches in diameter and backfilled with either perlite, vermiculite, peat moss or a mixture thereof.



END OF SECTION

CITY OF PALO ALTO
TREE TECHNICAL MANUAL
STANDARDS AND SPECIFICATIONS

notes:

SECTION 2.00 - PROTECTION OF TREES DURING CONSTRUCTION

INTRODUCTION

The objective of this section is to reduce the negative impacts of construction on trees to a less than significant level. Trees vary in their ability to adapt to altered growing conditions. Mature trees have established stable biological systems in the preexisting physical environment. Disruption of this environment by construction activities interrupts the tree's physiological processes causing depletion of energy reserves and a decline in vigor, often resulting in the tree's death. Typically, this reaction may develop from one to twelve years or more after disruption. The tree protection regulations are intended to guide a construction project to insure that appropriate practices will be implemented in the field to eliminate undesirable consequences that may result from uninformed or careless acts, and preserve both trees and property values.

Typical negative impacts that may occur during construction include:

- ▶ mechanical *injury* to roots, trunk or branches
- ▶ *compaction* of soil, which degrades the functioning roots and inhibits the development of new ones and restricts drainage, which desiccates roots and enables water mold fungi to develop
- ▶ changes in existing grade which can cut or suffocate roots
- ▶ alteration of the water table - either raising or lowering
- ▶ microclimate change, exposing sheltered trees to sun or wind
- ▶ sterile soil conditions, associated with stripping off topsoil.

Construction projects within the *tree protection zone (TPZ)* of *Regulated Trees* are required to implement the protective practices described in Section 2.00.

2.10 TREE PROTECTION AND PRESERVATION PLAN

Prior to commencement of a development project, a property owner shall have prepared a *Tree Protection and Preservation Plan* if any activity is within the dripline of a *Protected* or *Designated Tree*, (see *Tree Reports, Section 6.30 and Section 1.35*). The Tree Protection Plan will be prepared by a *certified arborist* to assess impacts to trees; recommend mitigation to reduce impacts to a less than significant level and identify construction guidelines to be followed through all phases of a construction project. Projects protecting only *street trees* with fencing (see *Protective Tree Fencing, Section 2.15.D*) are exempt from preparing a Tree Protection and Preservation Plan.

Required Practices

2.15 PRE-CONSTRUCTION REQUIREMENTS

The following six steps shall be incorporated within the Tree Protection and Preservation Plan prior to building permit issuance.

A. Site Plan

On all improvement plans for the project, plot accurate trunk locations and the 'dripline areas' of all trees or groups of trees to be preserved within the development area. (see *Site Plan, Section 1.00*). In addition, for *Protected* and *Street Trees* (oaks, redwoods, heritage or *street trees*) the plans shall accurately show the trunk diameter, dripline and clearly indicate the *tree protection zone* to be enclosed with the specified tree fencing as a bold dashed line.

B. Verification of tree protection

The *project arborist* or contractor shall verify, in writing, that all preconstruction conditions have been met (tree fencing, erosion control, pruning, etc.) and is in place. Written verification must be submitted to and approved by the Planning Department prior to demolition, grading or building permit issuance (see *Inspections, Section 2.30*).

C. Pre-construction meeting

The demolition, grading and underground contractors, construction superintendent and other pertinent personnel are required to meet with the *Project Arborist* at the site prior to beginning work to review procedures, tree protection measures and to establish haul routes, staging areas, contacts, watering, etc.

D. Protective Tree Fencing for Protected Trees, Street Trees or Designated Trees

Fenced enclosures shall be erected around trees to be protected to achieve three primary goals, (1) to keep the foliage crowns and branching structure clear from contact by equipment, materials and activities; (2) to preserve roots and soil conditions in an intact and non-compacted state and; (3) to identify the *tree protection zone* (TPZ) in which no soil *disturbance* is permitted and activities are restricted, unless otherwise approved (see *Tree Protection Zone, Section 1.00 and 2.15.E*).

▶ Size and type of fence

All trees to be preserved shall be protected with five or six (5' - 6') foot high chain link fences. Fences are to be mounted on two inch diameter galvanized iron posts, driven into the ground to a depth of at least 2-feet at no more than 10-foot spacing (see *Public Works Department Detail #505, Appendix K*). This detail shall appear on grading, demolition and improvement plans.

▶ Area to be fenced.



IMAGE 2.15-1
Tree Protection Fence at the Dripline



IMAGE 2.15-2
Tree Protection Fence at the Dripline



IMAGE 2.15-3
Tree Protection within a Planter Strip



IMAGE 2.15-4
Trunk Wrap Protection

• **Type I Tree Protection**

The fences shall enclose the entire area under the **canopy dripline or TPZ** of the tree(s) to be saved throughout the life of the project, or until final improvement work within the area is required, typically near the end of the project (see *Images 2.15-1 and 2.15-2*). Parking Areas: If the fencing must be located on paving or sidewalk that will not be demolished, the posts may be supported by an appropriate grade level concrete base.

• **Type II Tree Protection**

For trees situated within a **narrow planting strip**, only the planting strip shall be enclosed with the required chain link protective fencing in order to keep the sidewalk and street open for public use.(see *Image 2.15-3*)

• **Type III Tree Protection**

Trees situated in a small tree well or **sidewalk planter pit**, shall be wrapped with 2-inches of orange plastic fencing as padding from the ground to the first branch with 2-inch thick wooden slats bound securely on the outside. During installation of the wood slats, caution shall be used to avoid damaging any bark or branches. Major scaffold limbs may also require plastic fencing as directed by the *City Arborist*. (see *Image 2.15-4*)

notes:

- ▶ Duration
Tree fencing shall be erected before demolition, grading or construction begins and remain in place until final inspection of the project permit, except for work specifically required in the approved plans in which case the *project arborist* or *City Arborist* (in the case of *streettrees*) must be consulted.
- ▶ 'Warning' Sign
A warning sign shall be prominently displayed on each fence. The sign shall be a minimum of 8.5 x 11-inches and clearly state: **WARNING - Tree Protection Zone** - This fence shall not be removed and is subject to a penalty according to PAMC Section 8.10.110.9. (see *Image 2.15-5*).



IMAGE 2.15-5
'Warning' Sign

Required Practices

E. Tree Protection Zone or (TPZ)

Each tree to be retained shall have a designated TPZ identifying the area sufficiently large enough to protect the tree and roots from *disturbance*. The recommended TPZ area can be determined by the formula outlined (see *Definitions, Tree Protection Zone, Section 1.36*). The TPZ shall be shown on all site plans (see *Definitions, Site Plan, Section 1.28*) for the project. Improvements or activities such as paving, utility and irrigation *trenching* and other ancillary activities shall occur outside the TPZ, unless authorized by the *City Arborist*, or by project approval. Unless otherwise specified, the protective fencing shall serve as the TPZ.

1. Activities prohibited within the TPZ include:

- ▶ Storage or parking vehicles, building materials, refuse, excavated spoils or dumping of poisonous materials on or around trees and roots. Poisonous materials include, but are not limited to, paint, petroleum products, concrete or stucco mix, dirty water or any other material which may be deleterious to tree health.
- ▶ The use of tree trunks as a winch support, anchorage, as a temporary power pole, sign posts or other similar function.
- ▶ Cutting of tree roots by utility *trenching*, foundation digging, placement of curbs and trenches and other miscellaneous excavation without prior approval of the *City Arborist*.
- ▶ Soil *disturbance* or grade change (see *Grade Changes and Trenching, Section 2.20*).
- ▶ Drainage changes.

2. Activities permitted or required within the TPZ include:

- ▶ Mulching. During construction, wood chips may be spread within the TPZ to a 4-to 6-inch depth, leaving the trunk clear of mulch to help inadvertent *compaction* and moisture loss from occurring. The mulch may be removed if improvements or other landscaping is required. Mulch material shall be 2-inch unpainted, untreated wood chip mulch or approved equal.
- ▶ *Root Buffer*. When areas under the tree canopy cannot be fenced, a temporary buffer is required and shall cover the root zone and remain in place at the specified thickness until final grading stage (see *Definitions, Section 1.27, and Heavy Equipment, Section 2.20 C*).
- ▶ Irrigation, aeration, fertilizing or other beneficial practices that have been specifically approved for use within the TPZ.

3. Erosion Control. If a tree is adjacent to or in the immediate proximity to a grade slope of 8% (23 degrees) or more, then approved erosion control or silt barriers shall be installed outside the TPZ to prevent siltation and/or erosion within the TPZ.

F. Tree Pruning, Surgery and Removal

Prior to construction, various trees may require that branches be pruned clear from structures, activities, building encroachment or may need to be strengthened by means of mechanical support or surgery. The most compelling reason to prune is to develop a strong, safe framework and tree structure. Such pruning, surgery or the *removal* of trees shall adhere to the following standards:

1. Pruning limitations:

- ▶ Minimum Pruning: If the *project arborist* recommends that trees be pruned, and the type of pruning is left unspecified, the standard pruning shall consist of 'crown cleaning' as defined by ISA Pruning Guidelines (see *Pruning, Section 5.15, and Appendix E*). Trees shall be pruned to reduce hazards and develop a strong, safe framework.
- ▶ Maximum Pruning: Maximum pruning should only occur in the rarest situation approved by the *City Arborist*. No more than one-fourth (25 percent) of the functioning leaf and stem area may be removed within one calendar year of any *protected* or *designated tree*, or *removal* of foliage so as to cause the unbalancing of the tree. It must be recognized that trees are individual in form and structure, and that pruning needs may not always fit strict rules. The *project arborist* shall assume all responsibility for special pruning practices that vary from the standards outlined in this *manual* (see *Excessive Pruning, Section 1.15*).
- ▶ Tree Workers. Pruning shall not be attempted by construction or contractor personnel, but shall be performed by a qualified tree care specialist or certified tree worker, according to specifications contained within this *Manual* (see *Pruning Mature Trees, Section 5.20*).

notes:

Required Practices

notes:

2. Surgery. Prior to construction, if it is necessary to promote health and prolong useful life or the structural characteristics, then trees shall be provided the appropriate treatments (e.g. cavity screening, bark tracing, wound treatment, cables, rods or pole supports) as specified by the *project arborist* (see *ANSI A-300, Appendix G*).
3. Tree *Removal Procedure*. When *Regulated Trees* are removed and adjacent trees that are to be preserved (as shown on the approved *site plans*) must be protected, then the following tree *removal practices* apply:
 - ▶ Tree Removal
Removal of trees that extend into the branches or roots of *Regulated Trees* shall not be attempted by demolition or construction personnel, grading or other heavy equipment. A *certified arborist* or tree worker shall remove the tree carefully in a manner that causes no damage above or below ground to trees that remain.
 - ▶ Stump Removal
Before performing stump extraction, the developer shall first consider whether or not roots may be entangled with trees that are to remain. If so, these stumps shall have their roots severed before extracting the stump. *Removal* shall include the grinding of stump and roots to a minimum depth of 24-inches but expose soil beneath stump to provide drainage. In sidewalk or small planter areas to be replanted with a new tree, the entire stump shall be removed and the planting pit dug to a depth of 30-inches. If dug below 30-inches, compact the backfill to prevent settling. Large surface roots three feet from the outside circumference shall be removed, including the spoils and backfilled with City approved topsoil to grade, and the area tamped to settle the soil.

Required Practices

2.20 ACTIVITIES DURING CONSTRUCTION & DEMOLITION NEAR TREES

Soil *disturbance* or other injurious and detrimental activity within the *Tree Protection Zone* (TPZ) is prohibited unless approved by the City based on a *tree report*. If an injurious event inadvertently occurs, or soil *disturbance* has been specifically conditioned for project approval, then the following mitigation is required:

A. Soil Compaction

If *compaction* of the soil occurs, it shall be mitigated as outlined in Soil Compaction Damage, Section 2.20, E and/or Soil Improvement, Section 5.50.

B. Grading Limitations within the Tree Protection Zone

- ▶ Grade changes outside of the TPZ shall not significantly alter drainage to the tree.
- ▶ Grade changes within the TPZ are not permitted.
- ▶ Grade changes under specifically approved circumstances shall not allow more than 6-inches of fill soil added or allow more than 4-inches of existing soil to be removed from natural grade unless mitigated.

- ▶ Grade fills over 6-inches or impervious overlay shall incorporate an approved permanent aeration system, permeable material or other approved mitigation.
- ▶ Grade cuts exceeding 4-inches shall incorporate retaining walls or an appropriate transition equivalent.

notes:

C. Trenching, Excavation and Equipment Use

Trenching, excavation or boring activity within the TPZ is restricted to the following activities, conditions and requirements if approved by the *City Arborist*. (See *Restriction Zones for Excavation, Trenching or Boring Near Regulated Trees, Image 2.20-1 through 2.20-3*). Mitigating measures shall include prior notification to and direct supervision by the *project arborist*.

Required Practices

1. Notification. Contractor shall notify the *project arborist* a minimum of 24 hours in advance of the activity in the TPZ.
2. Root Severance. Roots that are encountered shall be cut to sound wood and repaired (see *Root Injury, Section 2.25 A-1*). Roots 2-inches and greater must remain injury free.
3. Excavation. Any approved excavation, demolition or extraction of material shall be performed with equipment sitting outside the TPZ. Methods permitted are by hand digging, hydraulic or pneumatic air excavation technology. Avoid excavation within the TPZ during hot, dry weather.
 - ▶ If excavation or *trenching* for drainage, utilities, irrigation lines, etc., it is the duty of the contractor to tunnel under any roots 2-inches in diameter and greater.
 - ▶ Prior to excavation for foundation/footings/walls, grading or *trenching* within the TPZ, roots shall first be severed cleanly 1-foot outside the TPZ and to the depth of the future excavation. The trench must then be hand dug and roots pruned with a saw, sawzall, narrow trencher with sharp blades or other approved root pruning equipment.
4. Heavy Equipment. Use of backhoes, steel tread tractors or any heavy vehicles within the TPZ is prohibited unless approved by the *City Arborist*. If allowed, a protective *root buffer* (see *Root Buffer and Damage to Trees, Section 2.25.A-1*) is required. The protective buffer shall consist of a base course of tree chips spread over the root area to a minimum of 6-inch depth, layered by 3/4-inch quarry gravel to stabilize 3/4-inch plywood on top. This buffer within the TPZ shall be maintained throughout the entire construction process.
 - ▶ Structural design. If injurious activity or interference with roots greater than 2-inches will occur within the TPZ, plans shall specify a design of special foundation, footing, walls, concrete slab or pavement designs subject to *City Arborist* approval. Discontinuous foundations such as concrete pier and structural grade beam must maintain natural grade (not to exceed a 4-inch cut), to minimize root loss and allow the tree to use the existing soil.

notes:

IMAGE 2.20-1

Restriction Zones For Excavation, Trenching Or Boring
Within A Tree Dripline In A Planter Strip

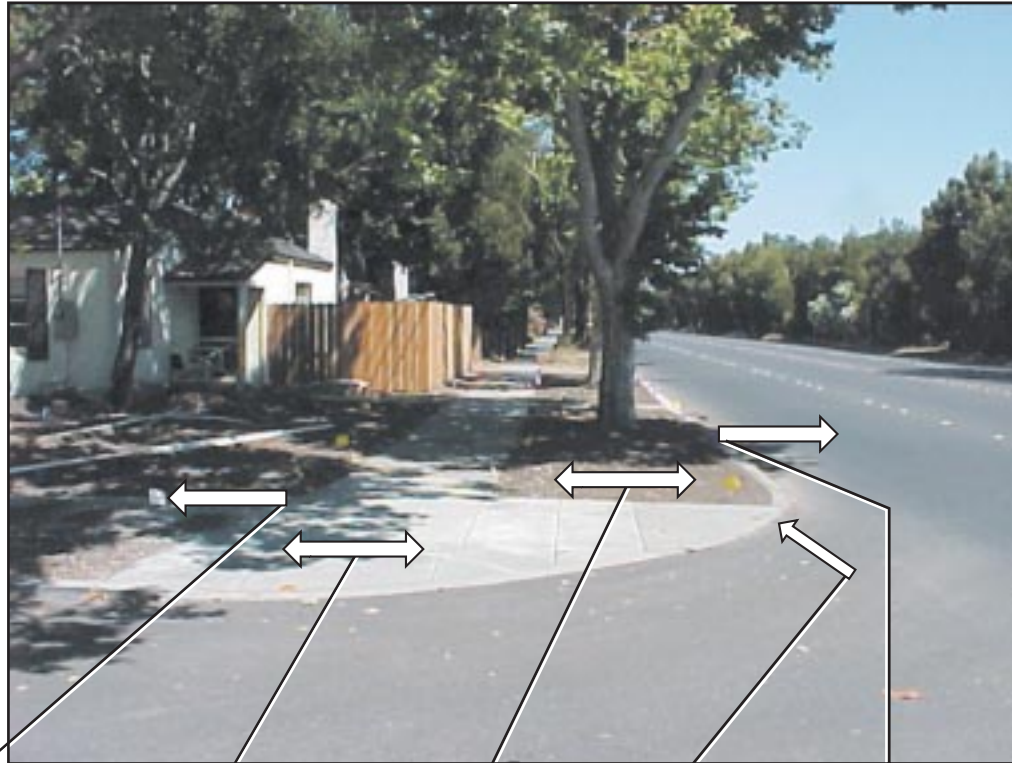

Zone 1
Private Property

Severing roots greater than 1" needs approval by property owner arborist.

Zone 2
Sidewalk

Severing roots greater than 2" needs approval by Public Works Arborist.

Zone 3
Planter Strip

No mechanical digging.
Severing roots greater than 2" needs approval by Public Works Arborist.

Zone 4
Curb & Gutter

Severing roots greater than 2" needs approval by Public Works Arborist.

Zone 5
Roadway

No Restrictions

notes:

IMAGE 2.20-2
Restriction Zones For Excavation, Trenching Or Boring
within A Tree Dripline And No Curb Or Sidewalk

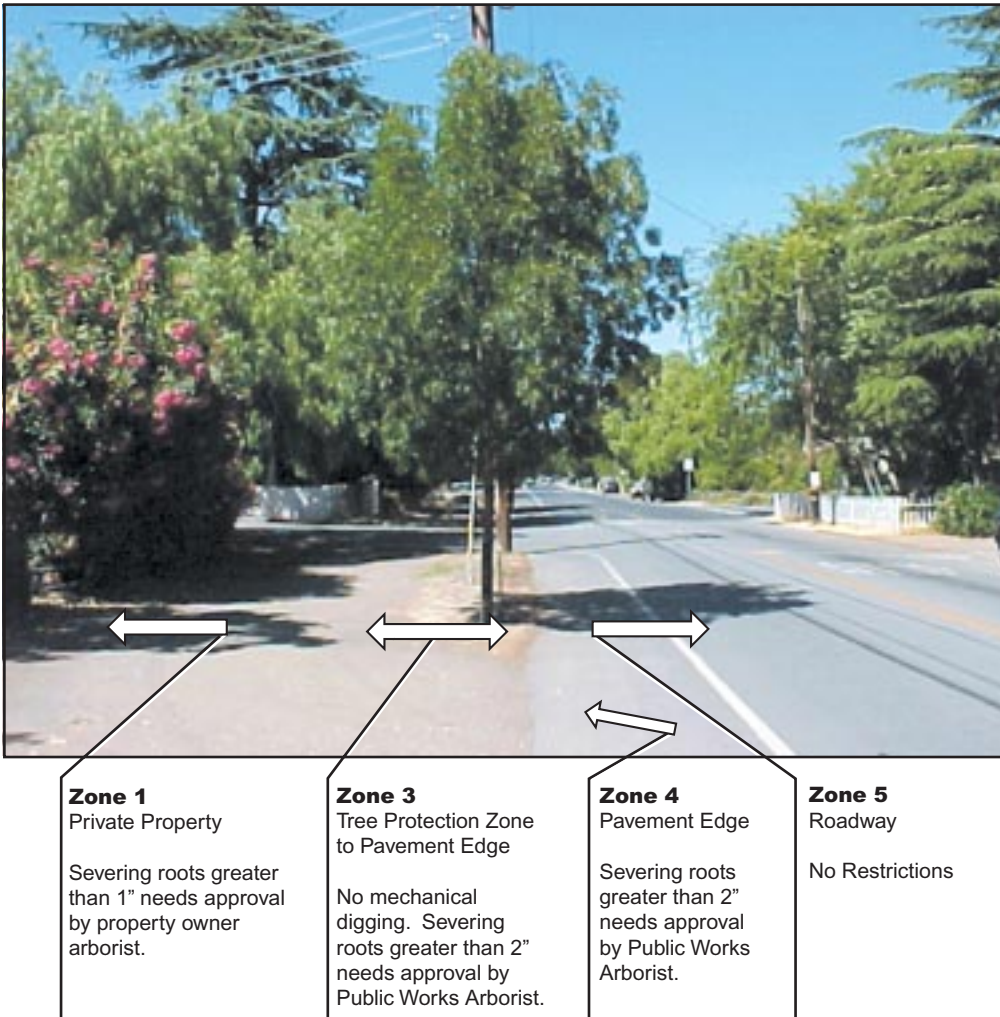

notes:

IMAGE 2.20-3

Restriction Zones for Excavation, Trenching or Boring within a Tree Dripline behind Sidewalk and Rolled Curb

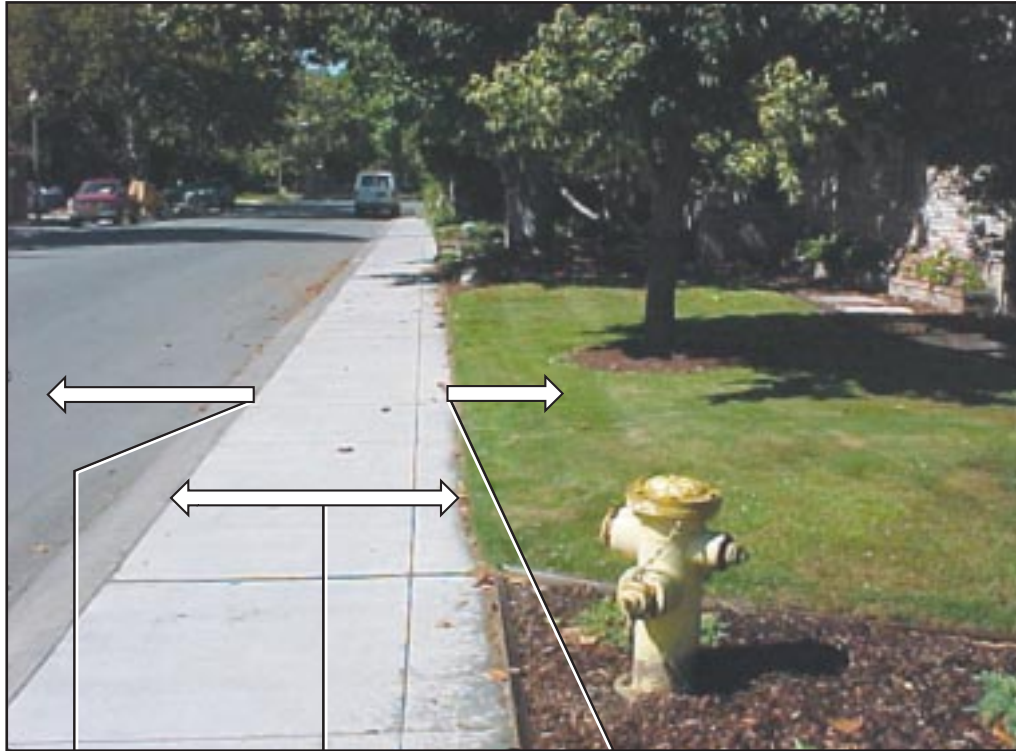

Zone 5
Roadway
No Restrictions

Zone 2
Sidewalk
Severing roots greater than 2" needs approval by Public Works Arborist.

Zone 1
City Owned Tree
City owned tree is usually within 5' back of sidewalk. Severing roots greater than 1" needs approval by Public Works Arborist.

- ▶ Basement excavations shall be designed outside the TPZ of all *protected and designated trees* (see *Excavation, Section 2.20-3*) and shall not be harmful to other mature or neighboring property trees.



notes:

D. Tunneling & Directional Drilling

If *trenching* or pipe installation has been approved within the TPZ, then the trench shall be either cut by hand, air-spade, hydraulic vac-on excavation or, by mechanically boring the tunnel under the roots with a horizontal directional drill and hydraulic or pneumatic air excavation technology. In all cases, install the utility pipe immediately, backfill with soil and soak within the same day. Installation of private utility improvements shall be tunnel bored beneath the tree and roots per *Trenching Tunneling & Distance Matrix* in Table 2-1.

Required Practices

TABLE 2-1
Trenching & Tunneling Distance

| TRENCHING DISTANCE | |
|---|---|
|  | |
| When the Tree Diameter At 4.5 Ft Is: | Trenching will be Replaced with Boring at this Minimum Distance (10x tree dia.) from the Face of the Tree in any Direction: |
| 6-9" Measured At 6" à | 6-9' |
| 10-14" Measured At 54" à | 10-14' |
| 15-19" Measured At 54" à | 15-19' |
| Over 19" Measured At 54" à | 20' + |
| DEPTH OF TUNNELING | |
|  | |
| Tree Diameter | Depth of Tunneling |
| 9" Or Less Measured At 6" à | 2.5' |
| 10-14" Measured At 54" à | 3.0' |
| 15-19" Measured At 54" à | 3.5' |
| More Than 19" Measured At 54" Depth of Tunnel | 4.0' |

Bore Pits Shall Be Located At A Minimum Distance As Specified By The Trenching Distance Table Above.

1. **Public Utilities**
Underground public utility improvements or repairs shall be performed in accordance with the *Utility Standards for Excavation, Trenching or Boring, Section 02200.309*; and per *Restriction Zones Near Regulated Trees* (see *Images 2.20-1 through 2.20-3*).
2. **Street Trees**
Exclusions for *street trees* in the publicly owned right-of-way (ROW).
 - ▶ *Street Trees* that are in conflict with utility infrastructure where the conflict cannot be resolved may be removed if approved by Public Works Operations (e.g., a tree planted directly on top of a damaged sewer lateral.)

notes:

- ▶ Emergency utility repairs shall be exempt from the above restriction zones within the TPZ. The *City Arborist* shall be contacted after any such repairs that may result in significant tree damage or *removal*.

Required Practices

E. Injury Mitigation

A mitigation program is required if the approved development will cause drought stress, dust accumulation or soil *compaction* to trees that are to be saved. To help reduce impact *injury*, one or more of the following mitigation measures shall be implemented and supervised by the project arborist as follows:

1. Irrigation Program. Irrigate to wet the soil within the TPZ to a depth of 24-inches to 30-inches. Or, apply sub-surface irrigation at regular specified intervals by injecting on approximate 3-foot centers, 10-gallons of water per inch trunk diameter within the TPZ. Duration shall be until project completion or monthly until seasonal rainfall totals at least 8-inches of rain, unless specified otherwise by the *project arborist*.
2. Dust Control Program. During periods of extended drought, wind or grading, spray wash trunk, limbs and foliage to remove accumulated construction dust.
3. Soil Compaction Damage. *Compaction* of the soil is the largest killer of trees on construction sites due to suffocation of roots and ensuing decline of tree health. If a *compaction* event to the upper 12-inch soil horizon within the tree protection zone has or will occur by any means, then one or more of the of the following mitigation measures shall be implemented (*see Compaction and Grade Change, Section 2.20 A&B and Soil Improvement, Section 5.50*).
 - ▶ Type I Mitigation. If an approved paving, hardscape or other compromising material encroaches within the TPZ, an aeration system shall be designed by the *project arborist* and used within this area (subject to approval by the *City Arborist*).
 - ▶ Type II Mitigation. If inadvertent *compaction* of the soil has occurred within the TPZ, the soil shall be loosened by one or more of the following methods to promote favorable root conditions: *vertical mulching, soil fracturing, core-venting, radial trenching* or other method approved by the *City Arborist* (*see Soil Improvement, Section 5.50*).
 - ▶ Type III Mitigation. For City-owned improvements in the right-of-way, areas within the TPZ that will be improved (e.g., asphalt, concrete or pavement) soil shall be compacted to 95% proctor density. Unimproved areas (e.g., grass, open landscape strip, etc.) soil in the TPZ shall not exceed 85% by water jet *compaction*.

Required Practices

2.25 DAMAGE TO TREES

A. Reporting

Any damage or injury to trees shall be reported within 6-hours to the *project arborist* and job superintendent or *City Arborist* so that mitigation can take place. All mechanical or chemical *injury* to branches, trunk or to

roots over 2-inches in diameter shall be reported in the *monthly inspection report*. In the event of *injury*, the following mitigation and damage control measures shall apply:

1. Root injury: If trenches are cut and tree roots 2-inches or larger are encountered they must be cleanly cut back to a sound wood lateral root. The end of the root shall be covered with either a plastic bag and secured with tape or rubber band, or be coated with latex paint. All exposed root areas within the TPZ shall be backfilled or covered within one hour. Exposed roots may be kept from drying out by temporarily covering the roots and draping layered burlap or carpeting over the upper 3-feet of trench walls. The materials must be kept wet until backfilled to reduce evaporation from the trench walls.
2. Bark or trunk wounding: Current bark tracing and treatment methods shall be performed by a qualified tree care specialist within two days.
3. Scaffold branch or leaf canopy *injury*: Remove broken or torn branches back to an appropriate branch capable of resuming terminal growth within five days. If leaves are heat scorched from equipment exhaust pipes, consult the *project arborist* within 6 hours.

B. Penalty for damage to street trees

In the event that *street trees* or their roots have been damaged, the contractor or property owner shall be subject to the penalty rate of \$100.00 per inch of damage (City of Palo Alto, Current FY Fee Schedule - subject to change). Measurement of the damage shall be the width of the wound measured across the grain at the widest point. Penalty fee shall be paid to the City and deposited to the general fund as required.

notes:

Required Practices
PAMC 8.04.070

2.30 INSPECTION SCHEDULE

The *project arborist* or Landscape Architect retained by the applicant shall conduct the following required inspections of construction sites containing *protected* and *designated trees*. Inspections shall verify that the type of tree protection and/or plantings are consistent with the standards outlined within this *Manual* and Conditions of Approval for discretionary projects. For each required inspection or meeting, a written summary of the changing tree related conditions, actions taken, and condition of trees shall be provided to the City of Palo Alto. *Monthly Inspection Reports* shall be faxed to the Planning Arborist at (650) 329-2154.

TABLE 2-2
Inspection Schedule

| INSPECTION SCHEDULE | |
|---|--|
|  | |
| A. | <u>Inspection of Protective Tree Fencing.</u> The <i>City Arborist</i> shall be in receipt of a written statement from the applicant or <i>project arborist</i> verifying that he has conducted a field inspection of the trees and that the protective tree fencing is in place prior to issuance of a demolition, grading, or building permit, unless otherwise approved (see <i>Verification of Tree Protection, Section 1.39</i>). |
| B. | <u>Pre-Construction Meeting.</u> Prior to commencement of construction, the applicant or contractor shall conduct a pre-construction meeting to discuss tree protection with the job site superintendent, grading equipment operators, <i>project arborist</i> , <i>City Arborist</i> , and, if a city maintained irrigation system exists, the Parks Manager (Contact 650-496-6962). |
| C. | <u>Inspection of Rough Grading.</u> The <i>project arborist</i> shall perform an inspection during the course of rough grading adjacent to the TPZ to ensure trees will not be injured by compaction, cut or fill, drainage and trenching, and if required, inspect aeration systems, tree wells, drains and special paving. The contractor shall provide the <i>project arborist</i> at least 48 hours advance notice of such activity. |
| D. | <u>Monthly Inspections.</u> The <i>project arborist</i> shall perform monthly inspections to monitor changing conditions and tree health. The <i>City Arborist</i> shall be in receipt of an inspection summary during the first week of each calendar month or, immediately if there are any changes to the approved plans or protection measures (see <i>Monthly Inspection Report, Section 1.17</i>). |
| E. | <u>Special activity within the Tree Protection Zone.</u> Work in this area (TPZ) requires the direct onsite supervision of the <i>project arborist</i> (see <i>Trenching, Excavation and Equipment, Section 2.20 C</i>). |
| F. | <u>Landscape Architect Inspection.</u> For <i>discretionary development projects</i> , prior to temporary or final occupancy the applicant or contractor shall call for the Landscape Architect to perform an on site inspection of all plant stock, quality of the materials and planting (see <i>Quality, Section 5.20.1 A</i>) and that the irrigation is functioning consistent with the approved construction plans. The City shall be in receipt of written verification of Landscape Architect approval prior to scheduling the final inspection, unless otherwise approved. |

2.40 PAVEMENT AND HARDSCAPE CONFLICTS WITH TREE ROOTS

Conflicts may occur when tree roots grow adjacent to paving, foundations, sidewalks or curbs (hardscape). Improper or careless extraction of these elements can cause severe *injury* to the roots and instability or even death of the trees. The following alternatives must first be considered before root pruning within the TPZ of a *Regulated Tree*.

A. Removal and Replacement of Pavement or Sidewalk:

- ▶ Removal of existing pavement over tree roots shall include the following precautions: Break hardscape into manageable pieces with a jackhammer or pick and hand load the pieces onto a loader. The loader must remain on undisturbed pavement or off exposed roots. Do not remove base rock that has been exploited by established absorbing roots. Apply untreated wood chips over the exposed area within one hour, then wet the chips and base rock and keep moist until overlay surface is applied.
- ▶ Replacement of pavement or sidewalk: An alternative to the severance of roots greater than 2- inches in diameter should be considered before cutting roots. If an alternative is not feasible remove the sidewalk, grind roots only as approved by the Public Works Arborist and replace sidewalk using #3 dowels at the expansion joint if within 10-feet of a street tree. Use a wire mesh reinforcement within if within 10-feet of the trunk of a *protected* or *street tree*.

Note: Any work in the right-of-way requires a street work permit from Public Works Department.

B. Alternative methods to prevent root cutting:

The following remedies should be considered before cutting tree roots that may result in tree instability or decline:

- ▶ Grinding a raised sidewalk edge.
- ▶ Ramping the walking surface over the roots or lifted slab with pliable paving.
- ▶ Routing the sidewalk around the tree roots.
- ▶ Install flexible paving or rubberized sections.
- ▶ On private property, new sidewalk or driveway design should consider alternatives to conventional pavement and sidewalk materials. Substitute permeable materials for typical asphalt or concrete overlay, sub-base or footings to consider are: permeable paving materials (such as ECO-Stone or RIMA pavers), interlocking pavers, flexible paving, wooden walkways, porches elevated on posts and brick or flagstone walkways on sand foundations.

C. Avoiding Conflict

Conflicts and associated costs can be avoided or reduced by the following planting practices:

- ▶ Plant deep rooted trees that are proven to be non-invasive.
- ▶ Over soil that shrinks and swells, install a sidewalk with higher strength that has wire mesh and/or expansion slip joint dowel reinforcement.
- ▶ Follow soil loosening planting techniques to promote deep rooting.

notes:

Required Practices

Recommended Practices

Recommended Practices

notes:

- ▶ Install root barrier only along the hardscape area of the tree (but allow roots to use open lawn or planter strip areas).
- ▶ Dedicate at least 10-linear feet of planting space for the growth of each tree.

Recommended
Practices

D. Alternative Base Course Materials

When designing hardscape areas near trees, the project architect or engineer should consider the use of recommended base course material such as an engineered structural soil mix. The Palo Alto approved structural soil mix will allow a long term cost effective tree and infrastructure compatibility that is particularly suited for the following types development projects: repair or replacement of sidewalk greater than 40-feet in length; subdivisions with new street tree plantings; planting areas that are designed over structures or parking garages; confined parking lot medians and islands or other specialized conditions as warranted. (see *City of Palo Alto Public Works Improvement Specifications Standards and; www.amereq.com/cuintro*).



END OF SECTION

CITY OF PALO ALTO
TREE TECHNICAL MANUAL
STANDARDS AND SPECIFICATIONS

notes:

SECTION 3.00 - REMOVAL, REPLACEMENT AND PLANTING OF TREES

INTRODUCTION

A *Regulated Tree* may not be removed without City review and approval, except in certain emergencies. The purpose of City review is to verify that the removal is allowed under City law, and to prevent unnecessary tree removal. In some cases, a removed tree must be replaced by the property owner or, in the case of street trees, developer. This section describes the type and size of tree required, and the planting techniques to be used. It also describes how to determine the replacement value of a tree that cannot be replaced in its original location, and the circumstances in which the City may require a security deposit to assure the survival of trees during development projects.

3.05 TREE REMOVAL

A. Allowable Removal

A written permit is required to remove a *Regulated Tree*, except in emergency situations outlined in Hazardous Trees, Section 4.00. *Removal of Regulated Trees* is allowed if:

- ▶ A *Protected Tree* is determined to be dead, hazardous (see *Hazardous trees, Section 4.0*), a detriment to or crowding an adjacent *protected tree*, or a *Public Nuisance* (see *Section 1.00*).
- ▶ A *protected tree* trunk is touching or the basal flare is under the building footprint of an existing building (for example, uplifting foundation, contact or damage to eaves, gutter, etc.).
- ▶ On projects other than a single family residence, a *Protected Tree* if it reduces the otherwise-permissible *Buildable Area* by more than 25%.
- ▶ Other specific circumstances exist, as described in Section 8.10.050, Appendix A.
- ▶ In the case of *street trees*, Public Works Operations issues a written approval.
- ▶ In the case of a *Designated Tree* shown on previously approved site or landscape plans, the Director approves the removal in writing.

B. Permit Application

Tree Removal Applications are available at the City of Palo Alto, Development Center, 285 Hamilton Avenue, Palo Alto, CA 94301, 650-617-3118. The following is a checklist of items necessary for City review for tree removal. Additional information may be required by the reviewing staff. Response will generally be mailed to the applicant within 10 days. The removal permit must be on site during the *removal*.

Required Practices

notes:

Tree Removal Checklist

- Completed City of Palo Alto Protected Tree Removal Application (available at the City of Palo Alto, Development Center, 285 Hamilton Avenue, Palo Alto, CA 94301. (650) 617-3118).
- Payment of \$145.00 review process fee (\$125 Schedule Fee and \$20 Records Management)
- Arborist letter report from a *certified arborist* on company letterhead (see *Tips for Selecting an Arborist, Section 5.95, and Tree Reports, Section 6.10*) — to include the following information for each tree:
- A written narrative describing the tree species (common and scientific); location (in relation to street, structures and property line); size (DBH, height & crown spread); condition (foliage, vigor, structural integrity, etc.); life expectancy and prognosis (is the tree *hazardous*, severe decline, property damage, etc.?)

C. Hazard Trees

To remove a *protected* or *designated* tree that has been verified as *hazardous*, as defined within Chapter 8.10 of the Palo Alto Municipal Code and *Tree Technical Manual*, written approval from the *City Arborist* is required and must be available on site when the tree is being removed, unless emergency conditions exist (see *Emergency Removal Conditions, Section 4.00*).

3.10 WHEN TREE REPLACEMENT IS REQUIRED

Replacement Trees. Certain conditions determine whether or not a *protected* or *designated tree* must be replaced. In summary, they are:

A. Protected Trees

If the City authorizes removal of a protected tree because it is dead, dangerous, or a nuisance, no tree replacement is required. In all other cases, the tree must be replaced.

B. Designated Trees

When authorizing removal of a *Designated Tree*, the Director or the Director's designee shall require tree replacement if it is necessary or desirable to implement the intent of the original site design. The number and nature of the replacement trees shall be determined by the Director or designee, taking into consideration the value of the tree removed and the site design.

C. Street Trees

If the City authorizes removal of a street tree in connection with a development project, it shall specify the replacement requirements in the permit authorizing removal.

Required Practices

PAMC 8.10.050

PAMC 8.04.070

3.15 ALTERNATIVES WHEN TREES CANNOT BE REPLACED ON SITE

In some circumstances, crowding or other physical constraints make it impossible or undesirable to replace a tree of equal value in the same place. In that case, the value of the tree shall be computed under the Tree Value Replacement Standard in Section 3.25. Once the value has been determined, that sum of money shall be used in the following order of preference, as approved by the Director: (1) to provide additional trees elsewhere on the site; (2) to add or replace street trees or other public landscaping in the vicinity, or (3) to add trees or other landscaping to other City property.

3.20 TREE CANOPY REPLACEMENT STANDARD FOR ONSITE TREE REPLACEMENT

When a *Protected* or *Designated Tree* is to be replaced on site, the following standards apply.

A. Species

The replacement trees shall be the same species unless the Director determines that another species would be more suitable for the location. Factors to be considered include the long term health of the tree in the location and its compatibility with the adjacent uses as well as design considerations.

B. Location

The location of the replacement tree on site shall be approved by the Director. If it is not possible or desirable to replace the tree on site, Section 3.15 shall apply.

notes:

Required Practices

notes:

C. Size and Number

Often it is not possible to replace a large, older tree with a single equivalent tree. In such cases, the following tree canopy replacement ratio shall be used:

TABLE 3-1

Tree Canopy - Replacement Standard

| COLUMN 1 | COLUMN 2 | COLUMN 3 |
|---|--|-----------------------------------|
| Canopy of the Removed Tree (Avg. dist. across the canopy*) | Replacement Trees | Alternative Tree |
| 4'-9' | Two 24" Box Size (minimum) | One 36" Box Size |
| 10'-27' | Three 24" Box Size | Two 36" Box Size |
| 28'-40' | Four 24" Box Size | Two 48" Box Size |
| 40'-56' | Six 24" Box Size | Two 48" Box & Two 36" Box Size |
| 56'-60' | Two 24" Box & Two 36" Box + Two 48" Box Size | ** |
| 60'+ | ** | ** |

*Add half of the difference between the two to the narrowest measurement for the average canopy.

** Replace the tree with a combination of both Tree Canopy and Tree Value Standards.

Note: Basis of this table is determined by the growth of one 24" box size tree, growing at a rate equivalent to 9 feet of canopy over the course of ten years.

How to use Table 3-1, Tree Canopy Replacement Table.

- ▶ Column 1. Determine the leaf canopy of the removed tree by measuring the distance across the canopy at the widest point and narrowest point. Add half of the difference between the two to the narrowest measurement for the average canopy. The leaf canopy diameter of the tree (this information is typically supplied within the arborist report) is used to determine number and size of replacement trees in Column 2.
- ▶ Column 2. Determine the number of replacement trees. The planting of new trees should equal the leaf canopy of the removed tree within a period of ten years. The minimum replacement for removal of any *Protected or Designated Tree* shall be two 24-inch box trees.
- ▶ Column 3. Alternative size of trees may be desired. The property owner shall have the option to plant an alternative size tree to accommodate site specific landscape needs or constraints, such as space, design or soil volume limitations.

Example of Tree Canopy Replacement Ratio:

The removal of a tree with a 39' crown spread will require four 24-inch box trees to satisfy the criteria of this Section. Methodology- e.g. the average canopy of a new tree is 4' wide + the expected canopy growth of 6" per year x 10 years = a 9' net canopy of one replacement tree. Thus, four 9' trees = 36' of new canopy, and is a close approximate to the original 39' canopy tree.

3.25 TREE VALUE REPLACEMENT STANDARD

When the value of a tree needs to be determined for establishing the amount of security required, or for any other purpose, the value shall be determined by using the most recent edition of the *Guide for Plant Appraisal* published by the Council of Tree and Landscape Appraisers (see *Section 6.45.*)

3.26 SECURITY DEPOSITS

As a condition of a development approval, the Director may require that the developer post security of between 25% and 100% of the value of the trees to be preserved, as determined under Section 3.25. The security may be a cash deposit, letter of credit, or surety bond and shall be filed with the Finance Department. It shall be in a form satisfactory to the City Attorney. The security shall be posted before issuance of any grading or building permits. The guarantee period shall be specified; in general, it shall be at least two years after expected completion of construction. If the trees fail to survive, the developer shall replace them; if the developer fails to do so, the City may use the security to provide off site trees and/or landscaping as described in Section 3.15.

3.30 TREE AND SHRUB PLANTING SPECIFICATIONS

Planting specifications apply for trees and shrubs that are: 1) planted as a replacement for a *Regulated Tree*, 2) to be planted as a *street tree* within the City right-of-way or other public land; or 3) planted as part of a landscape plan subject to non-residential development approval (see *Discretionary Development Approval, Section 1.11*). Using the following specifications will result in consistent city-wide plantings, and superior tree growth and vitality. To achieve this, the landscape architect shall incorporate these items into their specifications.

3.35 PLANTING STOCK AND MATERIALS

A. Quality

It is the contractor's responsibility to supply stock that meets ANSI 760.1-1996 and City of Palo Alto *Tree Technical Manual Standards*.

- ▶ All plants and trees installed within the City of Palo Alto shall conform with American Association of Standards, ANSI Z60.1, *Specifications for Acceptance of Nursery Trees at the Time of Delivery*, in all ways.
- ▶ Plants shall be sound, healthy, vigorous, and free of plant disease and insect pests and their eggs.
- ▶ Container stock shall be grown for at least 8-months in containers in which delivered and shall not be root bound or have girdling roots.
- ▶ Trees shall not have been topped or headed.
- ▶ Landscape Architect shall inspect and verify, in writing, that all plant material to be installed on the site meets the above standards and is acceptable.
 - The written verification shall be forwarded to the City Planning Department files within one week of acceptance (see *Inspections, Section 2.30 F*).
 - Inspection shall occur after delivery of stock to the project site.

notes:

Required Practices

Required Practices

notes:

- ▶ Plants and trees with broken tops, branches or injured trunks shall be rejected.

Required Practices

B. Miscellaneous Materials

The following materials shall be used unless otherwise specified:

- ▶ Tree stakes. Support stakes shall be treated 2-inch diameter Lodgepole Pine, two stakes per tree or approved equivalent. No cross brace shall be used. After installation, stakes shall be trimmed so that the branches clear the top of the stake.
- ▶ Tree Ties. 'V.I.T' Tree Supports (recommended) or equivalent, twist brace, fabric-reinforced rubber (3/8-inch minimum), or equivalent approved by the City of Palo Alto shall be used and installed in a figure eight fashion to support the tree to the stakes.
- ▶ Mulch. Screened untreated wood chips 1/2- to 1-inch in size, spread to a 2-inch depth out to the edge of the root ball. The mulch should be kept at least two inches away from the trunk and shall be applied to each tree (*see Mulching, Section 3.45-G*).
- ▶ Root Control Barriers. Use along all public sidewalks, and indicate on approved plans and drawings. 18-inch Linear Barrier LB18-2 root control barrier shall be used. Unless specified otherwise, a 10-foot length shall be placed on center with the tree and on the sidewalk side only. Root barrier boxes are not approved.
- ▶ Mower guards. For trees in turf areas requiring regular mowing, the tree stem shall be protected with TreeGuard or equivalent.
- ▶ Tree Grates. Where sidewalk width is less than 8-feet and new trees will be installed in a tree well, metal tree grates shall be used and approved by Public Works. Minimum size grates shall be 4' x 4' unless specified otherwise. All tree grates shall be mounted in frames, frames inset into a concrete foundation within the sidewalk or surface material and shall be flush with the surrounding surface.

3.40 PLANTING SITE PREPARATION

Required Practices

A. Soil Preparation and Conditioning

- ▶ All debris, wood chips, pavement, concrete and rocks over 2-inches in diameter shall be removed from the planting pit to a minimum of 24-inch depth, unless specified otherwise (*see also Soil Improvement, Section 5.50*).

Required Practices

B. Planter Pit

- ▶ Trees in a confined planter pit or sidewalk area: The planting hole shall be excavated to a minimum of 30-inches deep x the width of the exposed area. Scarify the sides of the pit (*see Placing the Tree, Section 3.45 D*). Soil beneath the rootball shall be compacted to prevent settling.

- ▶ Trees in all other areas: Excavate the hole's width a minimum of three times the diameter of the container, and deep enough to allow the root ball of the container to rest on firm soil. Scarify the sides and the bottom of the pit.
- ▶ The height of the container root ball should be 1-2-inches higher than grade level (see *Placing the Tree*, 3.50), except when structural urban tree soil mix is used (see *Alternative Base Course Materials*, Section 2.40 D), in which case the tree may be planted at level grade.

notes:

C. Drainage

1. Poor drainage. For *discretionary development projects*, a percolation test is required to ensure there is adequate drainage for planting new trees. A minimum of one test per site shall be reviewed with the *project arborist* or Landscape Architect prior to plant installation. One or more of the following mitigations are required for locations with poor drainage.
2. Mitigation for locations with poor drainage:
 - ▶ Install french drain. The trench shall radiate away from the tree and be a minimum of 18-inches in depth filled with drain rock. The grade shall fall away from the tree trunk.
 - ▶ Install drain tiles or perforated pipe directing water away from the tree.
 - ▶ Install a drain chimney at the bottom of the planting pit, a minimum of 4-inches in diameter and filled with medium sand or fine gravel to ensure percolation of all water from the filled planter pit. Auger bore drain holes to penetrate hard pan or cilleechee clay a minimum of 12-inches into undisturbed pervious soil. Angle the boring as close to vertical as possible.
3. Planting Percolation Test. A minimum of one test per development site is required. Additional tests may be needed as required by Landscape Architect or *City Arborist*. Fill planting hole with water, provide drainage that is greater than 2-inches per hour. If percolation is less, one or more of the following mitigation measures must be implemented for tree planting (see *Soil Improvement*, Section 5.50).

Required Practices

Required Practices

Required Practices

D. Aeration tubes for trees

- ▶ *Street trees* planted in the City right-of-way, sidewalk planter pits, planting strip, medians or *designated trees* when specifically required in development plans, shall use 4-inch diameter perforated aeration piping (rigid or flexible), circling the bottom of the planter connected to a 'T' fitting to two riser tubes with grated caps and wrapped with filter fabric, per Public Works Planting Detail #503 for tree wells or #504 for planter strip planting (see *Appendix H*). This detail shall be shown on the approved landscape plans.
- ▶ All other trees (see *Aeration Tube Table*, 3-2) shall be planted with 4-inch diameter perforated aeration tubes with grated plastic caps placed at the edge of the root ball to the bottom of the pit per Table 3-2, Aeration Tubes. Irrigation heads shall not be installed inside the aeration pipes.

Required Practices

notes:

- ▶ Any of the above holes, pipes, grates or fixtures shall include the installation of Filter Fabric wrap over the side openings and secured as recommended by manufacturer when connected to an approved aeration system.

TABLE 3-2
Aeration Tubes

| AERATION TUBE TABLE | |
|-------------------------|-------------------------|
| TREE SIZE | NUMBER OF TUBES |
| 15 gallon trees | one tube |
| 24' box trees | two tubes |
| 36' box trees | two tubes |
| 48' box trees or larger | four tubes or as needed |

3.45 PLANTING THE TREE

A. Perform percolation test

If the soil is dry, add a few inches of water in the hole. Let it drain before planting the tree (see *Percolation Test*, Section 3.40 C).

B. Depth

To check the proper depth of the rootball, place the tree in the hole and lay a pole or shovel across the original grade - the top of the root ball should be 1 to 2-inches higher (see *notes on depth*, Section 3.40 B).

C. Container and Roots

Remove tree from the container and trim the root ball in the following way:

- ▶ Thick circling roots: straighten and/or cut cleanly
- ▶ Thin roots: make three to four vertical cuts 1/2-inch deep around root ball, spread the bottom out if necessary

D. Placing the Tree

Locate the tree in the hole, and rotate the tree to direct the main branches away from the street side, if possible.

E. Filling the Hole

Place the aeration tubes, fill the hole halfway up with original soil (amended soil only when approved), and gently tamp out air pockets with a pole or shovel handle. Add about 1-inch of water, and let drain. Fill the rest of the hole to grade, water the fill soil, and let drain.

F. Staking

Place the stakes at the edge of the root ball (drive them 2-feet into undisturbed ground), and avoid contact with the branches. If in a windy area, set the stakes in a plane at right angles to the wind. Remove the nursery stake. Loosely place two ties in a figure eight around the trunk, as low as needed to hold the tree upright and nail to the stake. Stakes shall be trimmed so that the branches clear the top of the stake. Do not install a cross-brace.

Required Practices

G. Berm, Mulch and Water

In non-turf areas, form a soil berm 3 to 4-inches high at the outermost edge of the root ball. Place 1 to 2-inches of mulch or bark over root ball and berm, keeping the mulch away from the trunk a minimum of 2-inches. Fill the berm with water to capacity (see *Watering 5.45, Section A*).

3.50 PLANTING IN DIFFICULT SOIL CONDITIONS

A. Turf Areas

In turf areas that receive regular watering, the watering berm may be eliminated. The turf shall be maintained a minimum of one foot from the new tree stem, and mulch placed on top of the rootball. The mulch shall not be touching the tree stem. In turf areas, install tree guard (see *Mower Guards, Section 3.35 B*).

B. Alternate Specifications

Occasionally, tree planting must occur in poor or difficult soil where standard planting techniques will result in poor-to-average performance or mortality (such as unique or unusual regional geology, slope, soil volume, restrictive physical or chemical properties, poor drainage, etc.). In this case, the responsible party must investigate alternative solutions to enable long term tree growth. Alternative planting specifications or plans that vary from the native or typical soil conditions shall be submitted to the *City Arborist* for approval prior to installation.

- ▶ Alternative or specified soils, such as engineered, amended or structural urban tree soil mix, including written specifications and physical samples, shall be submitted for approval from the *City Arborist* and/or *Landscape Architect* (see *Alternative Base Course Materials, Section 2.40 D*).



END OF SECTION

notes:

Recommended Practices

THIS PAGE INTENTIONALLY LEFT BLANK

CITY OF PALO ALTO
TREE TECHNICAL MANUAL
STANDARDS AND SPECIFICATIONS

notes:

SECTION 4.00 HAZARDOUS TREES

INTRODUCTION

Property owners are responsible for the trees on their own property. The City does not require advance permission for removal of Protected or Designated Trees in emergencies. However, it does require documentation of the problem after the fact. This is to avoid the unlawful removal of sound trees on the grounds that they are hazardous. If there is no immediate danger, and the structural deficiency can be corrected, it should be. If the City determines that there was no reasonable basis for believing there was an emergency, the property owner may face penalties for violating City law.

The health and safety of a tree are two distinct and separate functional characteristics. A vigorous and healthy tree may not necessarily be of sound wood or structure. To remove a dangerous *protected or designated tree*, it must first be evaluated and the tree determined to be “*hazardous*” as defined in this section. This must be verified in writing by the *City Arborist* before the tree can be removed. (see also *Removal, Replacement and Planting Trees, Section 3.00, and ISA Hazard Evaluation Form, Section 4.20 B*).

A. Tree Hazard Responsibility

On private property, it is the responsibility of the property owner to mitigate or abate a known hazardous condition of a *protected or designated tree* that may be of questionable structure or deemed as hazardous. Most tree hazards can be prevented with regular checkups by a tree care professional and timely maintenance action by the property owner. Street trees on city property that may be a public safety hazard should be reported to the City of Palo Alto, Public Works — Operations at (650) 496-5953.

B. Recognizing Tree Hazards

Determining whether or not a tree’s defects constitutes a condition that presents an imminent hazard to an area requires a high degree of knowledge and experience. Hazard tree assessment of a *protected or designated tree* should only be evaluated by an arborist who is familiar with tree physiology and can interpret the external signs of weaknesses, who can perform internal checks if necessary and recommend mitigation (see *Hazard Reduction and Prevention, Section 4.40, and Hazard Evaluation Form, Section 4.20 B*).

Required Practices

4.10 EMERGENCY REMOVAL CONDITIONS

A. Abatement

When a tree has partially failed or it is apparent it is about to fail and persons or property are threatened the tree may be removed without City review or approval. The City does not require an arborist report before the removal in this instance.

notes:

B. Authorization

Such cases must be substantiated after the fact by the property owner and tree professional with photographs, abatement information, insurance claim or other relevant information and completion of a Protected Tree Removal Application. The information is to be submitted to the City Planning Division Arborist within five days of emergency *removal*. All other authorizations are subject to the standard procedure outlined in *Removal of Protected Trees, Section 3.05*.

Required Practices

4.20 CRITERIA USED BY THE CITY TO DETERMINE IF A TREE IS HAZARDOUS

A. Definition of Hazardous

Palo Alto Municipal Code Chapter 8.10.020 defines 'Hazardous' as: an imminent hazard or threat to the safety of persons or property. If a tree possesses a structural defect that may cause the tree or part of the tree to fall on someone or something of value (i.e. 'target'), and the condition is determined to be imminent, the tree is considered *hazardous*.

B. Evaluation Form

The City uses the national standard, an ISA - HAZARD EVALUATION FORM (see Appendix C) as a basis to determine the hazard rating of a tree (see Hazard Rating, Section 4.25). This form, or an approved equivalent, must be completed by a *certified arborist*. The *City Arborist* retains discretionary right to approve, request in writing a second opinion of a rating, in writing, or recommend action that may reduce the condition to a less-than significant level of hazard.

C. Authorization

If the *hazardous* condition or *target* cannot be mitigated or reduced to a less than significant level (see Hazard Reduction and Prevention, Section 4.40) then the tree shall be authorized by the City and removed by the property owner to abate the condition.

Required Practices

4.25 DETERMINING A TREE'S HAZARD RATING

For the purpose of removal, if a tree is declared a hazard it must be rated for the level of hazard to persons or property by using the Hazard Rating Formula, or other professional methodology acceptable to the City of Palo Alto (see Hazard rating formula Table 4-1 and Appendix C):

TABLE 4-1
Hazard Rating Formula

| ISA - HAZARD RATING FORMULA International Society of Arboriculture | | | |
|--|-------------------------------------|--|--------------------------------------|
| Failure Potential | + Target | + Additional Factors/Size of Part | = Hazard Rating |
| | + | + | = |
| 1 = low 4 = severe | 1 = low 4 = severe | 1 = low 4 = severe | 3 = low 12 = severe |

Note: The above factors are combined to quantify a hazard rating. For example, a minimum rating of 3 is the safest (a low predicable hazard), and the maximum rating of 12 is an imminent hazard (a high predictable hazard). Further details regarding this formula can be found in the ISA- HAZARD EVALUATION FORM (see Appendix C) and the ISA publication * Evaluation of Hazard Trees in Urban Areas, most current edition.

A. Failure Potential Rating

Failures do not occur at random, but are the result of a combination of defects and aggravating conditions. The scope of the professional evaluation will include structural defects in the tree (including branches, trunk and roots; and if necessary, shall employ the use of the most current methods of internal decay inspection available); soil/slope and/or creek bank stability; individual species susceptibility to failure; pruning; history; decay weaknesses and any other compromising or pertinent factors considered by the consultant.

B. Target Rating

Evaluation of potential targets shall include people, structures or property use and occupancy that are imminently threatened. Property use shall consider what structures or activities are under or around the tree (e.g. building, parking, pedestrian, recreational, utility lines, hardscape, etc.). Occupancy shall consider frequency of the use (occasional, intermittent, frequent or constant), and whether the *target* will be present when failure occurs.

- ▶ Consideration shall be given as to whether the *target* can be reasonably removed or isolated to reduce the hazard rating to a less than significant level. A target means people or property (public or private).
- ▶ A tree may be a potential hazard if it is: (a) a tree with the potential to fail; (b) in an environment that increases the likelihood of failure and; (c) a tree that would strike a *target*.

C. Additional Factors

Evaluation of other factors that contribute to aggravating conditions shall be considered, such as: size of the affected defect (i.e. a small branch vs. the entire tree uprooting); significant potential of fire, utility line contact or catastrophic effects, etc.

4.30 TREE EVALUATION CHECKLIST

This part is intended to further help the property owner understand tree defects and how they may be interpreted by an arborist. Many tree defects are not readily apparent because decay or structural damage may be internal. Also, poor tree health may not reflect poor tree structure. *Hazardous* trees must be carefully evaluated. The following checklist of criteria that is typically used by professionals may indicate potential or current tree hazards. The checklist is not meant to be a comprehensive guide, however, it is an outline of indicators that may alert a property owner to potential hazards and suggest action to avert a tree failure and liability. If you answer 'yes' to one or more of the checklist items, you should contact an arborist to discuss how to reduce the potential hazard.

A. Hazard Evaluation Questionnaire

- ▶ Target: If the tree or branch falls will it hit cars, houses, structures, power lines or people? If so, immediate action may be necessary.
- ▶ Dead Branches: Are there dead tops or branches? Is the tree dead?
- ▶ Cracks: Are there deep, open cracks in the trunk or branches? These are major starting points for trunk and branch failure.

Recommended Practices

notes:

- ▶ Crotch Cracks: Are there deep, open cracks below joining trunks or stems?
- ▶ Tree Architecture: Has the tree grown beyond its species specific shape into a hazardous form? Is the tree leaning?
- ▶ History: Has the tree recently lost large branches?
- ▶ Edge Tree: Were neighboring trees recently removed, leaving tall trees exposed at the edge that may be subject to unexpected wind dynamics and blow-over?
- ▶ Living Branches: Do live branches bend abruptly upward or downward where tips of large branches were cut off? These may pull out of trunks that are weakened by rot or cracks. Beware of large branches on rotten or cracked trunks.
- ▶ *Topping*: Are large branches growing rapidly from topping cuts? These sprouts have weak attachments and may weaken further as they grow. Is there decay below topping cuts?
- ▶ Storm *injury*: Are there broken branches, split trunks, or injured roots? Are branches close to power lines?
- ▶ Root Rot: Are there fungus fruit bodies (mushrooms) on roots or near the trunk? Were roots injured by construction?
- ▶ Rots and Cankers: Are there hollows or cankers (dead spots) in the trunk or major branches, some with fungus fruit bodies?
- ▶ Construction *injury*: Have roots, trunk, or branches been injured?
- ▶ Is there a new lawn or garden over injured roots? The added fertilizer may stimulate the growth of fungi that will rot the supporting roots while the top gets heavier. A moderate storm could cause the tree to fall.
- ▶ Guying of trees. Staking and guying of small to medium size trees may benefit from the additional support. Discretion must be exercised that the guying does not hide weaknesses, such as toppling over, that result from poor quality nursery stock or girdling roots.

4.40 HAZARD REDUCTION AND PREVENTION

Review the following list to reduce hazardous conditions.

- ▶ Plant trees that are not problematic and that fit the site
The International Society of Arboriculture (ISA) has developed a list to assist you to avoid planting a tree that may become a problem (*see Inherent Failure Patterns for Selected Species, Appendix D*).
- ▶ A healthy, vigorous tree that receives regular care is less likely to become *hazardous* than one that is ignored. Prevention is the best solution to the tree hazard problem.
- ▶ The risk of a hazard tree may be reduced by removing dead and broken branches, reducing branch end weights, by mechanically supporting weak branches from below, or by cabling and bracing.

Recommended
Practices

In some cases, *targets* may be removed such as by moving picnic tables or other items beneath a precarious tree, fencing to prevent access to such trees, or rerouting pedestrian or vehicular traffic.

- ▶ If there are no other options to abate the hazard, the tree may need to be removed entirely (see *Removing a Hazardous Tree, Section 4.10*). Steps outlined in the Tree Removal Procedure (see *Section 3.05*) should be submitted as soon as possible for review by the City.

The following checklist will help property owners avoid future problems:

- Inspect your trees carefully at least once each season every year. Annually, have a *Certified Arborist* inspect your trees and provide you with a written report.
- Avoid planting brittle species where falling limbs could injure people or property (see *Inherent Failure Patterns for Selected Species, Appendix D*).
- Prune trees when they are young (see *Pruning Young Trees, Section 5.30*) and regularly thereafter.
- Use correct pruning methods, always making the pruning cut outside the branch collar. This will allow only the minimum of decay infection.
- Do not allow *topping* (see *Definition, Section 1.32*).
- Always plant the right tree in the right place. Select trees based upon their mature height and shape, and make sure the species selected matches the soil and other site characteristics. For example, avoid planting tall-growing trees such as redwoods near power lines or too close to your house (see *Inherent Failure Patterns for Selected Species, Appendix D*).
- Water thoroughly (generally, until saturation is reached) during dry periods, slowly applying at least 2-inches of water per week (see *Watering, Section 5.45*).
- Erect barriers around or slightly beyond the root protection zone of trees during construction. Insist that these root protection zones be honored by construction workers.
- Consider cabling or bracing weak forks of branches in larger trees of high value.
- Do not plant trees with a narrowly-forked stem v-crotch, imbedded bark or girdling root ball.
- Where a valuable specimen tree may be suspected of developing into a *hazardous* tree, use landscaping to keep people at a safe distance. This may require techniques such as rerouting walks, moving patio furniture, or planting shrubs and hedges to function as barriers to keep foot traffic at a safe distance (see *Determining if a Tree is Hazardous, Section 4.20*).



END OF SECTION

THIS PAGE INTENTIONALLY LEFT BLANK

CITY OF PALO ALTO
TREE TECHNICAL MANUAL
STANDARDS AND SPECIFICATIONS

notes:

SECTION 5.00 TREE MAINTENANCE GUIDELINES

INTRODUCTION

This chapter establishes the minimum standard of care and maintenance of Palo Alto's *Regulated Trees*. These standards apply to all persons who own or are engaged in the business of repairing, maintaining, or preserving these trees. The following standards of care are set forth for pruning (including utility, fire and traffic encroachment), planting, watering, soil and nutrient requirements, insect, disease and fruit control. Guidelines for selecting an arborist are also given. These standards and guidelines are based on sound arboricultural principles and are applicable to trees, shrubs and woody plants.

SECTION 5.05 CARE OF REGULATED TREES

All owners of *Regulated Trees* are to follow the required maintenance standards set forth in this *Manual*. If special pruning or situations require a variance from these Standards, it is the responsibility of the project arborist and property owner to clarify why the changes are needed and review them with the City Arborist.

Required Practices

SECTION 5.10 PROHIBITED ACTS

Improper maintenance may constitute a prohibited act as defined by the Palo Alto Municipal Code, Chapter 8.10.050 and a violation which may be subject to penalty. The following permitted and prohibited maintenance practices for *protected* and *designated trees* apply.

Required Practices

A. Excessive Pruning

Except for clearance pruning of utility lines, traffic or abating a *Public Nuisance*, *excessive pruning* (see *Excessive Pruning, Section 1.15*) shall be considered a prohibited act.

B. Topping

Topping shall be considered a prohibited act (see *Topping, Section 1.33*). Seek alternatives to topping (see *Crown Reduction, Section 5.20-A*).

C. Other prohibited actions

Taking any action foreseeably leading to the death of a tree or permanent damage to its health, including but not limited to excessive pruning, cutting, girdling, poisoning, over watering, unauthorized relocation or transportation of a tree, or trenching, excavating, altering the grade, or paving within the dripline area of a tree (see *Palo Alto Municipal Code Chapter 8.10.020, Appendix A*).

5.15 STANDARDS FOR PRUNING REGULATED TREES

The most compelling reason to prune trees is to develop a strong, safe framework. All work to be performed on *Regulated Trees* shall be in accordance with the following standards.

Required Practices

notes:

Required Practices

A. Specifications

All specifications for working on *protected* and *designated trees* shall be written and shall be administered by a qualified arborist, and shall be designed to promote the preservation of tree structure and health.

B. Industry Standards

All work on *Regulated Trees* shall be in accordance with the most current edition of the following industry standards: (see *Performance Standards. Standard Practices for Tree Care Operations - ANSI A300-1995 Appendix G; Safety Standards, ANSI Z133.1-1994, Appendix F; and Tree Pruning Guidelines, Appendix E*).

Required Practices

5.20 PRUNING MATURE TREES

There are six types of pruning that may be required for use on mature *Regulated Trees* (see *ISA Tree Pruning Guidelines, Appendix E*). Prior to entering the tree, the tree worker is required to be familiar with these types of pruning as stated in the Performance Standards, ANSI, A300-1995. 'Species-specific' pruning promotes the natural shape of the tree (i.e. excurrent, decurrent, vase-shaped, fast growing, etc.).

A. Types of Pruning

- ▶ Crown Cleaning
- ▶ Crown Thinning
- ▶ Crown Raising
- ▶ Crown Restoration
- ▶ Crown Reduction
- ▶ Utility Pruning

B. Tree Injury

Climbing and pruning practices shall not injure the tree except for the pruning cuts.

C. Timing of Pruning

To reduce the probability of insect infestation, disease or infection, the following seasonal restrictions apply, except when public safety is a concern (see *Tree Pruning, Surgery and Removal, Section 2.15-F*):

- ▶ Pine (*Pinus spp.*) or Elm (*Ulmus spp.*): Do not prune May-October
- ▶ All species: Do not prune during the flush of spring shoot growth
- ▶ Trees with thin bark: Do not prune in summer when sun scald injury may be a factor
- ▶ Deciduous trees (leafless in winter): Best pruned November-February
- ▶ Hazardous trees of any species may be pruned any time of the year for abatement reasons

Recommended Practices

5.25 PRUNING DISTRESSED TREES

Distressed trees require as much leaf area as possible to overcome stressed conditions. To avoid additional injury, the following measures shall be followed for these trees.

A. Injury or Disturbance

If a tree has been damaged by injury or disturbance, delay pruning until deadwood becomes evident (typically 1-3 years after injury). Crown cleaning is then recommended.

B. Neglect

Trees that have received little or no care or maintenance may need moderate crown thinning, reduction of end weights or entire crown restoration.

5.30 PRUNING YOUNG TREES

The average life expectancy for trees growing in harsh urban conditions is 7-10 years. By pruning trees early, it will improve life expectancy and is a proven, cost-effective measure. Added benefits are also reflected in safer trees with fewer branch failures. For trees that serve as a replacement for a *protected* or *designated trees*, they shall be pruned in the following way:

- ▶ Young trees should be pruned during the second year after planting to improve their structure, and only minor crown cleaning every 3-7 years thereafter. Refer to *ISA Tree Pruning Guidelines (see Appendix E)*.
- ▶ Do not top the main leader except to position the lowest main branch. Other main branches should be spaced at least 18-inches apart to alleviate a tight grouping branches.
- ▶ Select permanent branching and allow temporary low branching on the lowest part of the trunk to remain.

5.40 FERTILIZING STANDARDS

This section outlines performance standards for fertilizing and apply only if fertilizing is specified. Fertilizing mature trees is generally not necessary. Fertilizing may be specified for trees that will be impacted by upcoming disturbance, grade changes or a modified environment. Benefits gained from the increase stored resources may aid the tree to overcome the stress caused by disturbance.

A. Specifications

Fertilizing, if specified, shall be performed to the following standards:

- ▶ Method of application: The method shall be subsurface injection, on approximate 3-foot centers (within the root ball on young trees; 2-feet out on older trees) and out to the approximate dripline perimeter. Specific situations may justify other variations such as vertical mulch, soil-fracture or surface-broadcast methods.
- ▶ Material and Rates: Unless specified otherwise, fertilizer formula shall be a slow-release, complete fertilizer with chelate trace elements (e.g. 22-14-14 or 20-20-20) and mixed at label rates not to exceed 4-pounds nitrogen per 100-gallons of water. Extraordinary cases may require soil and tissue sampling to correct target deficiencies.

notes:
Recommended Practices

Recommended Practices

Recommended Practices

notes:

- ▶ Amount: Unless specified otherwise, volume shall be determined by mixing 10-gallons of water per inch of trunk diameter when measured at 54-inches above natural grade.
- ▶ Timing: Timing should not be detrimental to tree health. Best results are derived from applications made during the prior growing season. Apply fertilizer between May through September for best results.

5.45 WATERING SCHEDULE

Required Practices

Newly installed trees planted, including drought tolerant species, are dependent upon supplemental irrigation until established, typically for two years. Periods of extreme heat, wind or drought may require more or less water than recommended in these specifications. The method and amount that is applied may vary depending upon soil composition, heat, wind, planted in turf or ground cover, periods of abnormal rainfall or in poorly drained soils (see *Drainage, Section 3.40-C*). The watering of *protected* or *designated trees* or their replacements shall follow these standards:

A. New trees

During the establishment period (1-2 years) trees should be watered thoroughly to their root depth as frequently as needed. A watering schedule is to be submitted at the preconstruction meeting. The schedule is to include watering frequency and quantity. The minimum standards shall be as follows:

- ▶ 1-3 months in the ground: 4 times per month or as necessary
- ▶ 4-6 months in the ground: 2 times per month or as necessary
- ▶ 7-12 months in the ground: 1 time per month or as necessary

B. Mature trees

- ▶ Most species: 1 time per month during irrigation season (usually March through September)
- ▶ Coast Live Oak, Valley Oak and Blue Oak: deep water in May and September — do not water during other months. For oaks already in the vicinity of irrigated conditions, automatic sprinklers or regular watering shall not be allowed to spray on or within three feet of the trunk. The water shall not be allowed to pool or drain towards the trunk.

C. Watering Methods

The following options shall fulfill the watering requirements. One or more of the following may be utilized dependent upon unique circumstances subject to the *City Arborist* determination. The options are as follows:

1. Automated Watering Systems. All new *street trees* planted within the right-of-way and *designated trees* shall be provided with one of the following automatic watering systems. All tree irrigation is to be consistent with current *Landscape Water Efficiency Standards for the City of Palo Alto*. Other city maintained systems shall be per Parks Department specifications.

PAMC 12.32.040

- ▶ Bubbler heads (Preferred). One or two bubbler heads mounted on flexible tubing are to be placed adjacent to or on top of the root ball. The placement of bubbler within an aeration tube is not allowed.
- ▶ Drip Loop system. A continuous loop of drip tubing circling around the trunk at a point two-thirds out from the trunk to the edge of the root ball (for new trees 36-inch box size and greater, a second loop of drip tubing is required at a point just beyond the root ball on native soil).
- ▶ Hand watering systems. Recommended for trees that are part of a development project that must be watered to insure tree survival during the course of construction until automatic irrigation is installed.
- ▶ Flood watering. Newly installed trees must be 'flood or basin-watered' on top of the root ball to allow the water to infiltrate through the root zone.
- ▶ Subsurface injections using a hydraulic spray pump (practical for use in hard, compacted soils or steep hillsides).
- ▶ Soaker hose. Slow, deep watering using a garden type soaker hose.
- ▶ Wetting agent. A root ball that has been allowed to dry out beyond the wilting point shall require the addition of a wetting agent to the water (such as Aqua-grow or equivalent).

notes:

D. Amount

Unless otherwise specified, the volume of water applied at each irrigation should be in the range of 10-gallons per inch of trunk diameter when measured at 54-inches above natural grade. The final decision of whether to water or not should be based on accurate soil probe samples that are taken from the root ball.

5.50 SOIL IMPROVEMENT

During development, compaction of the soil is the largest single factor responsible for the decline of oaks and older trees. Ninety percent of the damage to the upper eighteen inches of soil occurs during the first pass of heavy equipment - and cannot be reversed. Every effort to avoid compaction of soil porosity within the tree protection zone shall be taken at all times (*see Soil Compaction, Section 1.29*). When required by the conditions of *Discretionary Development Approval* for a project or as mitigation for injury or a prohibited action, the following performance standards for improvement of compacted or damaged soil shall be implemented:

Required Practices

A. Aeration

Soil that is damaged or compacted within the dripline of *protected* or *designated trees* shall be loosened or aerated to promote root growth and enhance tree vitality. One of the following aeration methods shall be specified in an effort to correct compacted soil conditions:

Required Practices

- ▶ *Vertical Mulching*: auger holes 2 to 4-inch diameter, 2 to 3-feet deep, on 4-foot centers and backfilled with porous material such as perlite, vermiculite or volcanic rock (*see Definitions, Section 1.41*)

notes:

- ▶ Radial Trenching: with an air excavator, excavate a soil trench 3 to 6-inches wide and a minimum of 12-inches deep from (approximately) 3-feet from the trunk out to the dripline area. The trenches shall radiate out from one foot apart at the closest point.
- ▶ *Soil-fracturing* with a pneumatic air-driven device (see *Definitions, Section 1.30*)
- ▶ Subsurface injections under moderate hydraulic pressure using a three foot probe and applied on 3-foot centers under the dripline

Required Practices

B. Drainage

Adequate drainage must be provided to the surrounding soil for the planting of new trees. If the trees are to be planted in impermeable or infertile soil, and water infiltration rates are less than 2-inches an hour, then one of the following drainage systems or other approved measures must be implemented (see *Drainage, Section 3.40-C*).

- ▶ French drain, a minimum of three feet in depth
- ▶ Drain tiles or lines beneath the trees
- ▶ Auger six drain holes at the bottom perimeter of the planting pit, a minimum of 4-inches in diameter, 24-inches deep and filled with medium sand or fine gravel

5.60 INSECT AND DISEASE CONTROL

Generally, insect populations do not threaten tree health to the point of mortality. More often, when their populations become too great they create a nuisance. For example, scale on tulips or aphids feeding on purple leaf plums produce sticky honeydew that may be a nuisance if dripping on cars or at a storefront entry. Occasionally, however, pests such as Oak or Tussock Moth larvae can defoliate and severely damage a tree. If action is warranted, Integrated Pest Management (I.P.M.) suggests that the pest source be identified and targeted with a specific and timely treatment. If insects or disease can lead to the death of a *protected* or *designated tree*, then it is the responsibility of the property owner to evaluate the condition according to the following guidelines and treat the problem in a timely fashion to prevent further deterioration of the tree

Recommended Practices

A. Insects

For treatment, consult a pest control operator that is licensed by the California Department of Pesticide Regulation. Accurate timing is critical for success.

- ▶ Nontoxic materials should be used whenever possible to control leaf-chewing insects

Required Practices

B. Disease and Decay - above ground

Disease such as heart-rot decay that erodes the health or weakens the structure of a *protected* or *designated tree* may compromise the safety of people or property (see *Hazardous Tree Determination, Section 4.0*). It is the property owner's responsibility to correct a known hazardous condition in a timely fashion.

- ▶ Consult with a *certified arborist* for remedy possibilities, for example, pruning out infected branches, thinning, or the spray application of a chemical treatment.

C. Disease - below ground

Soilborne diseases, such as Oak Root Fungus (*Armillaria mellea*) or Root Rot (*Phytophthora sp.*), are present in Palo Alto soils. Often, a poor landscape design surrounding old trees encourages harmful, and often lethal diseases. The following conditions that favor a disease environment must be avoided.

- ▶ Conditions to avoid: Compacting of the soil within the tree's dripline, adding fill dirt, rototilling, trenching, removing soil from the tree root area, and excessive or regular watering on or near the tree trunk area and planting incompatible water-loving plants within the tree's dripline. Combined with poorly-drained soil, these factors often activate normally dormant fungi to become opportunistic and infect the tree to cause the decline and eventual death of the tree. This decline can be slow and may not be evident for many years.
- ▶ Landscape Design
When planning landscaping around a *protected* or *designated tree*, an evaluation of the tree and soil must be performed to determine if there is a disease present. If the tree is diseased and landscaping will contribute to decline, permanent damage or render it hazardous, it is the obligation of the property owner to take reasonable measures to reduce or eliminate the conditions that may cause the decline of the protected or designated tree.
- ▶ To identify cultural conditions that may lead to diseases such as Oak Root Fungus, Verticillium, Phytophthora or other soilborne fungi, review the *Sunset Western Garden Book* or consult with a *Certified Arborist* (see *Certified Arborist, Section 1.4*).
- ▶ Use plants under oaks that have low to moderate water needs. Refer to a list of these plants (see *Plant List for Use Under Oaks, Appendix L*), *Sunset Western Garden Guide* or call Canopy: Trees For Palo Alto at (650) 964-6110.
- ▶ Plants selected for use under an oak should not need water more than once a month. Use a drip system to irrigate around an oak so that runoff does not flood the area.

D. Foliar disease

Leaf spot or galls may be chronic or reoccur with specific seasons. Though many of these diseases destroy leaf tissue and become unsightly, they may not significantly reduce the trees health and therefore need not be treated.

5.80 FRUIT CONTROL

While all trees produce flowers or fruit of some kind, some trees can be considered a nuisance if the use area is not compatible with the litter generated by the tree. For example, the dropping fruit of the European Olive (*Olea europaea*), American Sweet Gum (*Liquidamber styraciflua*), or acorn drip of a Holly Oak (*Quercus ilex*) may be a safety hazard if it is in the proximity of a handicap ramp or other high pedestrian area and will thus justify control measures. Control can only be successful if materials are applied carefully at optimum timing. For treatment to control the situation, consult a pest control operator that is licensed by the California Department of Pesticide Regulation.

notes:

Required Practices

Recommended Practices

notes:

Recommended Practices

5.90 FIRE PROTECTION: KEEPING THE OPEN SPACE, PARKS & COMMUNITY SAFE

The following measures are recommended but not required. If followed, they may help avoid a catastrophic and irreplaceable fire loss to persons, houses, hillsides and mature trees that are centuries old.

Checklist:

- Keep dry grass mowed below 6-inches.
- A 30-foot defensible space should be obtained.
- No vegetation growing or combustible storage under decking.
- No tree canopy within 10-feet of chimney spark arrester.
- Break up solid areas of continuous plant growth which create a 'fire-ladder'.
- Ask nursery professionals about fire-resistant shrubs to use in landscaping.
- Keep tree well watered, regularly pruned and in healthy condition.
- Prevent build-up of leaves and old branches.
- No firewood storage within 10-feet of structures.
- Make sure your driveway, road and bridges allow access for fire equipment (13-foot vehicle clearance needed).
- Homes adjacent to slopes over 30% will need additional clearing of vegetation from the structure 100-200 feet to protect against radiant and convective heat currents and flame reach.

5.95 TIPS FOR SELECTING AN ARBORIST

A. Who should you look for?

Hiring a tree care provider deserves careful consideration and caution. A mistake can be expensive and long-lasting, while the right choice can assure health, beauty and longer life for your trees and landscape. The following suggestions will help you select an arborist:

- ▶ Check the phone directory, usually under trees or tree care service. Listings in the directory should indicate some degree of permanence. Look for professional membership affiliations. Membership does not guarantee quality, but a lack of it may cast doubt on the company's commitment to professionalism.
- ▶ Beware of door-knockers. Most reputable companies have all the work they can handle without going door-to-door.
- ▶ Request that the sales person be an arborist or tree worker that has been certified through a program of the International Society of Arboriculture (ISA). This program is the standard of performance for appropriate training, experience and knowledge about tree care. Additionally, it is best to use an arborist who is familiar with the trees and ordinances of the City of Palo Alto.

Recommended Practices

- ▶ Require a certificate of insurance, including liability for personal injury and property damage (such as your house and your neighbor's), and workers compensation. Phone their insurance company to make certain each policy is current. Under some circumstances, the property owner may be held financially responsible if an uninsured worker is hurt on your property, or if damage is done to a neighbor's property!
- ▶ Ask for local references and other jobs the company or individual has done in Palo Alto. Experience, education and good reputation are signs of a good arborist.
- ▶ Have more than one arborist look at your job and give you a written estimate that clearly states their scope of work. Don't expect a company to lower its bid to match another's bid. Be willing to pay for the estimate if necessary. Two or more opinions and estimates are worth the extra effort.
- ▶ A good arborist will offer a wide range of services including removal, pruning, fertilizing, cabling, pest control, etc.
- ▶ A good arborist will not recommend topping (Section 1.32) except in rare circumstances (such as; crown restoration after severe physical or wind damage, or for a formal setting in a restricted space).
- ▶ A knowledgeable arborist will not use climbing spikes if the tree is to remain in the landscape. These should be used only for tree removal.
- ▶ Beware of an arborist who is eager to remove a living tree. Removal clearly should be a last resort.

notes:

B. The Contract for Services

To be assured of having your work performed to the standards you expect, a contract should include all the necessary assurances. Most companies will provide their own contract and should include the following basics:

- ▶ Dates that work will begin and end.
- ▶ List exactly what will be done (*see Types of Pruning, Section 5.20*). If your tree is to be sprayed, get a written statement detailing the insect or disease to be treated, the chemical to be used and what precautions you need to take (cover patio furniture, keep pets inside, etc.). If fertilizer, how many pounds of fertilizer per inch of trunk diameter will be applied and by what method.
- ▶ Cleanup procedures should be listed and whether firewood will need to be cut (and into what lengths) should both be mentioned.
- ▶ Clarify if a tree removal includes grinding the stump and surface roots and if so, how deep?
- ▶ Will they remove grindings and backfill the hole?
- ▶ The total dollar amount you will be charged.
- ▶ Work is usually priced in one of two ways: (a) as a single price for the job, or (b) on an hourly basis plus materials. When using the latter, be sure to include the wording, "...but not to exceed..."

Recommended Practices

notes:

C. Using Arborists for Preventative Care

- ▶ A proactive tree and plant health care program can assure that minor, early pruning will prevent major, corrective pruning later on. An annual inspection will likely help you develop the landscape relatively hazard-free and display attractive curb appeal.
- ▶ Consulting arborists also offer advice and appraisals, diagnosis of problems and recommend treatment. They also can serve as a 'second opinion', if needed.



END OF SECTION

CITY OF PALO ALTO
TREE TECHNICAL MANUAL
STANDARDS AND SPECIFICATIONS

notes:

SECTION 6.00 TREE REPORTS

INTRODUCTION

An arborist report is needed for development projects and tree removal permits. The report must be prepared by a certified arborist for the applicant and submitted to the City for the purpose of providing accurate information and opinion regarding the condition, welfare, maintenance, preservation or value of a *protected or designated* tree.

Required Practices

A. When a written report is required

Generally, there are two circumstances in which tree reports are required: 1) when a tree removal permit is sought, and 2) to complete and verify a site plan, assess tree impacts and establish tree protection for property development when within the dripline of a *protected or designated tree*. Types of report formats are: *Letter Report, Tree Survey, Tree Protection and Preservation Plan* and *Tree Appraisal*.

B. Who may prepare the report

The tree report is to be prepared by a certified arborist retained by the applicant or property owner. This person shall possess a current ISA certification (*see Certified Arborist, Section 1.00*); be a member of the American Society of Consulting Arborists; or a member of good standing in another nationally recognized tree research, care, and preservation organization.

6.05 REPORT FOR INDIVIDUAL TREE REMOVAL PERMIT

Required Practices

A. Tree Removal Permit

The procedure (*see Tree Removal Checklist, Appendix M and Removal of Regulated Trees, Section 3.05*) involves three steps which must be completed and approved to *remove a protected tree*. The information contained within the application will be reviewed by the City Arborist for written response within approximately 10 working days.

B. Submittals

For this purpose, the following information is to be submitted to the City for review:

- ▶ A completed application for the protected tree removal (delivered to the City of Palo Alto, Development Center, 285 Hamilton Avenue, Palo Alto, CA 94301)
- ▶ A filing fee (\$145) for review and records management. (FY Fee Schedule Application fee - \$125, records management \$20)
- ▶ An arborist report prepared by a certified arborist

C. Written authorization

To *remove* a publicly-owned tree (*street tree*), the property owner shall first have obtained written permission from Public Works Operations or City Arborist. For a *protected tree* on private property, the permit from the Planning Division must be on site when the tree is being removed. For a *designated tree* in property development, the approved plans serve as the approval and no separate written permit is needed.

notes:

6.10 TYPE OF REPORT: LETTER FORMAT

Required Practices

A. Letter Report

A brief format is acceptable for (1) and (2) below, and can generally be used for assessing one or two trees. The report is to be on letterhead stationery of the individual preparing the report, including their ISA Certification number.

1. Removal

If for a tree *removal* (i.e., an application request for a single tree removal only, not in connection with a property development), the report shall provide information and determination whether the tree is dead, hazardous or constitutes a nuisance under PAMC Section 8.04.050 (2).

2. Development

If for development on a single family residential lot (not a subdivision), the report shall also clearly indicate whether or not any *protected* or *designated tree* is so close to the 'building area or building footprint' that it will be killed or permanently injured by disturbance. The report must make specific recommendations to protect and preserve the tree during the course of construction that are consistent with the specifications within this *Manual* (see *Tree Protection & Presentation Report, Section 6.30*).

Required Practices

6.15 LETTER REPORT - SUBMITTALS

A. Standard information

All letter reports shall contain the following information: Arborist name and certification number; purpose of the report and for whom; site address; date of the inspection(s); a to-scale diagram of the tree(s) location, accurate size of the trunk diameter (measurement taken at 54-inches above natural grade); perimeter of leaf canopy; proximity to structures; condition of the tree health (and/or decay presence), condition of the tree structure, imminent danger of failing (ISA Hazard Rating, see *appendix C*); interface with utility services; conclusion and recommendation(s), photographs (encouraged) and Tree Protection Instructions (if needed).

B. Specific situations

Other conditions may require the following additional information on an as-needed basis if requested by the reviewing City staff: tree protection plans; appraised value (see *Tree Appraisal, Section 6.40 below*); and any other supporting information, photographs, diagrams, etc. that may be necessary.

Required Practices

6.20 TYPE OF REPORT: TREE SURVEY FORMAT

A more extensive 'Tree Survey Report' is required for all development projects except those identified in Section 6.10 above. The report shall inventory all trees that are greater than 4-inches in diameter (measured at 12-inches above natural grade) on site, including trees to be removed, relocated and retained on the property (including trees on neighboring properties that overhang the project site) and all *street trees* in the right-of-way within 30-feet of the project site (see *Tree Disclosure Statement, Appendix I*). In addition to information required in a letter report, the Tree Survey Report, shall include an inventory of the trees, site plan, appraised value (see *Appraisals, Section 6.40 below*) of the trees and any other information pertinent to the project.

6.25 SURVEY REPORT - SUBMITTALS

A. Items to include

All Tree Survey Reports shall contain the following information: Arborist name and certification number; cover letter; title page; table of contents (if necessary); purpose of the report and for whom; site address; date of the inspection(s); site plan (showing each tree location by number that correlates with the tree inventory on plans; tree inventory data (include tree species, size, health, structure, etc. for all trees on the project site, including those to be removed (tables may be used); condition of the trees (include information with respect to health, structure, decay, imminent danger of falling, existing property lines, structures and utility services) conclusion, recommendation(s) and rated for suitability for preservation. The report shall include a separate list of all *protected trees* with location numbers. If necessary, other supporting information, photographs, diagrams, etc. may be required or provided.

B. Appraised Value

The monetary value that each tree contributes to the real estate value of the property shall be determined and listed separately within the Tree Survey Report. The formula used should be noted (*see Tree Appraisal, Section 6.40 below*).

6.30 TREE PROTECTION AND PRESERVATION REPORT

All *protected or designated trees* to be retained on a development site shall be shown on approved sets of civil, building and landscape plans and shall be protected during the construction process. A *Tree Protection and Preservation Plan* submitted for review by the Planning Division is required when trees to be saved may be *injured by disturbance*. The tree preservation plan shall assume compliance with standards in Section 2.00 of this *Manual* (*see Protection of Trees During Construction, Section 2.00*). In addition, the following submittal information must be included in the report:

A. Scope & Construction Phasing

The *tree protection and preservation plan* shall identify, but not be limited to, written recommendations for the health and long-term welfare of trees that are to be followed during the following distinct phases and conditions: pre-construction; during construction, post construction, demolition activities; methods of avoiding injury, damage treatment and inspections. Schedules shall be included.

B. Tree Protection Zone

The *tree protection and preservation plan* shall establish a tree protection zone (TPZ) for each tree to be fenced and clearly outline site-specific measures for protection of the trees during construction and describe a plan for continued maintenance of those trees after construction. After project approval, any changes to the protection measures must be approved in writing, by the *City Arborist*. The tree protection plan shall include the following *site plan* elements:

notes:

Required Practices

Required Practices

notes:

6.35 SITE PLAN

Required Practices

A. Disclosure of all trees on and near the site

The property owner or designee shall provide accurate information to the project arborist to develop the tree protection measures and to enable accurate recommendations to insure their survival. This *site plan* shall accurately show the surveyed location, species, size of trunk and leaf canopy; show the dripline of any neighboring trees that may overhang the site and *street trees* that are within 30-feet on each side of the project (see *Tree Disclosure Statement, Appendix I*). Failure to show a tree on the plans and later determined to be affected by construction may require the work to stop until mitigation can be agreed upon by the property owner and the City.

B. Plans submitted to the City

In addition to the above information, final improvement plans shall include and show the following information: show the *tree protection zone* of any tree to be retained and denote a 5-foot chain link type fencing around the protected zone of each tree or group of trees (to be clearly identified as such on all plans as a bold-dashed line); permeable paving located within the dripline area; approved utility pathways; grade changes; surface and subsurface drainage and aeration systems to be used; walls, tree wells, retaining walls and grade change barriers, both temporary and permanent; landscaping and irrigation within dripline of trees.

C. Plans must show tree protection

Protective tree fencing identified within the arborist report, both written and diagrammatic, shall be clearly shown as a bold, dashed line on the approved site plans submitted for demolition, grading, construction, building permit or any other aspects that are relevant to the project.

6.40 TREE APPRAISAL

Required Practices

Landscape value may contribute from seven to 20-percent of the real estate property value. An individual tree has an inherent value to the real estate that can be determined by an appraisal prepared by a certified arborist. An appraisal is a process for determining a monetary opinion of the value of a tree as it relates to either the property, a group of trees and/or the immediate community. A qualified *certified arborist* is required to determine this value, and must exercise good and fair judgment by adjusting the basic value by the tree's condition and location. There are two methods to determine tree value; (1) the Replacement Method, based upon the size and availability of the replacement tree or, (2) the Trunk Formula Method, if the tree cannot be replaced (e.g. not sufficient room on site or it is too large to replace). In all cases, the type of formula used must be identified.

6.45 APPRAISAL METHODS

Required Practices

The certified arborist must prepare the appraisal by using the most current edition of (1) the *'Guide for Plant Appraisal'*, published by the Council of Tree and Landscape Appraisers, and (2) the most recent *'Form for Northern California'* established by the International Society of Arboriculture.

A. The Replacement Cost Method

Applies to smaller trees with a trunk size up to 4-inches in diameter or, 48-inch box size trees (replaceable.) For this method, the appraised value shall be determined by combining: price quote + transportation + planting + other costs and applying the condition and location value to the tree. The sum of these is the appraised replacement cost.

B. The Trunk Formula Method

Applies to trees that are too large for practical replacement (transplanting) and shall be appraised by: determining the basic tree value and adjusting this value by a condition and location ratings. The appraised value shall be determined by using the most recent edition of the *'Guide for Plant Appraisal'*, published by the Council of Tree and Landscape Appraisers. The Trunk Formula or Replacement Method Forms for Northern California established by the International Society of Arboriculture must be used to compute the appraised value. All trees with a stem larger than 4-inches in diameter when measured at 12-inches above natural grade shall be calculated in this manner. (See *Determining the tree value, Section 3.25*).

notes:



END OF SECTION

THIS PAGE INTENTIONALLY LEFT BLANK



ORDINANCE NO. 4362
ORDINANCE OF THE COUNCIL OF THE CITY OF PALO ALTO
ADDING CHAPTER 8.10 TO TITLE 8 OF THE PALO ALTO
MUNICIPAL CODE REGARDING TREE PRESERVATION AND
MANAGEMENT REGULATIONS

The Council of the City of Palo Alto does **ORDAIN** as follows:

SECTION 1. The City Council finds as follows:

(a) The City of Palo Alto is endowed and forested by native oaks and other heritage trees, which give the City a unique visual character and enhance property values. The vestiges of the original abundant oak forest so well adapted to much of this region, are increasingly threatened after more than a century of development. Redwood trees have a special role in Palo Alto's history due to the original "El Palo Alto" Redwood serving as a regional landmark. The City Seal includes a Redwood tree as its central focus. Redwood trees are among the tallest trees in the City and are the State Tree of California. Moreover, Redwood trees are planted widely in Palo Alto so that virtually every neighborhood has been and can be impacted by the removal of large Redwoods. Preservation and maintenance of the remaining healthy native oaks, redwoods and other heritage trees will retain their great historic, aesthetic, and environmental value for the benefit of all residents. Preservation of these trees is important for the following reasons:

- (1) To protect and conserve the aesthetic and scenic beauty of the City;
- (2) To encourage and assure quality development;
- (3) To protect the environment of the city;
- (4) To aid in the reduction of air pollution by protecting the known capacity of trees to produce oxygen and ingest carbon dioxide;
- (5) To help reduce potential damage from wind;
- (6) To provide shade;
- (7) To protect property values;
- (8) To act as a noise barrier; and
- (9) To assist in the absorption of rainwater into the ground, thereby protecting against potential damages from soil erosion and flooding, as well as reducing the cost of handling storm water by artificial means.

(b) In order to promote the health, safety, and general welfare of the residents of the City, while recognizing the interests of the property owners in developing, maintaining, and enjoying their property, it is necessary to enact regulations for protection of specified trees on private property within the City.



**Chapter 8.10 TREE PRESERVATION
AND MANAGEMENT REGULATIONS***

Sections:

- 8.10.010 Purpose.
- 8.10.020 Definitions.
- 8.10.030 Tree Technical Manual.
- 8.10.040 Disclosure of information regarding existing trees.
- 8.10.050 Prohibited acts.
- 8.10.060 No limitation of authority under Titles 16 and 18.
- 8.10.070 Care of protected trees.
- 8.10.080 Development conditions.
- 8.10.090 Designation of heritage trees.
- 8.10.100 Responsibility for enforcement.
- 8.10.110 Enforcement - Remedies for Violation.
- 8.10.120 Fees.
- 8.10.130 Severability.
- 8.10.140 Appeals.

Editor's Note: Prior Ordinance History: Section 2 of Ord. 4362 was previously codified herein, and was not specifically repealed by adoption of Ord. 4568.

8.10.010 Purpose

The purpose of this chapter is to promote the health, safety, welfare, and quality of life of the residents of the city through the protection of specified trees located on private property within the city, and the establishment of standards for removal, maintenance, and planting of trees. In establishing these procedures and standards, it is the city's intent to encourage the preservation of trees. (Ord. 4568 § 1 (part), 1999)

8.10.020 Definitions

For the purposes of this chapter, the following definitions shall apply:

- (a) "Basal flare" means that portion of a tree where there is a rapid increase in diameter at the confluence of the trunk and rootcrown.
- (b) "Building area" means that area of a parcel:
 - (1) Upon which, under applicable zoning regulations, a structure may be built without a variance, design enhancement exception, or home improvement exception; or
 - (2) Necessary for construction of primary access to structures located on or to be constructed on the parcel, where there exists no feasible means of access which would avoid protected trees. On single-family residential parcels, the portion of the parcel deemed to be the building area under this paragraph (b)(2) shall not exceed ten feet in width.
- (c) "Building footprint" means the two-dimensional configuration of an existing building's perimeter boundaries as measured on a horizontal plane at ground level.
- (d) "Hazardous" means an imminent hazard or threat to the safety of persons or property.
- (e) "Development" means any work upon any property in the city which requires a subdivision, planned community zone, variance, use permit, building permit, demolition permit, or other city approval or which involves excavation, landscaping or construction within the dripline area of a protected tree.
- (f) "Director" means the director of planning and community environment or his or her designee.
- (g) "Discretionary development approval" means planned community zone, subdivision, use permit, variance, home improvement exception, design enhancement exception, or architectural review board approval.
- (h) "Dripline area" means the area within X distance from the perimeter of the trunk of the tree at four and one-half feet (fifty-four inches) above natural grade where X equals a distance ten times the diameter of the trunk as measured four and one-half feet (fifty-four inches) above natural grade.
- (i) "Excessive pruning" means removal of more than one-fourth of the functioning leaf and stem area of a tree in any twelve-month period, or removal of foliage so as to cause the unbalancing of a tree.
- (j) "Protected tree" means:
 - (1) Any tree of the species *Quercus agrifolia* (Coast Live Oak) or *Quercus lobata* (Valley Oak) which is eleven and one-half inches in diameter (thirty-six inches in circumference) or more when measured four and one-half feet (fifty-four inches) above natural grade; and



(2) Any Redwood tree (species *Sequoia sempervirens*) that is eighteen inches in diameter (fifty-seven inches in circumference) or more when measured four and one-half feet (fifty-four inches) above natural grade. (Ord. 4680 § 2, 2001)

(3) A heritage tree designated by the city council in accordance with the provisions of this chapter.

(k) "Remove" means any of the following:

(1) Complete removal, such as cutting to the ground or extraction, of a tree.

(2) Taking any action foreseeably leading to the death of a tree or permanent damage to its health; including but not limited to excessive pruning, cutting, girdling, poisoning, overwatering, unauthorized relocation or transportation of a tree, or trenching, excavating, altering the grade, or paving within the dripline area of a tree.

(l) "Tree" means any woody plant which has a trunk four inches or more in diameter at four and one-half feet above natural grade level.

(m) "Tree report" means a report prepared by an arborist certified by the International Society of Arboriculture or another nationally recognized tree research, care, and preservation organization.

(n) "Tree Technical Manual" means the regulations issued by the city manager to implement this chapter.

(Ord. 4680 § 2, 2001; Ord. 4568 § 1 (part), 1999)

8.10.030 Tree Technical Manual

The city manager, through the departments of public works and planning and community environment, shall issue regulations necessary for implementation of this chapter, which shall be known as the Tree Technical Manual. The Tree Technical Manual will be made readily available to the public and shall include, but need not be limited to, standards and specifications regarding:

(a) Protection of trees during construction;

(b) Replacement of trees allowed to be removed pursuant to this chapter;

(c) Maintenance of protected trees (including but not limited to pruning, irrigation, and protection from disease);

(d) The format and content of tree reports required to be submitted to the city pursuant to this chapter;

(e) The criteria for determining whether a tree is dangerous within the meaning of this chapter.

(Ord. 4568 § 1 (part), 1999)

8.10.040 Disclosure of information regarding existing trees

(a) Any application for discretionary development approval, or for a building or demolition permit where no discretionary development approval is required, shall be accompanied by a statement by the property owner or authorized agent which discloses whether any protected trees exist on the property which is the subject of the application, and describing each such tree, its species, size, dripline area, and location. This requirement shall be met by including the information on plans submitted in connection with the application.

(b) In addition, the location of all other trees on the site and in the adjacent public right of way which are within thirty feet of the area proposed for development, and trees located on adjacent property with canopies overhanging the project site, shall be shown on the plans, identified by species.

(c) The director may require submittal of such other information as is necessary to further the purposes of this chapter including but not limited to photographs.

(d) Disclosure of information pursuant to this section shall not be required when the development for which the approval or permit is sought does not involve any change in building footprint nor any grading or paving.

(e) Knowingly or negligently providing false or misleading information in response to this disclosure requirement shall constitute a violation of this chapter.

(Ord. 4568 § 1 (part), 1999)

8.10.050 Prohibited acts

It shall be a violation of this chapter for anyone to remove or cause to be removed a protected tree, except as allowed in this section:

(a) In the absence of development, protected trees shall not be removed unless determined by the director of planning and community environment, on the basis of a tree report prepared by a certified arborist for the applicant and other relevant information, that the tree should be removed because it is dead, is hazardous, is a detriment to or crowding an adjacent protected tree, or constitutes a nuisance under Section 8.04.050(2) of this code.

(b) In the case of development on a single-family residential lot, other than in connection with a subdivision:

(1) Protected trees shall not be removed unless the trunk or basal flare of the protected tree is touching or within the building footprint, or the director of planning and community environment has determined, on the basis of a tree report prepared by a certified arborist for the applicant and other relevant information, that the tree should



be removed because it is dead, is hazardous, is a detriment to or crowding an adjacent protected tree, or constitutes a nuisance under Section 8.04.050(2) of this code.

(2) If no building footprint exists, protected trees shall not be removed unless the trunk of the tree is located in the building area, or the director of planning and community environment has determined, on the basis of a tree report prepared by a certified arborist for the applicant and other relevant information, that the tree should be removed because it is dead, is hazardous, is a detriment to or crowding an adjacent protected tree, or constitutes a nuisance under Section 8.04.050(2) of this code.

(3) If removal is allowed because the tree trunk is located in the building footprint, or the trunk or basal flare is in the building area, or because the director of planning and community environment has determined that the tree is so close to the building area that construction would result in the death of the tree, the tree removed shall be replaced in accordance with the standards in the Tree Technical Manual.

(c) In connection with a proposed subdivision of land into two or more parcels, no protected tree shall be removed unless removal is unavoidable due to restricted access to the property or deemed necessary to repair a geologic hazard (landslide, repairs, etc.). The tree removed shall be replaced in accordance with the standards in the Tree Technical Manual. Tree preservation and protection measures for any lot that is created by a proposed subdivision of land shall comply with the regulations of this chapter.

(d) In all circumstances other than those described in paragraphs (a), (b) and (c) of this section, protected trees shall not be removed unless one of the following applies:

(1) The director of planning and community environment has determined, on the basis of a tree report prepared by a certified arborist for the applicant and other relevant information, that the tree should be removed because it is dead, dangerous or constitutes a nuisance under Section 8.04.050(2). In such cases, the dripline area of the removed tree, or an equivalent area on the site, shall be preserved from development of any structure unless removal would have been permitted under paragraph (2), and tree replacement in accordance with the standards in the Tree Technical Manual shall be required.

(2) Removal is permitted as part of project approval under Chapter 18.76 (Permits and Approvals) of this code, because retention of the tree would result in reduction of the otherwise-permissible building area by more than twenty-five percent. In such a case, the approval shall be conditioned upon replacement in accordance with the standards in the Tree Technical Manual.

(Ord. 4826 § 4, 2004; Ord. 4680 § 3, 2001; Ord. 4568 § 1 (part), 1999)

8.10.60 No limitation of authority under Titles 16 and 18

Nothing in this chapter limits or modifies the existing authority of the city under Title 18 (Zoning Ordinance) to require trees and other plants not covered by this chapter to be identified, retained, protected, and/or planted as conditions of the approval of development. In the event of conflict between provisions of this chapter and conditions of any permit or other approval granted pursuant to Title 16 or Title 18, the more protective requirements shall prevail.

(Ord. 4826 § 5, 2004; Ord. 4568 § 1 (part), 1999)

8.10.070 Care of protected trees

(a) All owners of property containing protected trees shall follow the maintenance standards in the Tree Technical Manual.

(b) The standards for protection of trees during construction contained in the Tree Technical Manual shall be followed during any development on property containing protected trees. (Ord. 4568 § 1 (part), 1999)

8.10.080 Development conditions

(a) Discretionary development approvals for property containing protected trees will include appropriate conditions providing for the protection of such trees during construction and for maintenance of the trees thereafter.

(b) It shall be a violation of this chapter for any property owner or agent of the owner to fail to comply with any development approval condition concerning preservation, protection, and maintenance of any tree, including but not limited to protected trees.

(Ord. 4568 § 1 (part), 1999)

8.10.090 Designation of heritage trees

(a) Upon nomination by any person and with the written consent of the property owner(s), the city council may designate a tree or trees as a heritage tree.

(b) A tree may be designated as a heritage tree upon a finding that it is unique and of importance to the community due to any of the following factors:

(1) It is an outstanding specimen of a desirable species;



- (2) It is one of the largest or oldest trees in Palo Alto;
- (3) It possesses distinctive form, size, age, location, and/or historical significance.
- (c) After council approval of a heritage tree designation, the city clerk shall notify the property owner(s) in writing. A listing of trees so designated, including the specific locations thereof, shall be kept by the departments of public works and planning and community environment.
- (d) Once designated, a heritage tree shall be subject to the provisions of this chapter unless removed from the list of heritage trees by action of the city council. The city council may remove a tree from the list upon its own motion or upon written request by the property owner. Request for such action must originate in the same manner as nomination for heritage tree designation.
(Ord. 4568 § 1 (part), 1999)

8.10.100 Responsibility for enforcement

The following designated employee positions may enforce the provisions of this chapter by the issuance of citations: chief building official, assistant building official, code enforcement officer, planning arborist.
(Ord. 4568 § 1 (part), 1999)

8.10.110 Enforcement - Remedies for Violation

In addition to all other remedies set forth in this code or otherwise provided by law, the following remedies shall be available to the city for violation of this chapter:

- (a) Stop Work - Temporary Moratorium.
 - (1) If a violation occurs during development, the city may issue a stop work order suspending and prohibiting further activity on the property pursuant to the grading, demolition, and/or building permit(s) (including construction, inspection, and issuance of certificates of occupancy) until a mitigation plan has been filed with and approved by the director, agreed to in writing by the property owner(s), and either implemented or guaranteed by the posting of adequate security. The mitigation plan shall include measures for protection of any remaining trees on the property, and shall provide for replacement of each tree removed on the property or at locations approved by the director of planning and community and by the director of public works, if replacement is to occur on public property. The replacement ratio shall be in accordance with the standards set forth in the Tree Technical Manual, and shall be at a greater ratio than that required where tree removal is permitted pursuant to the provisions of this chapter.
 - (2) If a violation occurs in the absence of development, or while an application for a building permit or discretionary development approval for the lot upon which the tree is located is pending, the director may issue a temporary moratorium on development of the subject property, not to exceed eighteen months from the date the violation occurred. The purpose of the moratorium is to provide the city an opportunity to study and determine appropriate mitigation measures for the tree removal, and to ensure measures are incorporated into any future development approvals for the property. Mitigation measures as determined by the director shall be imposed as a condition of any subsequent permits for development on the subject property.
- (b) Civil Penalties.
 - (1) As part of a civil action brought by the city, a court may assess against any person who commits, allows, or maintains a violation of any provision of this chapter a civil penalty in an amount not to exceed five thousand dollars per violation.
 - (2) Where the violation has resulted in removal of a tree, the civil penalty shall be in an amount not to exceed five thousand dollars per tree unlawfully removed, or the replacement value of each such tree, whichever amount is higher. Such amount shall be payable to the city. Replacement value for the purposes of this section shall be determined utilizing the most recent edition of the Guide for Plant Appraisal, published by the Council of Tree and Landscape Appraisers.
- (c) Injunctive Relief. A civil action may be commenced to abate, enjoin, or otherwise compel the cessation of such violation.
- (d) Costs. In any civil action brought pursuant to this chapter in which the city prevails, the court shall award to the city all costs of investigation and preparation for trial, the costs of trial, reasonable expenses including overhead and administrative costs incurred in prosecuting the action, and reasonable attorney fees.
(Ord. 4568 § 1 (part), 1999)

8.10.120 Fees

Tree reports required to be submitted to the city for review and evaluation pursuant to this chapter shall be accompanied by the fee prescribed therefor in the municipal fee schedule.
(Ord. 4568 § 1 (part), 1999)



8.10.130 Severability

If any provision of this chapter or the application thereof to any person or circumstance is held to be invalid by a court of competent jurisdiction, such invalidity shall not affect any other provision of this chapter which can be given effect without the invalid provision or application, and to this end the provisions of this chapter are declared to be severable.

(Ord. 4568 § 1 (part), 1999)

8.10.140 Appeals

Any person seeking the director's approval to remove a protected tree pursuant to the ordinance codified in this chapter who is aggrieved by a decision of the director may appeal such decision in accordance with the procedures set forth in Chapter 18.78 (Appeals).

(Ord. 4826 § 6, 2004; Ord. 4568 § 1 (part), 1999) *(note: old reference prior to 7/04_is 16.48.090 of Chapter 16.48)*



TREE CITY-- USA Designation

The National Arbor Day Foundation, in cooperation with the U. S. Forest Service and the National Association of State Foresters, recognizes towns and cities across America that meet the standards of the TREE CITY USA program. At least half of the trees in a typical city are on public property...along streets, in parks, and around public buildings. The TREE CITY USA program is designed to recognize those communities that effectively manage their public tree resources and to encourage the implementation of community tree management based on four TREE CITY USA standards.

These four standards provide structure for a community forestry program, require that program to demonstrate success based on the judgement of the state forester's office, and provide for an awareness and appreciation of trees among the residents of the community. TREE CITY USA is an ongoing community improvement program, and the City of Palo Alto applies for certification each year.

Ongoing TREE CITY USA recognition makes a strong contribution to our community's pride, and keeps us in touch with other communities and resources which can help us improve Palo Alto's program.

Palo Alto Response--

The City of Palo Alto has achieved the national distinctive rating of TREE CITY USA for over 15 years, having met or exceeded all of the required standards of recognition. Management and protection of trees on public and private lands is addressed pro-actively rather than reactively. The coalition of city staff, community residents and the non-profit organization, Canopy: Trees for Palo Alto, has proven successful and fruitful far beyond what either of these segments alone could have independently accomplished.

Application Procedures

TREE CITY USA Standards

Standard 1: A Tree Board or Department

A tree board is a group of concerned citizens, usually volunteer, charged by ordinance to develop and administer a comprehensive community tree management program for the care of trees on public property. Tree boards usually function with the aid of professional foresters. In communities with a population of more than 10,000, city forestry departments with salaried employees are often feasible. These departments may or may not be supported by advisory boards or administrative commissions.

Palo Alto Response--

In 1982, The City of Palo Alto adopted the comprehensive Palo Alto Street Tree Management Plan, and is administered by the managing arborist and competent professional staff in the Department of Public Works--Operations.

Standard 2: A Community Tree Ordinance

The community tree ordinance needs to designate the tree board of department and give them the responsibility for writing and implementing the annual community forestry work plan. The ordinance should determine public tree care policies for planting, maintenance, and removals. Ideally, the city tree ordinance will make provisions for establishing and updating a list of recommended street tree species to be planted with spacing and location requirements. A sample tree ordinance may be obtained by writing The National Arbor Day Foundation.



Palo Alto Response--

In 1976, the City of Palo Alto adopted a community tree ordinance, adding the Tree Preservation and Management Regulations to Title 8 of the Municipal Code, and is administered by the managing arborist in the Department of Planning and Community Environment.

TREE CITY USA Standards (continued)

Standard 3: A Community Forestry Program with an Annual Budget of at least \$2 per capita

Many communities begin their program by taking an inventory of the trees growing on public property. The species, location, and condition of each tree are noted (i.e. healthy, needs pruning, should be removed, etc.) and the inventory data is summarized in a written report for presentation and approval by the city council. The report should be an objective analysis of the present state of the urban forest with recommendations for future management. The essential, ongoing activity for the care of trees along streets, in parks, and in other public places is the community forestry program. The annual work plan should address planting, watering and fertilizing, dead and hazardous tree removal, safety and fine pruning, and insect and disease control. To be named as a TREE CITY USA, a town or city must annually spend at least \$2 per capita for its annual community forestry program. Consider all funds spent for tree care--budget for street tree department or board, park department's tree expenditures, dead tree removal, etc.

Palo Alto Response--

The City of Palo Alto, with a current population of 61,000, far exceeds the minimum requirements for this standard with a commitment to maintaining and replenishing its street and parklands and developed open space areas.

Standard 4: An Arbor Day Observance and Proclamation

An Arbor Day observance can be simple and brief or an all-day or all-week observance. A proclamation issued by the mayor must accompany the observance and declare the observance of Arbor Day in the community. A free "Celebrate Arbor Day!" packet can be obtained by writing The National Arbor Day Foundation. Along with ideas for celebrating the holiday, the packet contains a sample proclamation.

Palo Alto Response--

The City of Palo Alto annually celebrates Arbor Day publicly with recognition of California Arbor Day, March 7, a proclamation issued by the Mayor, media announcements and in partnership with Canopy: Trees for Palo Alto activities.



A Photographic Guide to the Evaluation of Hazard Trees in Urban Areas
TREE HAZARD EVALUATION FORM 2nd Edition

Site/Address: _____
Map/Location: _____
Owner: public _____ private _____ unknown _____ other _____
Date: _____ Inspector: _____
Date of last inspection: _____

| HAZARD RATING: | | | | | | |
|--------------------------------|---|--------------|---|---------------|---|---------------|
| Failure Potential | + | Size of part | + | Target Rating | = | Hazard Rating |
| _____ | | _____ | | _____ | | _____ |
| _____ Immediate action needed | | | | | | |
| _____ Needs further inspection | | | | | | |
| _____ Dead tree | | | | | | |

TREE CHARACTERISTICS

Tree #: _____ Species: _____
DBH: _____ # of trunks: _____ Height: _____ Spread: _____
Form: generally symmetric minor asymmetry major asymmetry stump sprout stag-headed
Crown class: dominant co-dominant intermediate suppressed
Live crown ratio: _____ % Age class: young semi-mature mature over-mature/senescent
Pruning history: crown cleaned excessively thinned topped crown raised pollarded crown reduced flush cuts cabled/braced
 none multiple pruning events Approx. dates: _____
Special Value: specimen heritage/historic wildlife unusual street tree screen shade indigenous protected by gov. agency

TREE HEALTH

Foliage color: normal chlorotic necrotic Epicormics? Y N
Foliage density: normal sparse Leaf size: normal small
Annual shoot growth: excellent average poor Twig Dieback? Y N
Woundwood development: excellent average poor none
Vigor class: excellent average fair poor
Major pests/diseases: _____

Growth obstructions:
 stakes wire/ties signs cables
 curb/pavement guards
 other _____

SITE CONDITIONS

Site Character: residence commercial industrial park open space natural woodland/forest
Landscape type: parkway raised bed container mound lawn shrub border wind break
Irrigation: none adequate inadequate excessive trunk wetted
Recent site disturbance? Y N construction soil disturbance grade change line clearing site clearing
% dripline paved: 0% 10-25% 25-50% 50-75% 75-100% Pavement lifted? Y N
% dripline w/ fill soil: 0% 10-25% 25-50% 50-75% 75-100%
% dripline grade lowered: 0% 10-25% 25-50% 50-75% 75-100%
Soil problems: drainage shallow compacted droughty saline alkaline acidic small volume disease center history of fail
 clay expansive slope _____° aspect: _____
Obstructions: lights signage line-of-sight view overhead lines underground utilities traffic adjacent veg. _____
Exposure to wind: single tree below canopy above canopy recently exposed windward, canopy edge area prone to windthrow
Prevailing wind direction: _____ Occurrence of snow/ice storms never seldom regularly

TARGET

Use Under Tree: building parking traffic pedestrian recreation landscape hardscape small features utility lines
Can target be moved? Y N Can use be restricted? Y N
Occupancy: occasional use intermittent use frequent use constant use

The International Society of Arboriculture assumes no responsibility for conclusions or recommendations derived from use of this form.

TREE DEFECTS

ROOT DEFECTS:

Suspect root rot: Y N Mushroom/conk/bracket present: Y N ID: _____

Exposed roots: severe moderate low Undermined: severe moderate low

Root pruned: _____ distance from trunk Root area affected: _____% Buttress wounded: Y N When: _____

Restricted root area: severe moderate low Potential for root failure: severe moderate low

LEAN: _____ deg. from vertical natural unnatural self-corrected Soil heaving: Y N

Decay in plane of lean: Y N Roots broken Y N Soil cracking: Y N

Compounding factors: _____ Lean severity: severe moderate low

CROWN DEFECTS: Indicate presence of individual defects and rate their severity (s = severe, m = moderate, l = low)

| DEFECT | ROOT CROWN | TRUNK | SCAFFOLDS | BRANCHES |
|-------------------------|------------|-------|-----------|----------|
| Poor taper | | | | |
| Bow, sweep | | | | |
| Codominants/forks | | | | |
| Multiple attachments | | | | |
| Included bark | | | | |
| Excessive end weight | | | | |
| Cracks/splits | | | | |
| Hangers | | | | |
| Girdling | | | | |
| Wounds/seam | | | | |
| Decay | | | | |
| Cavity | | | | |
| Conks/mushrooms/bracket | | | | |
| Bleeding/sap flow | | | | |
| Loose/cracked bark | | | | |
| Nesting hole/bee hive | | | | |
| Deadwood/stubs | | | | |
| Borers/termites/ants | | | | |
| Cankers/galls/buris | | | | |
| Previous failure | | | | |

HAZARD RATING

Tree part most likely to fail: _____

Failure potential: 1 - low; 2 - medium; 3 - high; 4 - severe

Inspection period: _____ annual _____ biannual _____ other _____

Size of part: 1 - <6" (15 cm); 2 - 6-18" (15-45 cm);
3 - 18-30" (45-75 cm); 4 - >30" (75 cm)

Failure Potential + Size of Part + Target Rating = Hazard Rating

Target rating: 1 - occasional use; 2 intermittent use;
3 - frequent use; 4 - constant use

_____ + _____ + _____ = _____

HAZARD ABATEMENT

Prune: remove defective part reduce end weight crown clean thin raise canopy crown reduce restructure shape

Cable/Brace: _____ Inspect further: root crown decay aerial monitor

Remove tree: Y N Replace? Y N Move target: Y N Other: _____

Effect on adjacent trees: none evaluate

Notification: owner manager governing agency Date: _____

COMMENTS



Form ID Number _____

INTERNATIONAL TREE FAILURE DATABASE - REPORT FORM

*REQUIRED FIELD

- 1** General Tree Info
- 2** Failure Type
- 3** Failure Specifics
- 4** Structural Defects
- 5** Decay or Injury
- 6** Maintenance History
- 7** Tree Failure Details
- 8** Weather Conditions
- 9** Comments & Save

1 Tree Genus* _____ Species* _____
 Cultivar _____ Country* _____
 State/Province* _____ County _____
 DBH* _____ in/cm Height _____ ft/m Age _____ years
 Tree/Site Ownership: Private Utility Other or unknown
 Fed./Nat.: (NFS BIA BLM DOD NPS)
 State/Province County Municipal
 Address/Site name _____
 GPS: Latitude _____ Longitude _____ (NAD83)

2 FAILURE TYPE* (select one)

TRUNK FAILURE

BRANCH FAILURE

ROOT FAILURE

3 Trunk Failure Specifics
 Height of failure above grade* _____ ft/m
 Dia. at break (inside bark)* _____ in/cm

4 Defects Associated with Failure
 None
 Unknown
 Failed portion dead
 Decay Canker Species: _____
 Multiple trunks/codominant stems
 Dense Crown Flush cuts
 Topped One-Sided
 Low live crown ratio Included Bark
 Bow Crook Sweep/corrected lean
 Uncorrected lean
 Cracks in wood:
 Vertical Horizontal
 Lightning Injury Animal Injury
 Fire Injury Insect Injury
 Mechanical Injury Girdling

5 Location of Decay
 HEARTWOOD
 Avg. sound wood thickness _____ in/cm
 Opening (cavity) at failure? No
 Yes, opening _____ % of trunk circ.
 SAPWOOD
 Avg. depth of rot _____ in/cm
 Circumference rotted _____ %
Type of Decay
 Unknown Brown rot
 Canker rot White rot
 Conks/mushrooms/other signs? No
 Yes Name: _____
 Distance from conk to failure: _____ ft/m

6 Hardware
 None
 Girdling hardware
 Other device
 Cable Intact Failed
 Guying Intact Failed
 Prop Intact Failed
 Brace/bolt Intact Failed

3 Branch Failure Specifics
 Dia. at break (inside bark)* _____ in/cm
 Total length failed branch _____ ft/m
 Break at attachment: Yes No
 If No, distance from the attachment to break: _____ ft/m

4 Defects Associated with Failure
 None Unknown
 Failed portion dead Decay
 Dense Crown
 Heavy lateral limbs/Heavy ends
 Included bark Crook
 Failed portion is an epicormic branch
 Cracks in wood
 Mistletoe or epiphyte
 Mechanical Injury Lightning Injury
 Insect Injury Animal Injury
 Canker/Gall
 Species _____

5 Location of Decay
 HEARTWOOD
 Avg. sound wood thickness _____ in/cm
 Opening (cavity) at failure? No
 Yes, opening _____ % of branch circ.
 SAPWOOD
 Avg. depth of rot _____ in/cm
 Circumference rotted _____ %
Type of Decay
 Unknown Brown rot
 Canker rot White rot
 Conks/mushrooms/other signs? No
 Yes Name: _____
 Distance from conk to failure: _____ ft/m

6 Hardware
 None
 Girdling hardware
 Other device
 Cable Intact Failed
 Guying Intact Failed
 Prop Intact Failed
 Brace/bolt Intact Failed

3 Root Failure Specifics* (select one)
 Roots broken
 Dia. of largest broken root _____ in/cm
 Distance from break to trunk _____ ft/m
 Condition of broken roots:
 Dead, no decay Decayed
 Live, no decay Unknown
 Roots cut/severed (not decayed or broken)
 Dia. of largest broken root at cut _____ in/cm
 Distance from trunk to cut _____ ft/m
 % of roots cut _____
 Root plate lifted out of ground
 Root plate radius _____ ft/m
 Root plate depth _____ in/cm
 Root restricted due to:
 Container Root barrier
 Sidewalk/curb Wall/foundation
 Natural Feature Other
 Distance from trunk to restriction _____ ft/m
 % of root zone restricted _____
 Root collar girdled? Yes No
 % circumference girdled _____

Site/Soils Conditions
 Soil composition: Sand Silt Loam
 Clay Rock/gravel Unknown
 Soil moisture at time of failure: Unknown
 Dry Saturated Moist Flooded
 Restricted rooting depth due to:
 Poor drainage Shallow or layered soil
 High water table Compacted Other
 Other Site Conditions:
 Soil eroded Compaction
 Grade change Well surrounds trunk
 Fill soil against trunk or planted too deep
 Depth of excess soil _____ in/cm

4 Defects associated with failure
 None Unknown
 Fire scar/injury Basal wound
 Low live crown ratio
 Corrected lean (sweep)
 Uncorrected lean Animal Injury
 Cracks in trunk prior to failure
 Surface roots or root collar wounded

5 Location of Decay
 % of roots decayed _____
 Conks/mushrooms/other signs?
 No Yes Name: _____
 Avg. sound wood thickness _____ in/cm
 Type: Unknown Brown rot White rot

6 Surface Treatment Unknown
 Mulch Bare soil Turf
 Ground cover Natural forest litter
 Gravel/rock Pavement Other
Irrigation: Unknown
 Infrequent Frequent Never



7 ADDITIONAL INFORMATION
Tree Condition and Pruning History

| | |
|---|--|
| <p>Were the defects associated with failure visible before the tree failed? <input type="radio"/> Yes <input type="radio"/> No <input type="radio"/> Unknown</p> <p>At time of failure the tree was: <input type="radio"/> Dead <input type="radio"/> Declining <input type="radio"/> Alive</p> <p>Was there construction around this tree? <input type="radio"/> Yes <input type="radio"/> No If Yes, when _____ years ago</p> | <p>PRUNING HISTORY</p> <p><input type="checkbox"/> No pruning <input type="checkbox"/> Cleaned <input type="checkbox"/> Lions-tailed</p> <p><input type="checkbox"/> Thinning: <input type="radio"/> Proper <input type="radio"/> Excessive</p> <p><input type="checkbox"/> Reduction/Directional pruning: <input type="radio"/> Proper <input type="radio"/> Excessive</p> <p><input type="checkbox"/> Crown raised _____ % of height</p> <p><input type="checkbox"/> Topped Diameter of stub at cut _____ in/cm</p> |
|---|--|

Habitat Information

| | | |
|---|--|---|
| <p>Trees recently removed in the vicinity of the failed tree: <input type="radio"/> Yes <input type="radio"/> No</p> <p>History of prior failures at site: <input type="radio"/> Yes <input type="radio"/> No</p> | <p>Setting</p> <p><input type="radio"/> Forest <input type="radio"/> Campground <input type="radio"/> Picnic area <input type="radio"/> Trailhead <input type="radio"/> Other developed forest site <input type="radio"/> Commercial site / Institution <input type="radio"/> Street tree / Median-Urban <input type="radio"/> Road side - Rural <input type="radio"/> Utility right-of-way <input type="radio"/> Yard / Garden <input type="radio"/> Park - Urban <input type="radio"/> Golf course <input type="radio"/> Parking lot <input type="radio"/> Other</p> | <p>Aspect</p> <p><input type="radio"/> N <input type="radio"/> NE <input type="radio"/> E <input type="radio"/> SE <input type="radio"/> S <input type="radio"/> SW <input type="radio"/> W <input type="radio"/> NW <input type="radio"/> Not applicable / Flat</p> <p>Slope</p> <p><input type="radio"/> No slope <input type="radio"/> <5 <input type="radio"/> 5-15 <input type="radio"/> 15-30 <input type="radio"/> 30-45 <input type="radio"/> >45</p> |
|---|--|---|

Date / Time of Failure

Date / Season Unknown

Date of failure (Mo/Day/Yr): _____ **OR** Season of failure:
 Time of failure hour _____ Spring Summer Fall Winter
 A.M. P.M. Unknown Year _____

8 WEATHER AND OTHER FORCES AT TIME OF FAILURE

Unknown Temperature (approx.) _____ °F/°C
 Wind speed (approx.) _____ mph/kph Precipitation: None Rain Snow Ice Unknown

9 CAUSE / RESULT OF TREE FAILURE

Why did this failure occur?

Result of tree failure:
 None (No damage other than the failure described) Property damage Personal injury
 Fire Power outage Removal of this tree Loss of other trees Other damage

Property damage estimate \$ _____ (US) Cleanup costs \$ _____ (US) If personal injury describe below.
 Additional Comments (injury, target, damage, etc.):

Cooperator name _____ Date _____
 Please enter data at: <http://ftcweb.fs.fed.us/natfdb/> ITFD Field Form Revised 12/16/2004



List of Inherent Failure Patterns for Selected Species

Reference Source

Publication by Matheny, Nelda P., James R. Clark. *Evaluation of Hazard Trees in Urban Areas II*. P.O. Box 3129, Champaign, IL 61826, International Society of Arboriculture (ISA), 1994.

To obtain a copy of this document, contact the ISA at: <http://www.isa-arbor.com/home.asp>

International Society of Arboriculture
P.O. Box 3129, Champaign, IL 61826
Email comments & questions to isa@isa-arbor.com

Phone: (217) 355-9411
Fax: (217) 355-9516
www.ag.uiuc.edu/~isa



~ ~This page intentionally left blank~ ~

Best Management Practices

TREE PRUNING (Revised 2008)

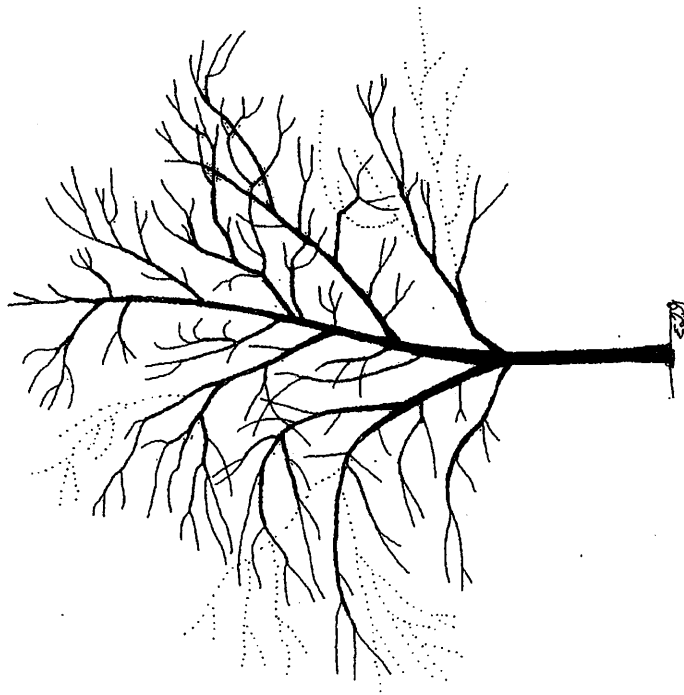

Companion publication to the ANSI A300 Part 1: Tree, Shrub, and Other Woody Plant Maintenance — Standard Practices, Pruning



Best Management Practices

TREE PRUNING (Revised 2008)

Edward F. Gilman and Sharon J. Lilly

Companion publication to the ANSI A300 Part 1: Tree, Shrub, and Other Woody Plant Maintenance — Standard Practices, Pruning

ISBN: 1-881956-31-8

Copyright © 2002 by International Society of Arboriculture
All rights reserved. Printed in the United States of America. Except as permitted
under the United States Copyright Act of 1976, no part of this publication may
be reproduced or distributed in any form or by any means or stored in a
database or retrieval system without the prior written permission of the
International Society of Arboriculture (ISA).

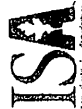

Editorial Coordinators: Peggy Currid and Sharon Lilly

Text and Cover Composition: Kathy Ashmore

Illustrations courtesy of Edward F. Gilman and *Hortiscopia: Illustrated*

Pruning and Planting, Hortiscopia, Inc., Purcellville, VA

Printed by: Printec, Champaign, IL

International Society of Arboriculture

P.O. Box 3129

Champaign, IL 61826-3129

(217) 355-9411

www.isa-arbor.com

isa@isa-arbor.com

1098765

0508-KA-1500

Acknowledgments

Special thanks to Tom Smiley and Jim Clark for taking a great deal of time and effort to thoroughly review this document.

Thanks also go to C. Way Hoyt, Tom Dunlap, Steve Day, Dennis P. Ryan III, Larry Costello, Dane Buell, Bruce Fraedrich, Martin Norris, and Pedro Mendes Castro who made this document better through their timely reviews.

We want to thank the Environmental Horticulture Department at the University of Florida in Gainesville, Florida, for their support of this project. Ed Gilman is a professor in the department that enabled him to take the time to help develop this concept into a final document.

Table of Contents

| | |
|------------------------------------|----|
| Purpose | 1 |
| Introduction | 2 |
| Pruning Objectives | 4 |
| Pruning Methods (Types) | 6 |
| Branch Attachment | 18 |
| Pruning Cuts | 21 |
| How Much to Prune | 25 |
| When to Prune | 26 |
| Tools | 28 |
| Pruning Specifications | 29 |
| Glossary | 32 |
| Other Sources of Information | 36 |
| About the Authors | 37 |

Purpose

Professionals in the field of arboriculture established a committee to develop standards for tree maintenance designed to provide a more uniform level of service and to help ensure public safety. This committee, working under the auspices of the American National Standards Institute (ANSI), developed standards for pruning, fertilization, support systems, and other aspects of tree care. *ANSI A300, The American National Standard for Tree Care Operations – Tree, Shrub, and Other Woody Plant Maintenance – Standard Practices* was written to provide minimal performance standards for use in writing maintenance specifications.

The International Society of Arboriculture (ISA) has developed companion publications known as Best Management Practices to aid in the interpretation and implementation of ANSI A300 standards. These publications are intended as guides for practicing arborists, tree workers, their supervisors, and the people who employ their services.

Because trees are unique living organisms, not all practices can be applied to all trees. It is important that contracts and specifications developed using these guidelines and the ANSI A300 standards are written or reviewed by a knowledgeable arborist. Departures from the standards should be made with careful consideration of the objectives and with supporting rationale.

Best Management Practices: Tree Pruning is the companion publication to *ANSI A300 Part 1 – Tree, Shrub, and Other Woody Plant Maintenance – Standard Practices, Pruning*.

Introduction

This document addresses the question "How do I ensure that my pruning meets industry standards and customer expectations while causing minimal harm to the tree?" It provides reasons why pruning is undertaken, explains pruning types and amounts, provides background on pruning cuts, reviews sample specifications, and comments on timing of these operations. Experience and observation teach the truth in Alex Shigo's observation: "Pruning is one of the best things an arborist can do for a tree but one of the worst things we can do to a tree." Pruning is a double-edged sword, either helping or hurting—depending on where, when, how, and why it is applied.

When pruning is properly executed, a variety of benefits are derived. Benefits include reduced risk of branch and stem breakage, better clearance for vehicles and pedestrians, improved health and appearance, enhanced view, and increased flowering. When improperly performed, pruning can harm the tree's health, stability, and appearance. Several consequences occur when pruning is not performed at all (Figure 1). These consequences include development of low limbs; weak, codominant stems; defects such as included bark; and accumulation of dead branches. Formation of codominant stems and defects such as included bark can lead to increased risk of breakage.

One of the most common defects in planted trees is formation of large, low limbs. They could overextend and break, or they may droop under their own weight and have to be removed later, leaving a large pruning wound. Removal of large branches and those more than about half the trunk diameter is more likely to initiate decay than removal of smaller branches. Therefore, measures should be taken to minimize occurrence of this defect.

On mature trees, live branch removal is less desirable than it is on young trees, but sometimes it is necessary. However, cleaning the crown by removing dead, diseased, or broken branches is a highly recommended practice on mature trees. Because reduction cuts can initiate problems, perform crown reduction only after other options have been considered. Do not remove small interior branches because doing so adversely affects tree structure and can increase failure potential. Trees planted for use as shade trees should not be topped or rounded-over with heading cuts because this practice creates weak structure, exposes wood to infection, can initiate cracks and decay, and looks terrible. Topping also has been shown to increase risk of failure. Reaction zones can reduce available stored energy reserves, making such reserves less available for tree growth and defense.

It is essential first to evaluate the tree and the customer's needs to determine which objectives should be accomplished with pruning. Appropriate pruning meth-

ods can be chosen to meet these objectives. The arborist then enters the tree and makes appropriate pruning cuts for the chosen pruning methods. This decision is based on an understanding of branch attachment and tree biology.

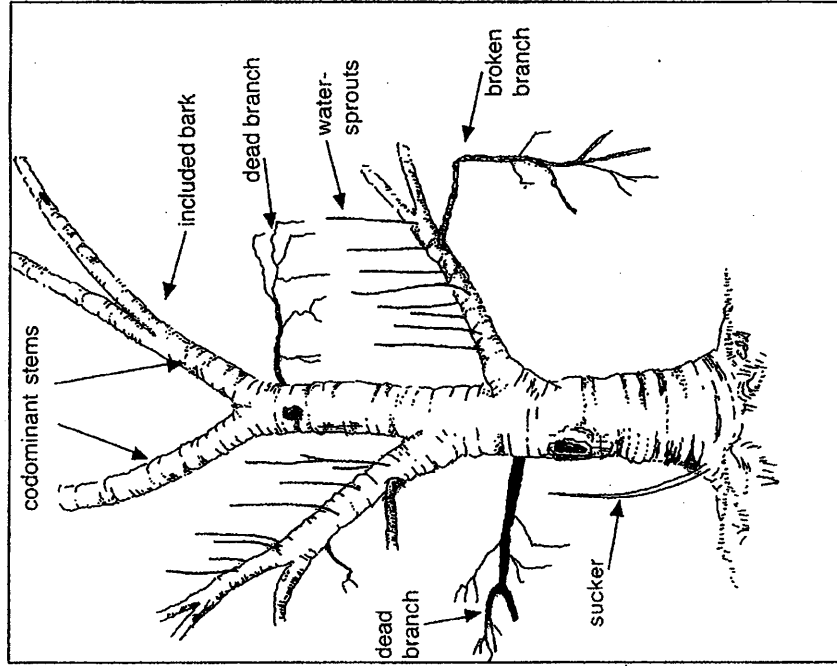

Figure 1. Problems can develop on trees—including codominant stems; included bark; broken and dead branches; suckers and watersprouts; and large, low limbs that require removal.

Pruning Objectives

No tree should be pruned without first establishing clearly defined objectives. Seven main objectives are described (Table 1), along with pruning types that help meet those objectives. These objectives serve as examples and can be expanded or shortened to meet site conditions and customer expectations. Removing the correct stems and branches to accomplish specified objectives is as important as making correct pruning cuts. Even with proper pruning cuts, if the wrong branches — or too many branches — are removed, nothing of merit has been accomplished.

Table 1. Objectives of pruning.

- Reduce risk of failure
- Provide clearance
- Reduce shade and wind resistance
- Maintain health
- Influence flower or fruit production
- Improve a view
- Improve aesthetics

Reduce Risk of Failure

Risk of tree failure can be reduced by establishing a structural pruning program that begins at planting and could carry through the first 25 years or more, depending on the species. This program should be designed to create structurally sound trunk and branch architecture that will sustain the tree for a long period. Some structural pruning can be conducted on older trees as well. Medium-aged and mature trees can be cleaned, thinned, reduced, raised, or restored to manage risk. The choice among these pruning methods depends on the tree and the situation.

Provide Clearance

Growth can be directed away from an object such as a building, security light, or power line by reducing or removing limbs on that side of the tree. However, trees often grow back to fill the void created by pruning. Regular pruning is required to maintain artificial clearance. Shortening or removing low branches can raise the crown. Crown reduction or pollarding helps maintain a tree smaller than it would be without pruning. Utility pruning keeps limbs clear of overhead wires and other utility structures.

Reduce Shade and Wind Resistance

Lawns, ground covers, or shrubs can receive more sunlight when live foliage is removed from the crowns of large overstory trees. The tree's resistance to wind also can be reduced with pruning. Structural pruning, thinning, reduction, and pollarding are used to accomplish this objective.

Maintain Health

Health can be maintained by cleaning the crown, especially in medium-aged and mature trees. Removing dead, diseased, and rubbing branches in the crowns of young trees also is important.

Influence Flower or Fruit Production

Pruning can influence the number and/or size of flowers or fruit. Fruit size can be increased on certain plants, such as peach, by removing some of the developing fruit or flowers. Flower cluster size can be increased on certain species, such as crapemyrtle, by heading. Fruit production can be eliminated by removing flowers or developing fruit.

Improve a View

A view can be enhanced or created by removing live branches at the edge of the crown, at the top of the tree, or on the lower side of the crown. This pruning can include thinning, reducing, pollarding, and raising.

Improve Aesthetics

A tree can be pruned to improve appearance. Cleaning, reducing, thinning, pollarding, and restoring can be used to meet this objective.

Pruning Methods (Types)

Several pruning methods (types) are used in arboriculture to achieve the tree owner's or manager's objective. The four primary pruning methods include cleaning, thinning, raising, and reducing. Trees are also pruned to improve structure and for crown restoration. When writing job specifications the diameter range and location of the branches and stems to be removed should always be included.

Pruning to Clean

Cleaning is the selective removal of dead, diseased, detached, cracked, and broken branches. This type of pruning is done to reduce the risk of branches falling from the tree and to reduce the movement of decay, insects, and diseases from dead or dying branches into the rest of the tree. It can be performed on trees of any age but is most common on medium-aged and mature trees. Cleaning is the preferred pruning type for mature trees because it does not remove live branches unnecessarily.

The location of branches to be removed should be specified if the entire crown is not going to be cleaned. The diameter of branches to be removed also should be specified. This usually is done by specifying the smallest branch to remove (for example, "clean branches 1 inch [2.5 cm] in diameter and larger").

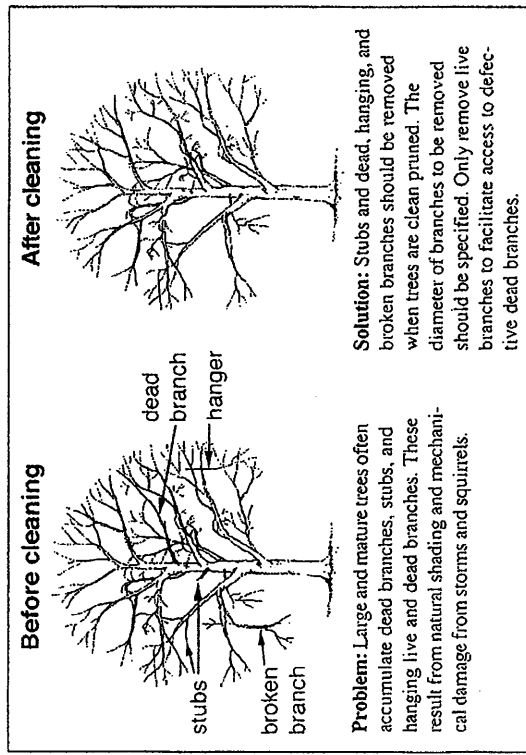

Figure 2. Pruning to clean

Pruning to Thin

Thinning is the selective removal of small live branches to reduce crown density (Figure 3). Because the majority of small branches are at the outside edge of the crown, thinning is focused in that area. Proper thinning retains crown shape and size and should provide an even distribution of foliage throughout the crown.

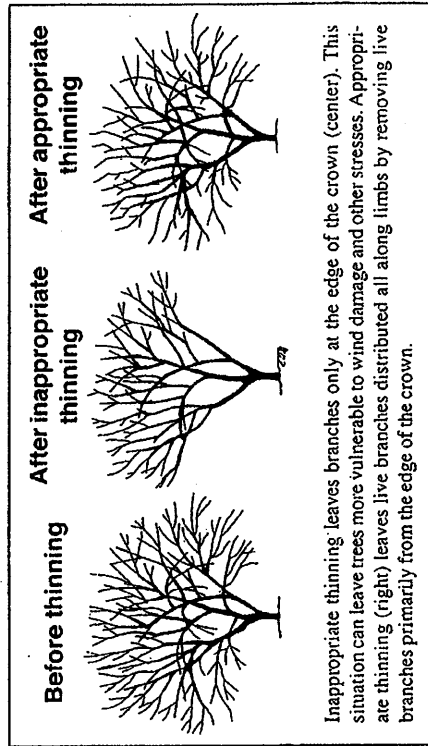

Figure 3. Thinning trees reduces density at the edge of the crown, not on the interior.

Thinning increases sunlight penetration and air movement through the crown. Increased light and air stimulate and maintain interior foliage, which can encourage taper on scaffold branches. Thinning a limb should be considered if cabling will be performed. Thinning also can remove suckers from the base of the tree and some watersprouts on the interior. Excessive removal of watersprouts often produces more watersprouts, so it is not recommended. Vigorous production of watersprouts on interior limbs often is a sign of overthinning, topping, or lion tailing.

Excessive branch removal on the lower two-thirds of a branch or stem (lion tailing) can have adverse effects on the tree and therefore is not an acceptable pruning practice (Figure 3). Lion tailing concentrates foliage at the ends of branches and may result in sunburned bark tissue, watersprouts, cracks in branches, reduced branch taper, increased load on branch unions, and weakened branch structure. Lion tailing also changes the dynamics of the limb and often results in excessive branch breakage.

If the entire crown will not be thinned, the areas to be thinned must be specified. The size range and percentage of foliage to be removed also must be specified—usually in the 10 to 15 percent range—but should not exceed 25 percent of the

foliage, especially on mature trees. Most thinning removes branches 1/2 inch (1.5 cm, small trees) to 2.5 inches (6.5 cm, mature trees) in diameter. If larger branches are removed, large gaps may be created in the crown, or watersprouts can result.

Raising removes indicated branches

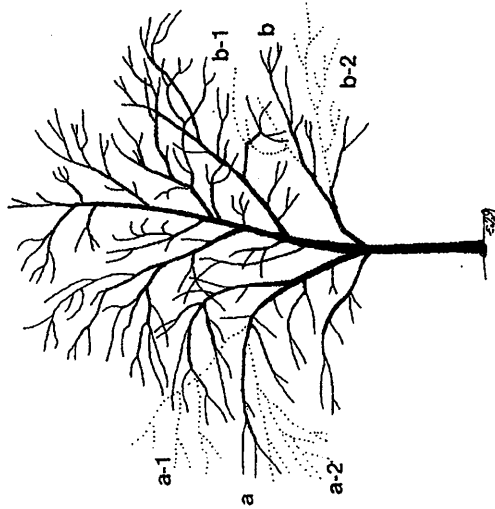

Lower branches *a* and *b* can be removed to raise the crown. However, subordinating branches *a* and *b* by removing upper and lower lateral branches *a-1*, *a-2*, *b-1*, and *b-2* will cause less stress for the tree. Removing *a-2* and *b-2* helps raise the crown. Removing *a-1* and *b-1* ensures that the branches will not grow up to become part of the permanent canopy. This consideration is important because left unpruned, these branches are likely to remain vigorous — forming low, codominant stems.

Figure 4. Raising

Pruning to Raise (Elevate, Lift)

Raising is the selective removal of branches to provide vertical clearance. Crown raising shortens or removes lower branches of a tree to provide clearance for buildings, signs, vehicles, pedestrians, and vistas.

Excessive removal of lower limbs can slow development of trunk taper, can cause cracks or decay in the trunk, and concentrates foliage at the top of the tree.

Mature trees could become stressed if large-diameter lower branches are removed. Clearance sometimes can be achieved by shortening some of the low branches rather than removing them to prevent these problems. Live crown ratio should be no less than 50 percent when raising is completed (Figure 4), and more is better. Structural pruning should be considered along with raising.

When raising, the desired clearance should be specified. To differentiate between complete branch removal and shortening, specify the size range of the limbs to remove and their location (for example, “raise 12 feet [3.5 m] above the road by removing downward-growing branches 2 inches [5 cm] in diameter and smaller”).

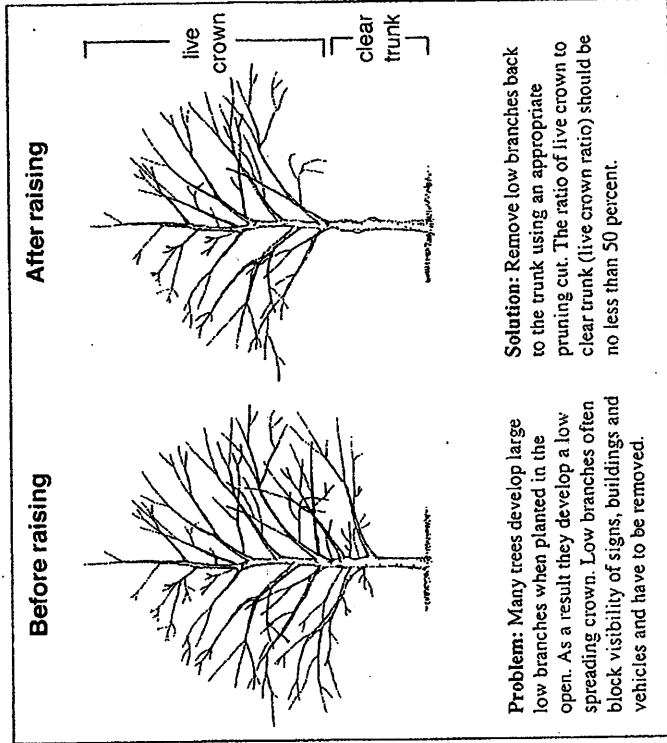

Problem: Many trees develop large low branches when planted in the open. As a result they develop a low spreading crown. Low branches often block visibility of signs, buildings and vehicles and have to be removed.

Solution: Remove low branches back to the trunk using an appropriate pruning cut. The ratio of live crown to clear trunk (live crown ratio) should be no less than 50 percent.

Figure 5. Raising the crown by removing low branches.

Pruning to Reduce (Shape, Drop Crotch)

Reduction is the selective removal of branches and stems to decrease the height and/or spread of a tree or shrub (Figure 6). This type of pruning is done to minimize risk of failure, to reduce height or spread, for utility line clearance, to clear vegetation from buildings or other structures, or to improve the appearance of the plant. Portions of the crown, such as individual limbs, can be reduced to balance the canopy, provide clearance, or reduce likelihood of breakage on limbs with defects. Occasionally, the entire crown is reduced. Reducing or thinning should be considered if cabling would be performed. Crown reduction should be accomplished with reduction cuts, not heading cuts.

Not all tree and shrub species can be reduced. Therefore, the species and plant health should be considered before starting work. Old, stressed, or mature trees could decline or become more stressed as a result of this treatment. When a limb on a

After canopy reduction

Remove end branches with reduction cuts

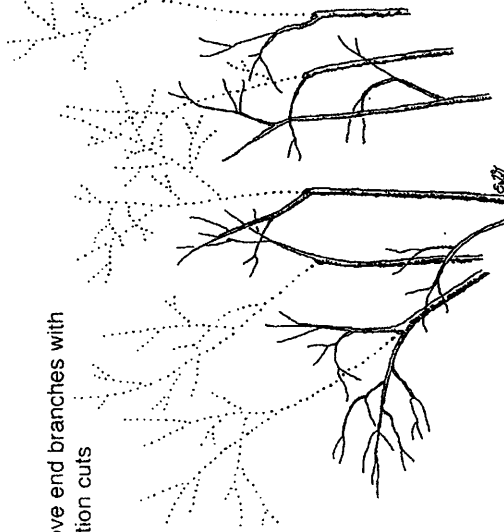

Reduction shortens stems and branches back to live lateral branches. (Removed stem and branch sections are shown as dotted lines.) Notice that live, unpruned branches were left on the edge of the new, smaller canopy and that no heading cuts were used. Properly done, this technique provides a more pleasing, unpruned natural look to the tree or shrub compared to topping or shearing. Compared to topping, less decay is likely to enter the tree following reduction.

Figure 6. Reduction makes a plant, or portion of a plant, smaller in size.

mature tree is cut back to a lateral, no more than one-fourth of its foliage should be removed in routine tree care. More can be removed when pruning to reduce risk, or on a young tree to accomplish particular objectives. Decay is more likely to enter the tree following reduction than following other pruning types.

The clearance distance or percentage of size reduction should be specified. Because making many small cuts or just a few larger-diameter cuts can reduce a tree, it is important also to specify the size range of cuts. Reduction usually should be done on smaller-diameter branches (for example, 1 to 4 inches [2.5 to 10 cm] for trees and 1/4 to 1 inch [0.5 to 2.5 cm] for shrubs).

Structural Pruning

Structural pruning is the removal of live branches and stems to influence the orientation, spacing, growth rate, strength of attachment, and ultimate size of branches and stems. Structural pruning is used on young and medium-aged trees to help engineer a sustainable trunk and branch arrangement. If young trees are pruned to promote good structure, they likely will remain serviceable in the landscape for more years than trees that have not been structurally pruned. Waiting until the tree grows larger makes structural pruning difficult and is more damaging to the tree.

Structural pruning of large-maturing trees such as maples, eucalyptus, and oaks reduces certain defects and spaces main branches along one dominant trunk. Subordination can reduce branches, so they remain smaller than about half the trunk diameter, which helps prevent structural failure later. This pruning type can be summed up in the phrase: subordinate or remove codominant stems. Small-maturing trees can be trained to several trunks or pruned to develop only one, depending on the situation. Small-maturing trees and shrubs are structurally pruned to properly space codominant stems, reduce or remove rubbing limbs, and provide desirable crown configuration. The maximum diameter of the reduction cuts used with this pruning type should be specified.

Multiple prunings over time (for example, 15 to 25 years) usually are required to develop a dominant leader (Table 2). Competing stems and branches are subordinated (reduced in length) or removed (Figure 7). Subordination usually is preferred over removal, especially if the problem stem or stems are larger than half the trunk diameter. Subordination may cause less trunk decay than removal. The offending

Table 2. To establish a dominant leader on a young or medium-aged tree, follow these four steps to encourage a leader to dominate the crown.

1. Choose the one stem that will make the best leader.
2. Identify which stems and branches are competing with this leader.
3. Decide how much to shorten these competing stems.
4. Prevent branches from growing larger than half the trunk diameter by regular pruning.

stem(s) can always be removed later, if necessary. Cleaning and raising are usually done in conjunction with structural pruning.

The lowest permanent limb should be established by shortening vigorous branches below it and any lower branches that grow up into the crown (Figure 7). This procedure may not be possible on a young tree if all branches are below the best position for the lowest permanent limb. The height of the lowest limb is determined by the location and intended function of the tree. For example, the lowest permanent limb on a street tree might be higher than that on an arboretum specimen.

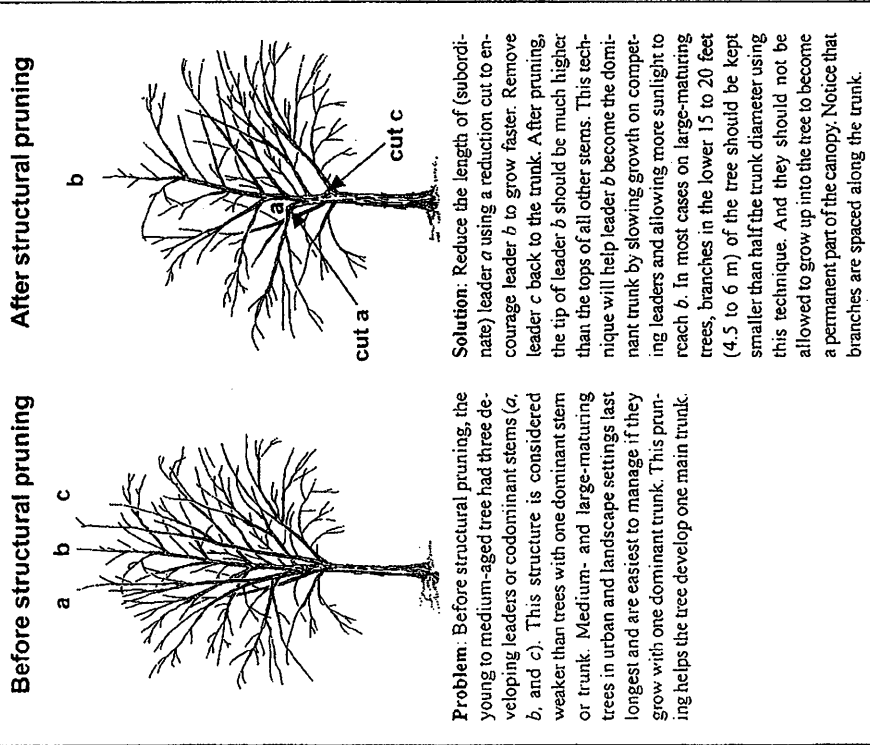

Figure 7. Structural pruning of a small tree.

Select and establish scaffold limbs by subordinating or removing competing stems or branches (Figure 8). Scaffold selection can take 10 to 20 years or more depending on climate, the type of tree, and its location. Scaffold limbs are located above the lowest permanent limb and provide the base on which to build the permanent crown. Scaffold limbs should be free of serious defects such as crooks, included bark, and cracks; should be among the largest on the tree; and should be appropriately spaced. Vertical spacing should be at least 18 inches (46 cm) for large-maturing trees and about 12 inches (30 cm) for smaller trees.

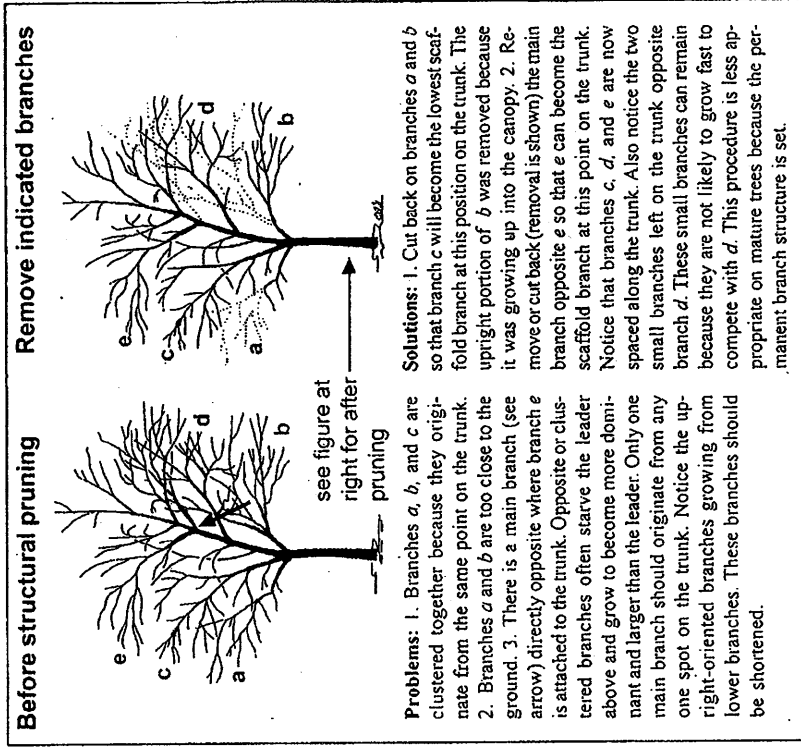

Figure 8. Structural pruning is done to ensure more sustainable growth patterns.

Pruning to Restore

Restoration (remedial pruning) is the selective removal of branches, sprouts, and stubs from trees and shrubs that have been topped, severely headed, vandalized, lion tailed, broken in a storm, or otherwise damaged (Figure 9). The goal of restoration is to improve a tree or shrub's structure, form, or appearance.

On trees with many sprouts originating at the ends of branch stubs, one to three sprouts are selected to become permanent branches and to reform a more natural-appearing crown. To accomplish this objective, consider shortening some sprouts, removing others, and leaving some untouched. Some vigorous sprouts that will remain as branches may need to be shortened to control growth and ensure adequate attachment for the size of the sprout.

Lion-tailed trees can be restored by allowing sprouts to develop along the interior portion of limbs for one to three years depending on size, age, and condition of the tree. Then remove and shorten some of the sprouts along the entire length of the limbs, so they are evenly distributed and spaced apart. Restoration usually requires several prunings over a number of years.

Restoration may require a variety of types of cuts. At times, heading cuts may be preferable to branch removal cuts or reduction cuts to preserve as much of a damaged branch as practical. This is sometimes the case in restoration after storm damage.

Specify the location in the tree (for example, top or interior) and the percentage of sprouts to be removed or reduced. Typically, one-third of the sprouts are removed and one-third are reduced each pruning until adequate branches have developed.

Pollarding

Pollarding is a training system that involves heading the first year followed by annual sprout removal to maintain trees or shrubs at a predetermined size or to maintain a "formal" appearance. Pollarding is not toping. Pollarding historically was used to generate shoots for fuel, shelter, and various products because of the abundance of adventitious sprouts that a tree or shrub produces in this process. The pollarding process should be started on deciduous trees when the tree is young by making heading cuts through stems and branches no more than about three years old.

Table 3. Some species in these genera are known to tolerate pollarding.

| |
|--|
| Ash (<i>Fraxinus</i>) |
| Beech (<i>Fagus</i>) |
| Catalpa (<i>Catalpa</i>) |
| Crape myrtle (<i>Lagerstroemia</i>) |
| Elm (<i>Ulmus</i>) |
| Hawthorn (<i>Crataegus</i>) |
| Horsechestnut (<i>Aesculus</i>) |
| Japanese quince (<i>Chaenomeles</i>) |
| Linden (<i>Tilia</i>) |
| Maple (<i>Acer</i>) |
| Oak (<i>Quercus</i>) |
| Pear (<i>Pyrus</i>) |
| Plane tree (<i>Platanus</i>) |
| Sweetgum (<i>Liquidambar</i>) |

Before restoration

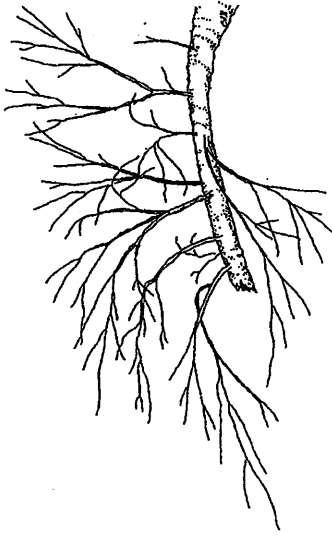

Problem: Many sprouts form from the cut ends of topped or storm-damaged trees. Some sprouts also develop behind the cuts. All are poorly attached to the tree—at least for several years—and can break easily. Notice the eight sprouts that developed from the damaged branch. There are too many sprouts too close together.

After restoration

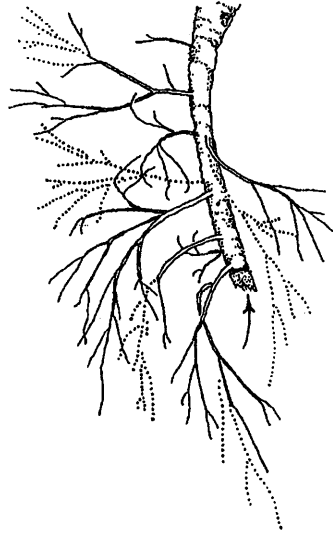

Solution: Begin by removing dead stubs (see arrow), removing some sprouts completely, and shortening others using reduction cuts (indicated by dotted lines). This procedure helps rebuild structure by spacing unpruned sprouts apart so that they can develop into branches. The shortened branches help protect the sprouts that remain.

Figure 9. Restoration attempts to improve structure by removing or reducing sprouts.

Severe heading (topping) through older tissue may kill or start a decline syndrome on some tree species. Table 3 lists several trees that can tolerate pollarding.

Heading cuts are made at strategic locations so that the sprouts from all cuts have access to sunlight. After the initial cuts are made, no additional heading cuts should be necessary. After a few pruning cycles, pollard heads (also called knuckles or knobs) develop, and the tree produces sprouts from these knuckles. Sprouts that grow from knuckles should be removed during the dormant season, taking care not to cut into or below the knobs. The knobs are the key differentiating factor between pollarding and topping. If knobs are damaged or removed in subsequent pruning, the branches react as they would on a topped tree.

Pruning Palms

Palm pruning is the removal of fronds, flowers, fruit, stems, or loose petioles that may create a hazardous condition. Palms also may be pruned for aesthetic reasons to eliminate sprouts and stems or dead fronds and seedpods. Live, healthy fronds should not be removed. If they must be removed, however, avoid removing those that initiate above horizontal (Figure 10). Fronds removed should be severed close to the petiole base without damaging living trunk tissue. Climbing spikes should not be used to climb palms for pruning.

Pruning Conifers

Some pruning types are not appropriate for all conifers. For example, branch spacing and scaffold limb development in conifers usually are not necessary. Thinning on spruces and firs rarely is needed, although in windy area thinning (spiral thinning) could reduce wind resistance and therefore tree failures. Pine growth may be managed by shortening new growth (candles) and removing older needles rather than branch removal. Few conifers respond well to pollarding or reduction.

Palm Pruning

Before pruning

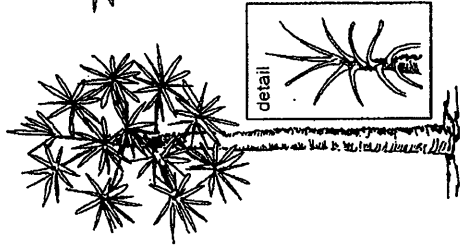

Proper pruning

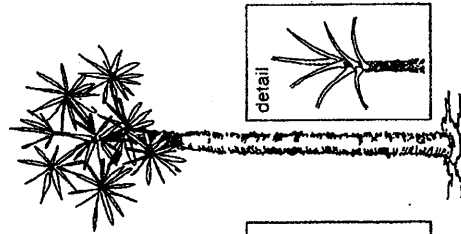

Overpruning

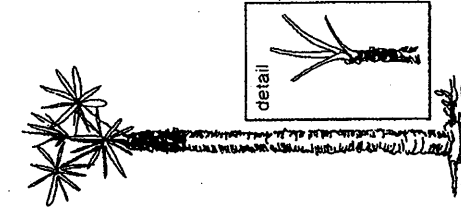

Consider treating nutrient deficiencies along with pruning. Pruning nutrient-deficient palms could cause symptoms to appear in remaining foliage. Remove lower fronds that are chlorotic or dead. There is no biological reason to remove live green fronds on palms. Removing live green fronds is not known to reduce future pruning requirements.

Remove lower fronds that are dead or more than about half chlorotic. It is best for the palm, if green fronds remain intact (if you decide to remove green fronds, the ANSI A300 pruning standard advises never to remove those growing above horizontal.)

Overpruned palms look terrible, have slow growth, and can attract pests. In the detail above, you can see that many upright fronds were removed. Green fronds are almost always removed during this overpruning.

Figure 10. Palm pruning primarily removes dead or chlorotic fronds.

Branch Attachment

When branches remain small relative to the trunk diameter, a swollen collar often develops around the base of the branch. The collar is formed by overlapping and deflected branch and trunk wood (Figure 11). The overlapping wood makes a union strong. Inside the collar on most trees is a unique chemical barrier called the branch protection zone (Figure 11). Its function is to retard the spread of decay organisms into the trunk. If the collar is removed or severely damaged, decay can more easily enter trunk wood and lead to defects.

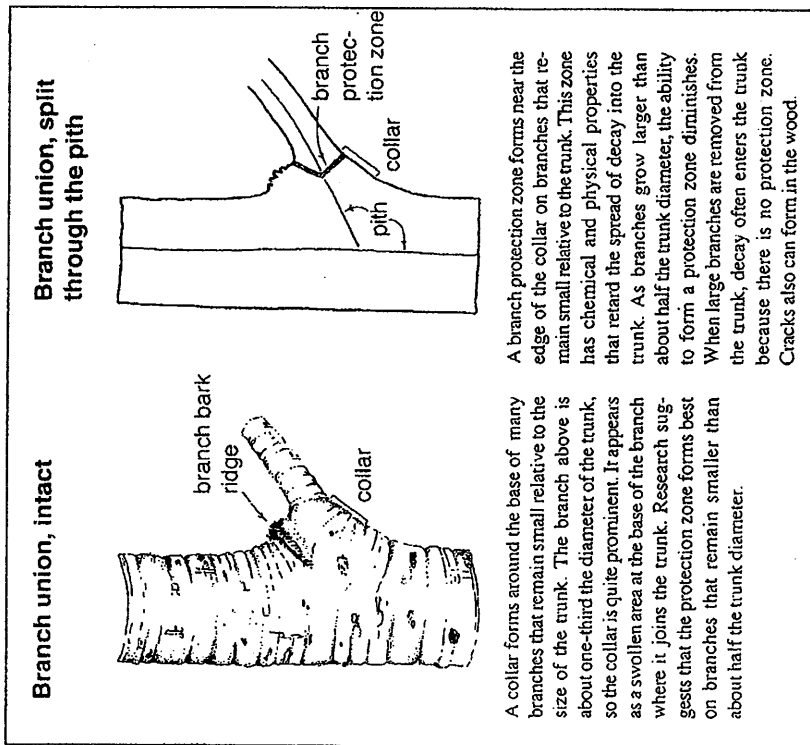

A collar forms around the base of many branches that remain small relative to the size of the trunk. The branch above is about one-third the diameter of the trunk, so the collar is quite prominent. It appears as a swollen area at the base of the branch where it joins the trunk. Research suggests that the protection zone forms best on branches that remain smaller than about half the trunk diameter.

A branch protection zone forms near the edge of the collar on branches that remain small relative to the trunk. This zone has chemical and physical properties that retard the spread of decay into the trunk. As branches grow larger than about half the trunk diameter, the ability to form a protection zone diminishes. When large branches are removed from the trunk, decay often enters the trunk because there is no protection zone. Cracks also can form in the wood.

Figure 11. A collar containing a branch protection zone forms when branches remain small compared to the trunk.

When two stems of approximately equal size (codominant stems, diameter ratios greater than 80 percent) arise from a union, there is little overlapping wood (Figure 12). The result is a weaker union. Decay can enter when one stem is removed because there is no branch protection zone at the base of a codominant stem. The union is even weaker when included bark is part of the condition. Included bark becomes trapped and embedded inside the union as the two stems grow and develop. This condition weakens the union, making the tree prone to failure at that point. There is no traditionally shaped branch bark ridge at the top of the union when included bark is present (Figure 13). Branches and stems with included bark should be removed or shortened on young trees. Removal on large trees may not be a good option because of the potential for decay. Reducing the stem's length or installing a structural support system (see *Best Management Practices: Tree Support Systems*) can minimize the likelihood of the limb failure.

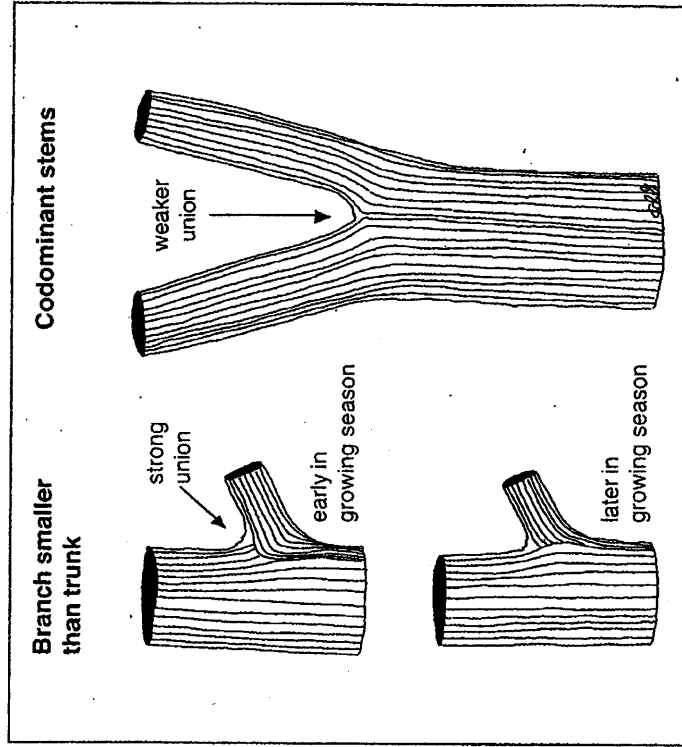

Figure 12. Small branches are well connected to the trunk as a result of overlapping trunk and branch tissue in the union (left). Codominant stems are not as well connected because wood tissue does not overlap in the union (right).

Pruning Cuts

Three general types of cuts are used in arboricultural pruning: branch removal cut (thinning cut), reduction cut, and heading cut. Removal cuts are preferred because they leave the branch protection zone intact.

Branch Removal Cut (Thinning Cut)

When removing a branch at its point of origin on a trunk, stem, or larger branch, make the cut as close to the trunk as possible without cutting into the branch bark ridge or branch collar and without leaving a stub (Figure 13). The cut should leave a smooth surface with no jagged edges or torn bark. If there is no collar, the top of the cut should be located where the top of the branch makes an abrupt upward turn into the union. The correct position varies among trees and branches. Pruning here most closely simulates where branches are shed naturally. The bottom of the cut can be located according to Figure 13. Except on large limbs, the branch protection zone allows for compartmentalization of the wound. If there is a bark inclusion in the union, cut as far down into the union as possible without injuring trunk wood.

Large or heavy branches should be removed using three cuts. The first one undercuts the limb 1 to 2 feet (0.3 to 0.6 m) out from the parent branch or trunk. The undercut reduces the chance of the branch "peeling" or tearing bark as it is removed. The second cut is the top cut, which on small branches should be made directly above the undercut or slightly farther out on the limb than the undercut. The third and final cut is to remove the stub carefully without tearing bark below the cut.

With large trees, branches often need to be lowered rather than dropped to the ground to reduce damage to the tree and objects below the tree. This procedure is done with ropes, cranes, or other equipment. Details on these procedures can be found in *The Art and Science of Practical Rigging* (DVDs and accompanying book published by the International Society of Arboriculture).

When removing a dead branch, the final cut should be made just outside the collar of living tissue (Figure 14). If the collar has grown along a dead branch stub, only the dead stub should be removed. The collar contains live tissue and should not be injured or removed.

Reduction Cut (Cutting to a Lateral, Lateral Cut, Drop-Crotch Cut)

A reduction cut shortens a limb or branch back to a smaller lateral branch or similarly sized limb (Figure 15). Reduction cuts commonly are used in

No collar and included bark

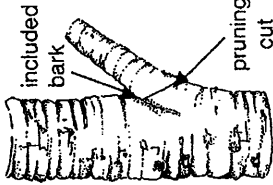

To remove a branch with included bark and no visible collar, cut through the branch as far down into the union as possible without cutting into the trunk. Never cut below the point where the exposed included bark crack ends. Be careful not to injure trunk tissue when making the cut. If doing so is difficult because of the large size of the branch or the shape of the union, cut farther out on the branch than indicated here.

No visible collar

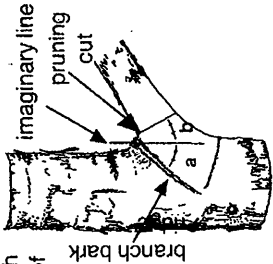

Without a visible collar, construct an imaginary line parallel with the trunk. Estimate angle *a* between the branch bark ridge and the imaginary line. Angle *b* should be greater than or equal to angle *a*. Make your pruning cut where the top of the branch makes an abrupt turn (see pruning cut arrow) into the union. Another guideline is to make the cut to minimize the size of the pruning wound—that is, cut perpendicular to the top of the branch.

Visible collar

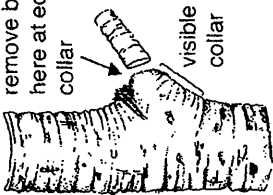

Make the pruning cut just outside the edge of the visible collar. The collar is the swollen area at the base of the branch. If you make the cut here, the branch protection zone remains intact, and decay usually is excluded from the trunk. If the cut is made closer to the trunk, the protection zone is removed, and decay and cracks could occur in the trunk. Do not leave a stub beyond the collar. Leaving a stub could result in the spread of decay into the trunk.

Figure 13. Removing branches from trunks or from parent branches.

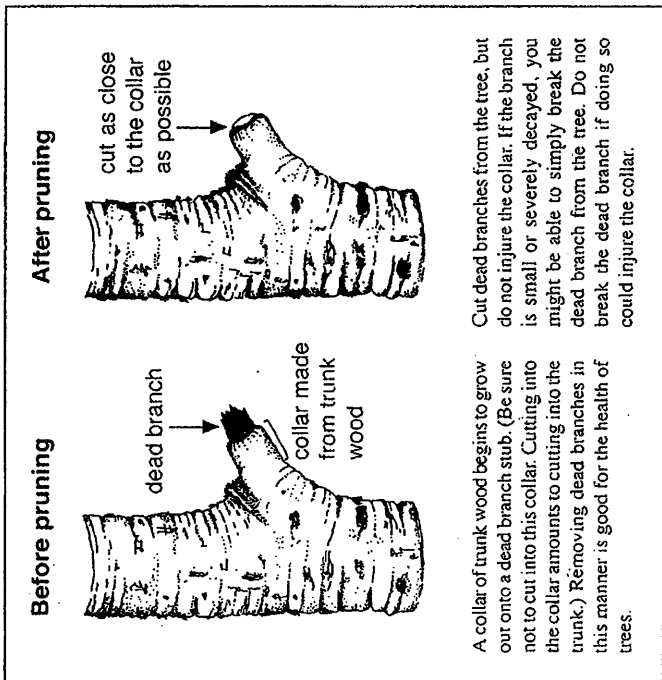

Figure 14. Removing a dead branch should not remove the swollen collar.

structural pruning or when reducing tree size. A stem is cut back to a lateral capable of sustaining the remaining limb and assuming the terminal role. A common rule of thumb is that the remaining lateral branch should be at least one-third to one-half the diameter of the removed portion. At such a size, the lateral branch should be able to produce enough energy to keep the parent branch alive, and enough growth regulator should be present to suppress excessive sprouting on many species. This rule varies with tree species, age, and condition, and with climate. Old, stressed, or mature trees could decline or become more stressed if too much foliage is removed.

When possible, avoid large reduction cuts (more than 2 inches [5 cm] diameter) on permanent scaffold limbs. Avoiding large cuts is less important on limbs that will be removed from the tree later. On permanent branches, it also is important to consider the ability of the lateral branch to sustain the limb. Cutting back to

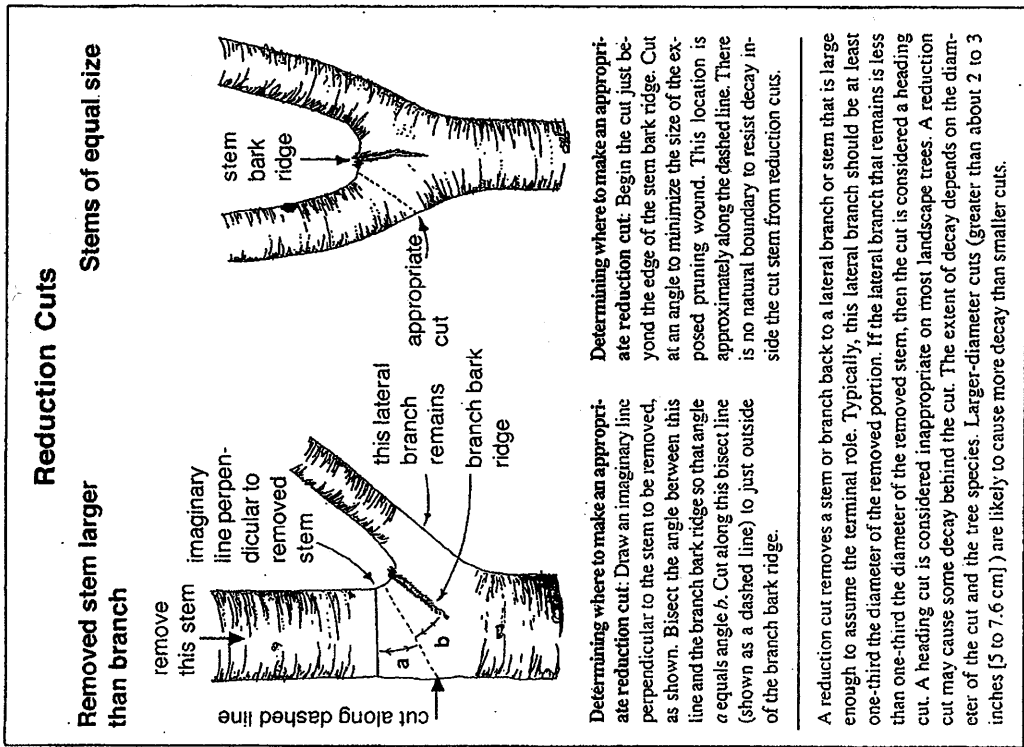

Figure 15. A reduction cut shortens a stem back to a lateral branch.

a lateral that is insufficient in size is much like making a topping or heading cut. Pruning cuts to reduce the length of a limb should bisect the angle between the branch bark ridge and an imaginary line perpendicular to the branch or stem being removed (Figure 15). Cutting *toward* the branch bark ridge reduces the risk of the union splitting out.

Trees do not compartmentalize this type of wound as well as the wound created following a removal cut. The ability of the tree to compartmentalize the wound is a function of the size of the cut, the age of the cut stem or branch, tree vigor or vitality, species, and perhaps the time of year. The smaller the cut and the more vigorous the tree, the better the wound closure and compartmentalization.

Heading Cut

A heading cut (topping cut, lopping cut) is made between branches. This type of cut leaves a stub. These cuts rarely are appropriate on established trees. They can, however, be used on current season's growth to remove old flower heads and developing fruit or to reduce the length of a branch or sprout to improve appearance. Heading cuts are used in the first year of pollarding. Heading should not be used to reduce the height or size of trees in other instances. This practice is called topping and is extremely damaging to shade trees. Shearing (or rounding-over) large-maturing trees also is inappropriate because it causes a profusion of sprouts that grow rapidly into a dense mass of foliage. This practice spoils good tree architecture and can significantly increase maintenance requirements. Shearing is appropriate and commonly practiced on shrubs to maintain size.

Wound Dressing

Wound dressings are treatments applied to pruning cuts or other tree wounds. Traditionally, they were formulated with asphalt-based products in paint or spray form. Wound dressings once were thought to accelerate wound closure and reduce decay. Research shows that these products do not reduce the spread of decay. However, studies have shown beneficial effects of wound dressings in reducing borer attack and oak wilt infection and controlling sprout production and mistletoe. Wound dressings are used primarily for cosmetic purposes, and neither are required nor recommended in most cases. If a dressing must be applied, only a light coating of a nonphytotoxic material should be used.

How Much to Prune

Energy reserves (starch, sugars, and oils) are stored in branches, stems, trunk, and roots. This energy can be preserved by removing the fewest number of live branches necessary to accomplish the desired objective. Excessive branch removal depletes these reserves and reduces the ability of the tree to photosynthesize more energy. There should be a good reason to remove more than 25 percent of the live crown in a single year. Many trees generate adventitious sprouts in response to overpruning as they attempt to replace the stored energy. Live branch pruning, however, is an essential ingredient to forming good structure, so it is a necessary procedure in an urban tree care program.

When to Prune

The best time to prune live branches depends on the desired results. Removal of dying, diseased, broken, rubbing, or dead limbs can be accomplished any time, with little negative effect on the tree.

Growth is maximized and defects are easier to see on deciduous trees if live-branch pruning is done in the winter or before growth resumes in early spring. Pruning when trees are dormant can minimize the risk of pest problems associated with wounding and allows trees to take advantage of the full growing season to close and compartmentalize wounds. Trees with Dutch elm disease should have diseased branches removed as soon as a branch shows flagging.

The timing of pruning can be an important part of a Plant Health Care program. For example, one of the ways to reduce the spread of oak wilt or Dutch elm disease fungus is to prune during the dormant season and avoid pruning susceptible species during the time of the vector beetle flight in areas where disease is a problem.

Plant growth rate can be reduced if live-branch pruning takes place during or soon after the initial growth flush. This is the period when trees have just expended a great deal of stored energy to produce roots, foliage, and early shoot growth, so pruning at this time usually is not recommended because of the potential stresses. Do not prune live branches from stressed trees at this time because they need all their live foliage to help recover.

Flowering can be prevented or enhanced by pruning at the appropriate time of the year. To retain the most flowers on landscape trees that bloom on current season's growth, such as crapemyrtle (*Lagerstroemia* spp.) or linden (*Tilia* spp.), prune these trees in winter, prior to leaf emergence, or in the summer just after bloom. Plants that bloom on last season's wood, such as crabapples (*Malus* spp.) and cherries (*Prunus* spp.), should be pruned just after bloom in order to preserve the flower display. Fruit trees can be pruned during the dormant season to enhance structure and distribute fruiting wood, and they are pruned after bloom to thin fruit.

Certain species of trees, such as maples (*Acer* spp.) and birches (*Betula* spp.), drip sap (bleed) when pruned in the early spring when sap flow is heavy (Table 4). Although unattractive, sap drainage has little negative effect on tree growth or health. Some of the sap dripping can be avoided by pruning in summer or at other times of the year.

Table 4. Trees that often drip sap (bleed) when pruned in late winter or early spring.

| |
|--|
| Avocado (<i>Persea americana</i>) |
| Birch (<i>Betula</i> spp.) |
| Cottonwood (<i>Populus</i> spp.) |
| Elm (<i>Ulmus</i> spp.) |
| Flowering dogwood (<i>Cornus florida</i>) |
| Hackberry (<i>Celtis</i> spp.) |
| Honeylocust (<i>Gleditsia triacanthos</i>) |
| Magnolia (<i>Magnolia</i> spp.) |
| Maple (<i>Acer</i> spp.) |
| Mesquite (<i>Prosopis</i> spp.) |
| Poplar (<i>Populus</i> spp.) |
| Silk-oak (<i>Grevillea robusta</i>) |
| Walnut (<i>Juglans</i> spp.) |
| Willow (<i>Salix</i> spp.) |

Tools

Pruning tools adequate for the size of cuts being made should be selected. Tools should be sharp so as to make clean cuts without jagged edges or stubs. Dull, anvil-type pruning tools, with a blade that cuts to a flat surface, should be avoided because they crush tissue; tools with bypass (scissors-type) blades are preferred. Place the blade side of the pruner toward the tree and squeeze the blade *up* through or *across* the branch. Passing the blade *down* through the branch can cause the union to split.

Equipment and work practices that damage living tissue and bark beyond the scope of the work should be avoided. Climbing spurs are not to be used to climb trees for pruning operations except when limbs are more than a throwline distance apart and there are no other means of climbing the tree, when the bark is thick enough to prevent damage to the cork cambium (for example, on thick-barked species such as mature redwoods), to reach an injured worker, or when removing the entire tree.

Although probably a rare occurrence, the probability of spreading pathogens on pruning tools varies with the particular disease, the plant, the pruning tools used, the environmental conditions, and the timing. Chain saws are difficult, if not impossible, to sterilize during pruning operations. If tools are sterilized, it is important to use a material that will not injure plant tissues or damage tools. Materials commonly used to sterilize tools include bleach (10 percent solution), Lyso!, and automotive antifreeze.

Pruning Specifications

Written specifications are the core of executing good pruning. Without good specifications, each arborist bidding on a pruning job bids on the work he or she thinks should be done, and this decision could vary widely among arborists. Municipalities, condominium and home owner associations, and commercial property managers may benefit most from using specifications. Commercial tree care companies should use ANSI A300 terms when writing pruning specifications on their work orders.

Specifications should include objectives of the pruning, pruning types to be used, size range of branches to remove, percentage of live crown to remove, and location of branches (Table 5). The specifications should state that all work shall be performed according to the ANSI A300 pruning standard and the ANSI Z133.1 safety standard.

Table 5. Minimum pruning specification requirements.

- Clearly state which trees are to be pruned.
- Include a statement that all work shall be performed in accordance with the ANSI A300 pruning standard and the ANSI Z133.1 safety standard.
- Include clearly defined pruning objectives.
- Specify the pruning types to be performed to meet the objectives.
- State the size specifications of the minimum and/or maximum branch size to be removed.
- Specify the maximum amount (expressed as a percentage) of live tissue that can be removed.

Example 1

Specification example to include in a request for bids for pruning medium-aged and mature trees

(The following is only an example and should not be used as is. Develop specifications based on your needs, the objectives of the customer, and the condition and size of the trees to be pruned.)

"Shall" refers to a practice that is mandatory; "should" refers to a practice that is recommended. If a "should" recommendation will not be followed, a written explanation must be provided.

Objectives

Twenty-seven oak trees along Sweetwater Lane from 1600 block to 1800 block shall be pruned to improve structure and reduce the risk of limb failure by

1. cleaning the entire crown of each tree by removing all undesirable branches greater than 1-inch (2.5 cm) diameter.
2. reducing the length of long, horizontal branches by about 5 feet (1.5 m).
3. reducing the length of branches or stems with included bark by 5 to 10 feet (1.5 to 3 m).
4. reducing or thinning by 20 percent any limbs that require cabling.

Procedures

1. Live branches less than 1-inch (2.5 cm) diameter should not be removed from the interior of the crown (some branches may need to be removed to allow the arborist to enter and work in the trees). No live branches greater than 4-inch (10 cm) diameter shall be removed from the tree without authorization from owner or owner's agent.
2. Dead, diseased, or broken branches greater than 1-inch (2.5 cm) diameter (measured at the base of the branch) shall be removed from the canopy of all trees.
3. No more than 20 percent of live foliage shall be removed from any tree.
4. Swollen collars, even if they are quite large, shall remain on the tree following removal of dead branches.
5. Pruning cuts shall be in accordance with ANSI A300 pruning standard, and work shall be performed in accordance with the ANSI Z133.1 safety standard. Pruning shall be in accordance with ISA's *Best Management Practices: Tree Pruning*.

Personnel Qualifications

All work should be performed under the supervision of an ISA Certified Arborist or state licensed arborist.

Example 2

Sample work order for residential tree work

(The following is only an example and should not be used as is. Develop work orders based on your needs, the desires and objectives of the customer, and the condition and size of the trees to be pruned.)

"Shall" refers to a practice that is mandatory; "should" refers to a practice that is recommended. If a "should" recommendation will not be followed, a written explanation must be provided.

Pruning Types to Execute on This Job (Check All That Apply)

structural clean thin raise reduce restore

Objectives and Procedures

1. Reduce potential for failure in large, front-yard white oak (*Quercus alba*) by
 - cleaning (1-inch [2.5 cm] diameter and larger).
 - removing north limb (8-inch [20 cm] diameter) with split crotch and included bark.
2. Raise 12-inch (30 cm) green ash (*Fraxinus pennsylvanica*) in rear to allow under-clearance of 8 feet (2.5 m).
3. Clean (branches greater than 1-inch [2.5 cm] diameter) and thin (remove branches between 1/2- and 1-inch [1.2 to 2.5 cm] diameter only) maple by vegetable garden to allow greater sunlight penetration.

General

No live branches greater than 5-inch (12.5 cm) diameter shall be removed from the tree without authorization from the home owner. No more than 20 percent of live foliage will be removed from the tree. Pruning cuts shall be in accordance with ANSI A300 pruning standard, and work shall be performed in accordance with the ANSI Z133.1 operations standard. Pruning shall be in accordance with ISA's *Best Management Practices: Tree Pruning*.

Glossary

- ANSI A300**—In the United States, industry-developed, national consensus standards of practice for tree care.
- ANSI Z133.1**—In the United States, industry-developed, national consensus safety standards of practice for tree care.
- arboriculture**—Practice and study of the care of trees and other woody plants in the landscape.
- arborist**—Professional who possesses the technical competence gained through experience and related training to provide for or supervise the management of trees and other woody plants in residential, commercial, and public landscapes.
- bark inclusion**—See included bark.
- best management practices**—Best-available, industry-recognized courses of action, in consideration of the benefits and limitations, based on scientific research and current knowledge.
- branch**—A stem arising from a larger stem; a subdominant stem; the pith in true branches has no connection to the parent stem.
- branch bark ridge**—Raised strip of bark at the top of a branch union, where the growth and expansion of the trunk or parent stem and adjoining branch push the bark into a ridge.
- branch collar**—Area where a branch joins another branch or trunk that is created by the overlapping vascular tissues from both the branch and the trunk. Typically enlarged at the base of the branch.
- branch protection zone**—Chemically and physically modified tissue within the trunk or parent branch at the base of a smaller, subordinate branch that retards the spread of discoloration and decay from the subordinate stem into the trunk or parent branch.
- cambium**—Thin layer(s) of meristematic cells that give rise (outward) to the phloem and (inward) to the xylem, increasing stem and root diameter.
- cleaning**—Selective pruning to remove dead, diseased, cracked, and broken branches and foreign objects.
- climbing spurs**—Sharp devices strapped to a climber's lower legs to assist in climbing poles or trees being removed. Also called spikes, gaffs, irons, hooks, or climbers.

closure—The process in a woody plant by which wounded wood grows over a pruning cut or injury.

codominant stem—Forked branches nearly the same diameter (diameter ratios > 80 percent), arising from a common junction and lacking a normal branch union.

compartmentalization—Natural defense process in trees by which chemical and physical boundaries are created that act to limit the spread of disease and decay organisms.

crown—Upper part of a tree, measured from the lowest branch, including all the branches and foliage.

decay—(1) (*noun*) An area of wood that is undergoing decomposition. (2) (*verb*) decomposition of organic tissues by fungi or bacteria.

dominant leader/trunk/stem—The stem that grows much larger than all other stems and branches.

frond—Large, divided leaf structure found in palms and ferns.

good structure/architecture/form—Branch and trunk architecture resulting in a canopy form that resists failure.

heading—Cutting a shoot back to a bud or cutting branches back to buds, stubs, or lateral branches not large enough to assume apical dominance. Cutting an older branch or stem back to a stub in order to meet a structural objective.

included bark—Bark that becomes embedded in a crotch (union) between branch and trunk or between codominant stems. Causes a weak structure.

interior foliage—Typically small-diameter (less than 3 inches [7.6 cm]) branches with foliage on the interior or inner portion of the crown.

kerf—Slit or cut made by a saw in a log. Space created by a saw cut.

lateral—A branch arising from a larger stem or branch.

leader—Primary terminal shoot or trunk of a tree. Large, usually upright stem. A stem that dominates a portion of the crown by suppressing lateral branches.

lion tailing—Poor pruning practice in which an excessive number of branches are thinned from the inside and lower part of specific limbs or a tree crown, leaving mostly terminal foliage. Results in poor branch taper, poor wind load distribution, and a higher risk of branch failure.

live crown ratio—The ratio of the height of the crown containing live foliage to the overall height of the tree.

mature trees—Trees that have reached at least 75 percent of their typical final height and spread.

method—A procedure or process for achieving an objective.

parent branch or stem—A tree trunk or branch from which other branches or shoots grow.

peeling—The removal of dead frond bases without damaging living trunk tissue at the point they make contact with the trunk.

petiole—Stalk or support axis of a leaf.

permanent branches (permanent limbs)—In structural pruning of young trees, branches that will be left in place, often forming the initial scaffold framework of a tree.

photosynthesis—Process in green plants (and in algae and some bacteria) by which light energy is used to form glucose (chemical energy) from water and carbon dioxide.

phytotoxic—Term to describe a compound that is poisonous to plants.

pollarding—Specialty pruning technique in which a tree with a large-maturing form is kept relatively short. Starting on a young tree, internodal cuts are made at a chosen height, resulting in the development of callus knobs at the cut height. Requires regular (usually annual) removal of the sprouts arising from the cuts.

pruning—Removing branches (or occasionally roots) from a tree or other plant using approved practices, to achieve a specified objective.

raising—Selective pruning to provide vertical clearance; also known as lifting.

reaction zone—Natural boundary formed chemically within a tree to separate damaged wood from existing healthy wood. Important in the process of compartmentalization.

reducing—Pruning to decrease height or spread on entire tree or one section; also referred to as reduction or reduction pruning.

reduction cut (drop-crotch cut, lateral cut)—Pruning cut that reduces the length of a branch or stem back to a lateral branch large enough to assume apical dominance—typically at least one-third of the diameter of the cut stem.

removal cut (thinning cut)—Cut that removes a branch at its point of origin. Collar cut.

restoring—The process of pruning to improve the structure, form, and appearance of trees that have been improperly trimmed, vandalized, or damaged.

scaffold limb—A limb or branch that is among the largest diameter on the tree and will remain on the tree perhaps to maturity.

shoot—New stem or branch growth on a plant.

specifications—Detailed plans, requirements, and statements of particular procedures and/or standards used to define and guide work.

stem—Woody structure bearing foliage and buds that gives rise to other stems (branches).

starch—Chain of sugar molecules linked together that serves as a form of energy storage in plants.

structural pruning—Pruning to establish a strong arrangement or system of scaffold branches.

stub—Portion of a branch or stem remaining after a stub cut, branch breakage, or branch death.

subordination—Pruning to reduce the size and ensuing growth of a branch in relation to other branches or leaders.

sucker—Shoot arising from the roots. Contrast with *watersprout*.

thinning—In pruning, the selective removal of live branches to provide light or air penetration through the tree or to lighten the weight of the remaining branches.

throwline—Thin, lightweight cord attached to a throwbag or throwing ball used to set climbing or rigging lines in trees.

topping—Inappropriate pruning technique to reduce tree size. Cutting back a tree to a predetermined crown limit, often at internodes.

trunk—Stem of a tree.

union (crotch)—The junction between stem and branch or between stems.

watersprouts—Upright, epicormic shoots arising from the trunk or branches of a plant above the root graft or soil line. Incorrectly called a sucker. Contrast with *sucker*.

wound—An opening that is created when the bark of a live branch or stem is cut, penetrated, damaged, or removed.

wound dressing—Compound applied to tree wounds or pruning cuts.

Other Sources of Information

Tree Care Industry Association. 2007. *American National Standard for Tree Care Operations—Tree, Shrub, and Other Woody Plant Maintenance—Standard Practices (Pruning)* (A300, Part 1). Tree Care Industry Association, Manchester, NH. 9 pp.

International Society of Arboriculture. 2006. *American National Standard for Arboricultural Operations—Safety Requirements* (Z133.1). International Society of Arboriculture, Champaign, IL.

Costello, L. 1999. *Training Young Trees for Structure and Form* (videocassette). International Society of Arboriculture, Champaign, IL.

Florida Chapter of the International Society of Arboriculture. *Pruning Specifications*. www.floridaisa.org/specifications.php. Florida Chapter, ISA, Gainesville, FL.

Gilman, E.F. 2001. *Hortiscopia: Illustrated Pruning and Planting* (CD-ROM). Hortiscopia, Inc., Purcellville, VA.

Gilman, E.F. 2002. *An Illustrated Guide to Pruning* (2nd ed.). Delmar Publishers, Albany NY. 330 pp.

Harris, R. W., J.R. Clark, and N.P. Matheny. 2004. *Arboriculture: Integrated Management of Landscape Trees, Shrubs, and Vines* (4th ed.). Prentice Hall, Upper Saddle River, NJ.

Shigo, A.L. 1989. *Tree Pruning: A Worldwide Photo Guide*. Shigo and Trees, Associates. Durham, NH.

About the Authors

Edward F. Gilman is professor in the Environmental Horticulture Department at the University of Florida in Gainesville. He has been studying and teaching pruning since he arrived there in 1986. He received a B.S. in forestry and a Ph.D. in plant pathology from Rutgers University. Before joining the faculty at the University of Florida, Ed worked in the tree care and landscape industry for four years.

He continues to conduct tree care research, seminars, and workshops throughout the world. He has authored five books and more than a dozen horticultural software programs. Ed received the ISA author's citation award in 1999 and the American Horticultural Society's Gunlogson Award in 2001 for achievements demonstrating a commitment to the highest standards of horticultural excellence. He has published more than 200 research and trade journal articles on tree and landscape care during the past 20 years.

Sharon J. Lilly is director of educational goods and services for ISA. She received her B.S. and M.S. from The Ohio State University and has more than 30 years of experience as a practicing arborist. Sharon is the author of many books, articles, and training materials in the field of arboriculture.



P.O. Box 3129
Champaign, IL 61826-3129
www.isa-arbor.com



APPENDIX F

ANSI Z133.1-1994
American National Standards Institute Standard
For Tree Care Operations--
Pruning, Trimming, Repairing, Maintaining and Removing Trees,
*and Cutting Brush--**Safety Requirements***

Reference Source

Publication can be obtained from the International Society of Arboriculture (ISA), P. O. Box 3129,
Champaign, IL 61826-3129

Phone: (217) 355-9411
Fax: (217) 355-9516
www.ag.uiuc.edu/~isa

APPENDIX G

ANSI A300-1995
American National Standards Institute Standard
For Tree Care Operations--
Pruning, Trimming, Repairing, Maintaining and Removing Trees,
*and Cutting Brush--**Standard Practices***

Reference Source

Publication can be obtained from the International Society of Arboriculture (ISA), P. O. Box 3129,
Champaign, IL 61826-3129

Phone: (217) 355-9411
Fax: (217) 355-9516
www.ag.uiuc.edu/~isa



~ ~This page intentionally left blank~ ~

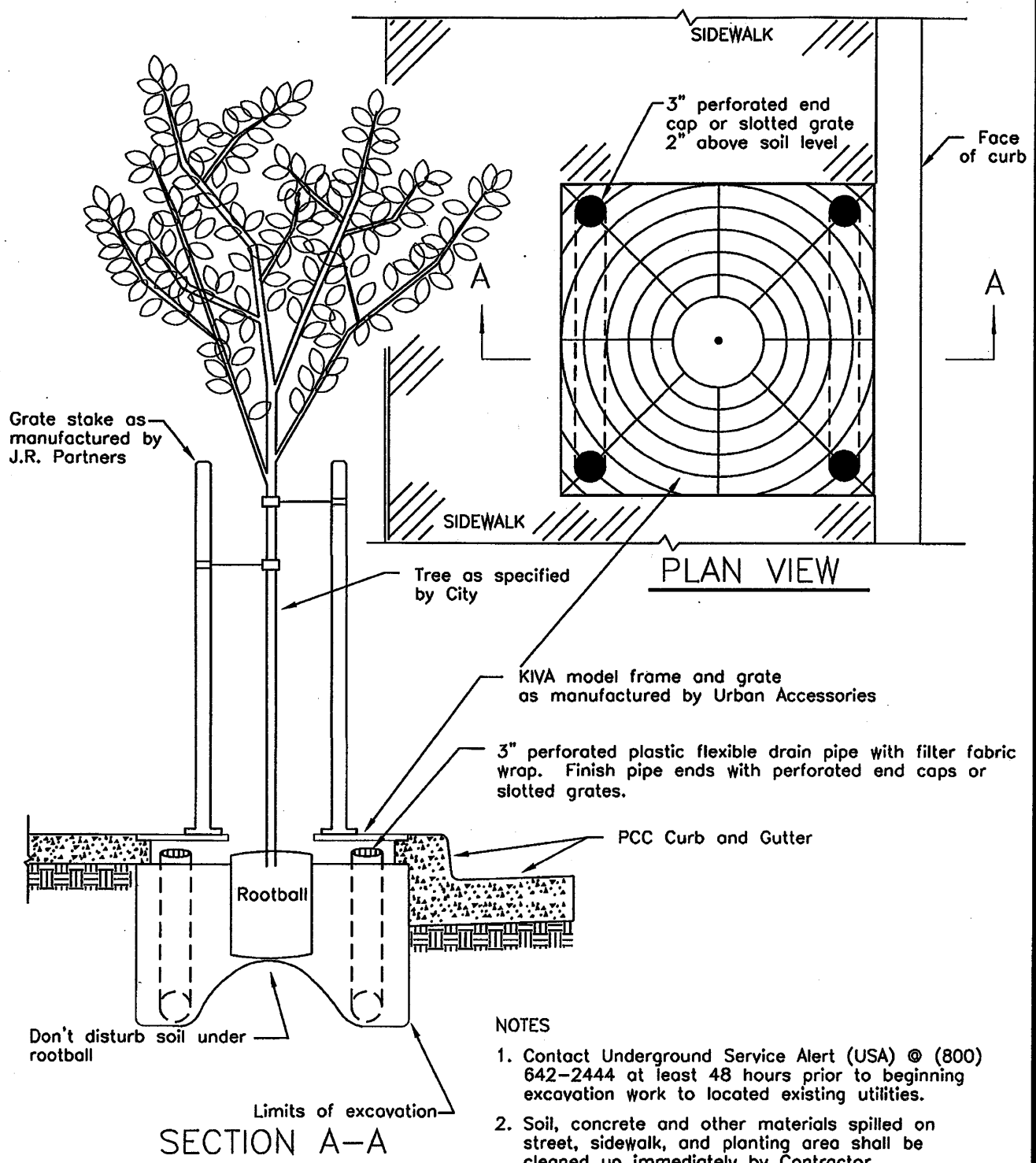

NOTES

1. Contact Underground Service Alert (USA) @ (800) 642-2444 at least 48 hours prior to beginning excavation work to located existing utilities.
2. Soil, concrete and other materials spilled on street, sidewalk, and planting area shall be cleaned up immediately by Contractor.
3. If tree planting is delayed after tree wells are constructed, holes shall be filled and barricades secured to grates.

Backfill with approved loam topsoil around rootball and water at time of planting.

SECTION A-A

| Rev | By | Date |
|-----|-----|----------|
| 0 | SGW | 12/14/92 |
| 1 | JT | 08/14/06 |
| 2 | HN | 03/19/07 |

Tree Well Detail

Approved by:
[Signature]
PE No. 35411
Date 5/14/07

Scale: NTS

City of Palo Alto Standard

Dwg No. 603

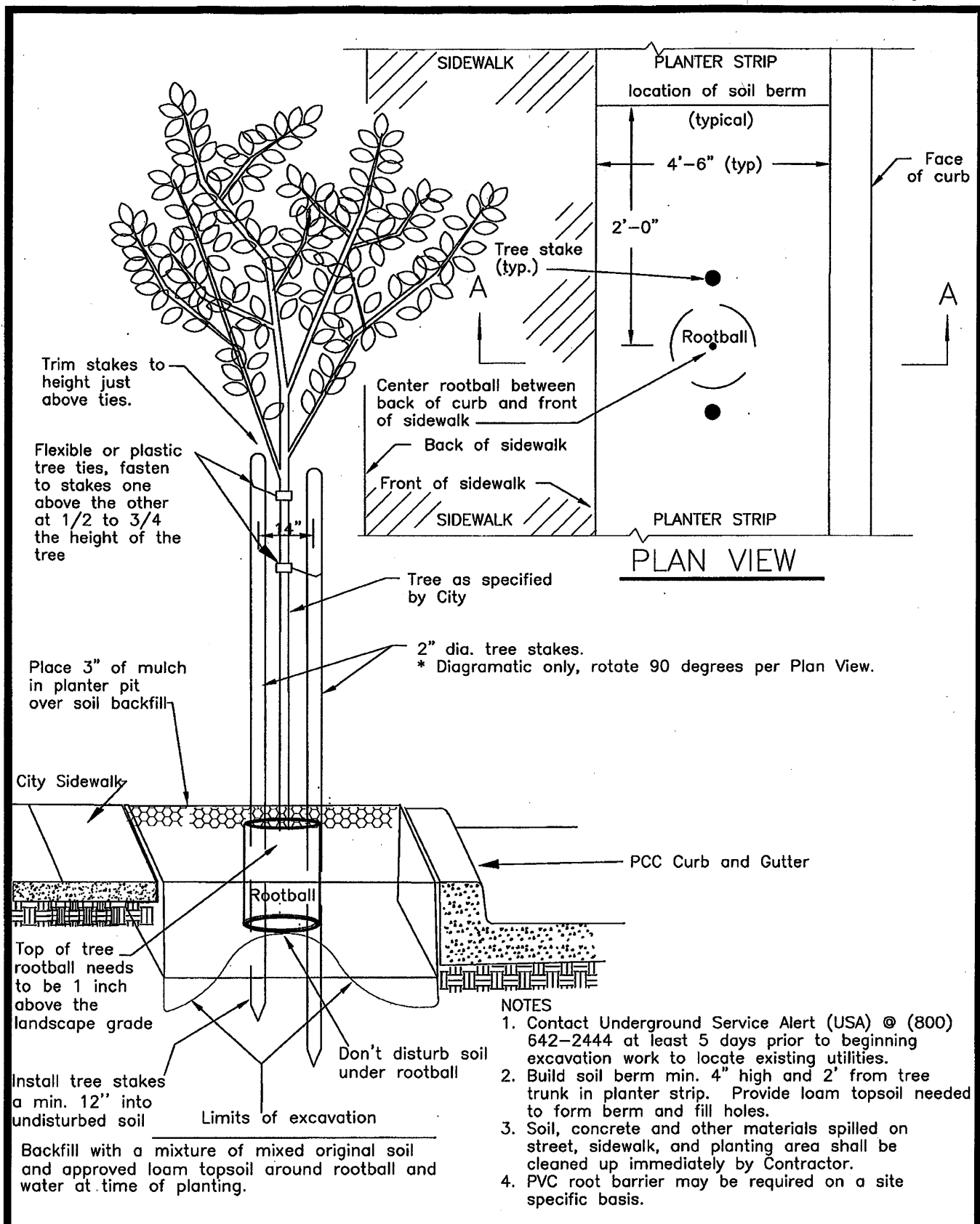

| Rev | By | Date |
|-----|-------|----------|
| 0 | | 12/14/92 |
| 1 | Ron L | 04/15/03 |
| 2 | JT | 08/14/06 |
| 3 | HQN | 03/19/07 |

Scale: NTS

**Tree Detail
Planter Strip**

City of Palo Alto Standard

Approved by:
[Signature]
PE No. 35411
Date 5/14/07

Dwg No. 604

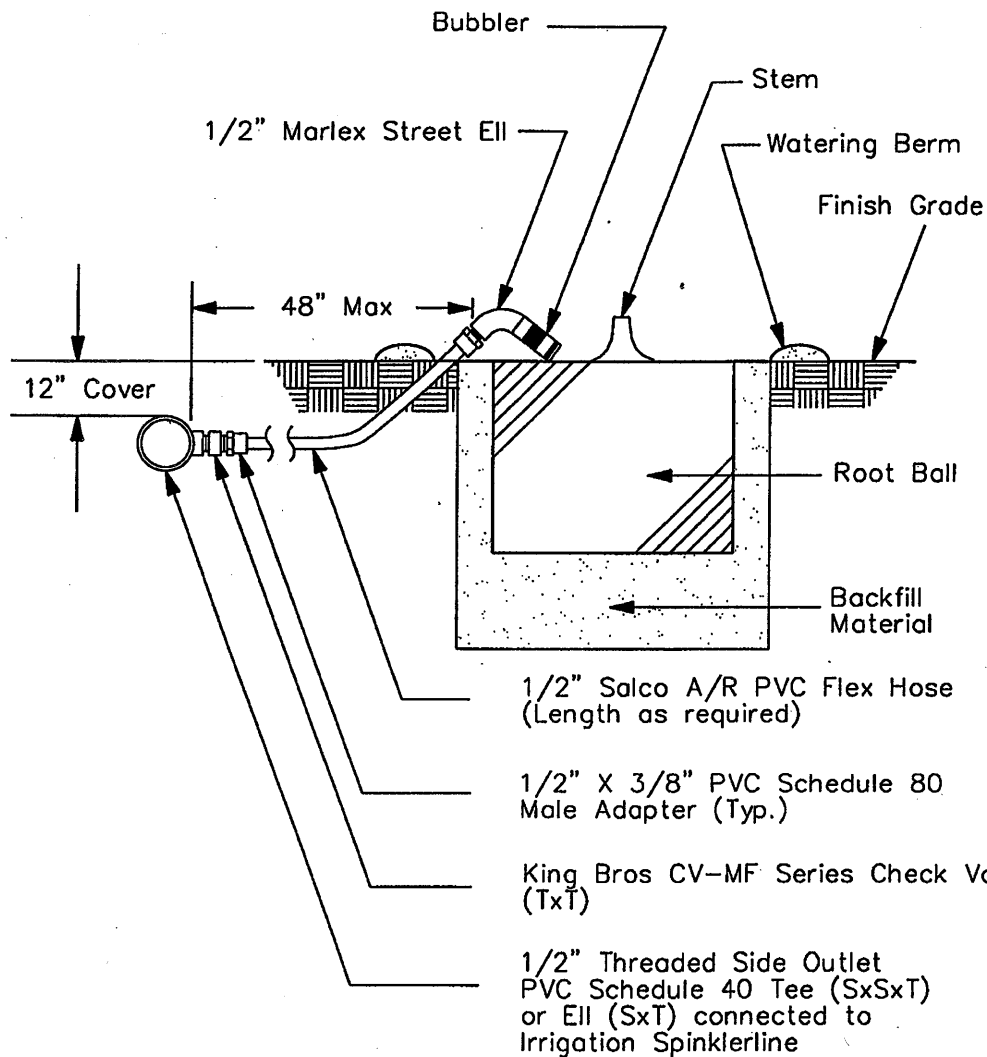

- NOTES:
1. Install Bubbler above root ball. Install bubbler on uphill side of plant at rootball edge where applicable. Allow 6" minimum distance between bubbler and tree.
 2. All tree planting shall use this detail unless otherwise specified.

| Rev | By | Date |
|------------|----|---------|
| 0 | JT | 8/09/06 |
| | | |
| | | |
| | | |
| Scale: NTS | | |

**Irrigation: Bubbler
Installation for Trees in
Ground Cover and other Areas**

City of Palo Alto Standard

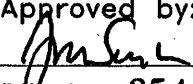
Approved by:

PE No. 35411
Date 5/14/07
Dwg No. 513



~~This page intentionally left blank~~



TREE DISCLOSURE STATEMENT (TDS)

Palo Alto Municipal Code, Chapter 8.10.040, requires disclosure and protection of certain trees located on private and public property, and that they be shown on submitted and approved site plans. A completed *tree disclosure statement* must accompany all permit applications that include exterior work, all demolition or grading permit applications, or other development activity.

PROPERTY ADDRESS: _____

Are there Regulated ¹ trees on or adjacent to the property? YES NO (If no, proceed to Section 4)

[Sections 1- 4 MUST be completed by the applicant. Please circle and/or check where applicable.]

1. Where are the trees? Check those that apply. (Plans must be submitted showing all trees over 4" diameter)

- On the property
- On adjacent property overhanging the project site
- In the City planter strip or right-of-way easement within 30' of property line (Street Trees)*

*Street trees ¹ require special protection by a fenced enclosure, per the attached instructions. Prior to receiving any permit, you must provide an authorized Street Tree Protection Verification form. Contact Public Works Operations at (650) 496-5953 for inspection of type I, II or III fencing (see attached Detail #605) required for all street trees.

2. Are there any Protected ¹ or Designated ¹ Trees? YES (Check where applicable) NO

- Protected Tree (s)
- Designated Tree (s)
- On or overhanging the property

3. Is there activity or grading within the dripline? (radius 10 times the trunk diameter) of these trees? YES NO

*If Yes, a **Tree Preservation Report** must be prepared by an ISA certified arborist and submitted for staff review (see TTM ², Section 6.25). Attach this report to Sheet T-1, 'Tree Protection, its Part of the Plan!', per Site Plan Requirements.*

4. Are the Site Plan Requirements** completed? YES NO

**Protection of Regulated trees during development require the following: (1) Plans must show the measured trunk diameter and canopy dripline; (2) Plans must denote, as a bold dashed line, a fenced enclosure area out to the dripline, per Sheet T-1 and Detail #605 -

<http://www.cityofpaloalto.org/trees/forms.htm> (See also TTM ², Section 2.15 for area to be fenced)

I, the undersigned, agree to the conditions of this disclosure. I understand that knowingly or negligently providing false or misleading information in response to this disclosure requirement constitutes a violation of the Palo Alto Municipal Code Section 8.10.040, which can lead to criminal and/or civil legal action.

Signature: _____ Print: _____ Date: _____
(Prop. Owner or Agent)

FOR STAFF USE:

Protective Fencing

Sections 5-6 must be **completed by staff** for the issuance of any development permit (demolition, grading or building permit).

5. Protected Trees. The specified tree fencing is in place. A written statement is attached verifying that protective fencing is correctly in place around protected and/or designated trees. YES NO
(N/A if there are no protected trees, check here)

6. Street Trees. A signed Public Works Street Tree Protection Verification form is attached. YES NO
(N/A if there are no street trees, check here)

¹ Regulated Trees – a) Street trees – trees on public property; b) Protected trees – Coast Live Oaks or Valley Oaks which are 11.5" in diameter or larger, Coast Redwoods which are 18" in diameter or larger, when measured 54" above natural grade; and Heritage trees are trees designated by City Council; and c) Designated Trees – commercial or non-residential property trees, which are part of an approved landscape plan.

² Palo Alto Tree Technical Manual (TTM) contains instructions for all requirements on this form, available at www.cityofpaloalto.org/trees/technical-manual.html



~ ~This page intentionally left blank~ ~



**PALO ALTO
STREET TREE PROTECTION INSTRUCTIONS
--SECTION 26--**

26-1 GENERAL

- A. Tree protection has three primary functions:
 - 1. To keep the foliage canopy and branching structure clear from contact by equipment, materials and activities;
 - 2. To preserve roots and soil conditions in an intact and non-compacted state and;
 - 3. To identify the Tree Protection Zone (TPZ) in which no soil disturbance is permitted and activities are restricted, unless otherwise approved.
- B. The Tree Protection Zone (TPZ) is a restricted area around the base of the tree with a radius of ten-times the diameter of the tree's trunk or ten feet; whichever is greater, enclosed by approved fencing type.
- C. All types of tree protection shall first be approved by the Public Works Department.

26-2 RELATED WORK

- A. Standard Drawing 605 – Illustration of tree protection types described below.
- B. City of Palo Alto Tree Technical Manual (TTM)
 - 1. Trenching Restriction Zones (TTM, Section 2.20(C))
 - 2. Arborist Reporting Protocol (TTM, Section 6.30)
 - 3. Site Plan Requirements (TTM, Section 6.35)
 - 4. Tree Disclosure Statement (TTM, Appendix I)
- C. Street Tree Verification (STV) of Protection (Form)

26-3 PRODUCTS

- A. Six feet high galvanized chain link fence or approved equal.
- B. Two inch galvanized posts.
- C. Wood, 2” thick
- D. Orange plastic fencing.

26-4 EXECUTION

- A. Type I Tree Protection
 - 1. The fence shall enclose the entire TPZ of the tree(s) to be protected throughout the life of the construction project.
 - 2. In parking areas, if fencing is located on paving or concrete that will not be demolished, then the posts may be supported by an appropriate grade level concrete base, if approved by Public Works Department.
 - 3. All trees to be preserved shall be protected with six (6) foot high chain link fences.



4. Fences are to be mounted on two-inch diameter galvanized steel posts driving into the ground a minimum depth of 2 feet. Spacing between posts shall not exceed 10 feet. Fencing shall extend to the outer branching, unless specifically approved on STV form.
- B. Type II Tree Protection
1. For trees situated within a planting strip, the planting strip and yard side of the TPZ shall be enclosed with the required chain link protective fencing in order to keep the sidewalk and street open for public use.
 2. All trees to be preserved shall be protected with six (6) foot high chain link fences.
 3. Fences are to be mounted on two-inch diameter galvanized steel posts driven into the ground a minimum depth of 2 feet. Spacing between posts shall not exceed 10 feet. Fencing shall extend to the outer branching, unless specifically approved on STV form.
- C. Type III Tree Protection
1. To be used only with approval by the Public Works Department. Trees situated in a tree well or sidewalk planter pit, shall be wrapped with 2-inches of orange plastic fencing from the ground to the first branch and overlaid with 2-inch thick wooden slats bound securely (slats shall not be allowed to dig into the bark).
 2. During installation of the plastic fencing, caution shall be used to avoid damaging any branches. Major limbs may also require plastic fencing as directed by the City Arborist.
- D. 'Warning' sign.
1. A warning sign shall be weather proof and prominently displayed on each fence at 20-foot intervals.
 2. The sign shall be a minimum 8.5-inches x 11-inches and clearly state in half inch tall letters: "WARNING - Tree Protection Zone - This fence shall not be removed and is subject to a fine according to PAMC Section 8.10.110."
- E. Duration.
1. Tree fencing shall be erected before demolition, grading or construction begins and remain in place until final inspection of the project, except for work specifically allowed in the TPZ.
 2. Work or soil disturbance in the TPZ requires approval by the City Arborist. Excavations within the public right of way require a Street Work Permit from the Public Works Department.
- F. All neighbors' trees that overhang the project site shall be protected from impact of any kind.
- G. The applicant shall be responsible for the repair or replacement plus penalty of any publicly owned trees that are damaged during the course of construction, pursuant to Section 8.04.070 of the Palo Alto Municipal Code.
- H. The following tree preservation measures apply to all trees to be retained:
1. No storage of material, topsoil, vehicles or equipment shall be permitted within the TPZ.
 2. The ground under and around the tree canopy area shall not be altered.
 3. Trees to be retained shall be irrigated, aerated and maintained as necessary to ensure survival.

END OF SECTION



 For written specifications associated with illustrations below, see Public Works Specifications Section 31
Detailed specifications are found in the Palo Alto Tree Technical Manual (TTM) (www.cityofpaloalto.org/trees/)

Tree Protection Zone (TPZ) shown in gray (radius of TPZ equals 10-times the diameter of the tree or 10-feet, whichever is greater).
● Restricted activity area -- see Tree Technical Manual Sec 2.15(E).
● Restricted trenching area -- see Tree Technical Manual Sec 2.20(C-D), any proposed trench or form work within TPZ of a protected tree requires approval from Public Works Operations. Call 650-496-5953.

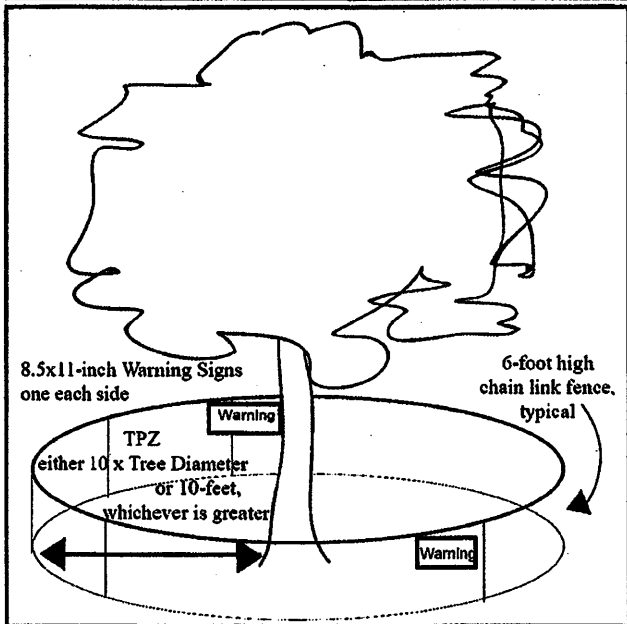

Type I Tree Protection
For all Ordinance Protected and Designated trees, as detailed in the site specific tree preservation report (TPR) prepared by the applicant's project arborist as diagrammed on the plans.

Note: Ordinance Protected & Designated Trees. Issuance of a permit requires applicant's project arborist written verification Type I is installed correctly according to the plans and Tree Preservation Report

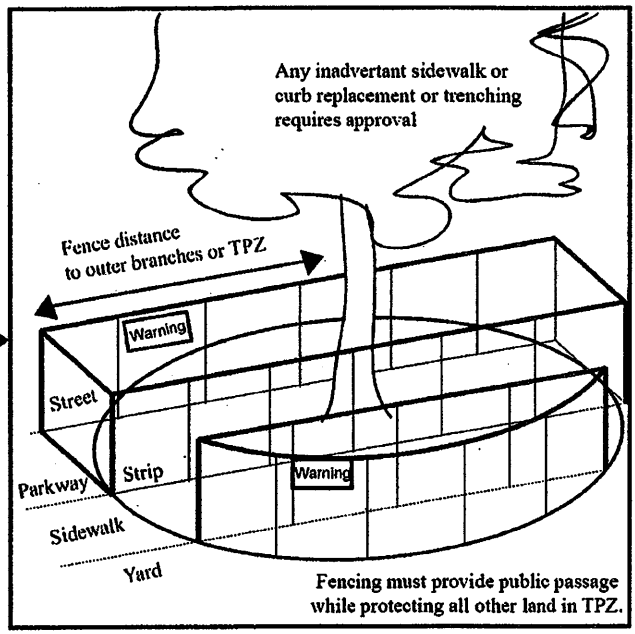

Type II Tree Protection

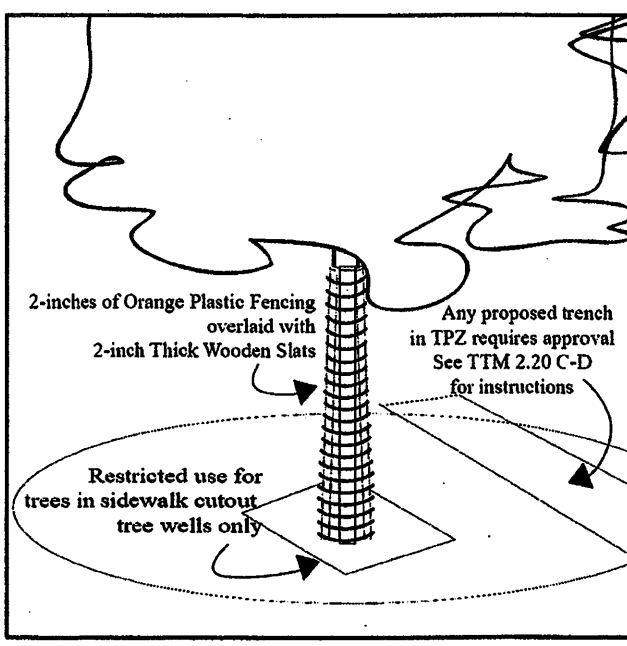

Note: Street Trees. Issuance of a permit requires Public Works Operations inspection and signed approval on the Street Tree Verification (STV) form provided.

Type III Tree Protection
(to be used only with approval of Public Works Operations)

Tree fencing is required and shall be erected before demolition, grading or construction begins.

| Rev | By | Date |
|-----|-----|----------|
| 0 | DWH | 12/14/92 |
| 1 | DD | 08/04/04 |
| 2 | DD | 08/10/06 |

**Tree Protection
During Construction**

City of Palo Alto Standard

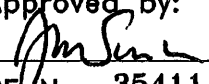
Approved by:

PE No. 35411
Date 5/14/07
Dwg No. 605

Scale: NTS



~ ~This page intentionally left blank~ ~



| | | |
|--|--|--|
| | <p>City of Palo Alto Tree Department Public Works Operations PO Box 10250 Palo Alto, CA 94303 650/496-5953 FAX: 650/852-9289 treeprotection@CityofPaloAlto.org</p> | <p>Verification of Street Tree Protection</p> |
|--|--|--|

Applicant Instructions: Complete upper portion of this form. Mail or FAX this form along with signed Tree Disclosure Statement to Public Works Dept. Public Works Tree Staff will inspect and notify applicant.

| | |
|--|--|
| APPLICATION DATE: | |
| ADDRESS/LOCATION OF STREET TREES TO BE PROTECTED: | |
| APPLICANT'S NAME: | |
| APPLICANT'S ADDRESS: | |
| APPLICANT'S TELEPHONE & FAX NUMBERS: | |

This section to be filled out by City Tree Staff

| | |
|---|--|
| <p>1. The Street Trees at the above address(es) are adequately protected. The type of protection used is:</p> | <p>YES <input type="checkbox"/> NO* <input type="checkbox"/> * If NO, go to #2 below</p> |
| Inspected by: | |
| Date of Inspection: | |

| | |
|--|---|
| <p>2. The Street Trees at the above address are NOT adequately protected. The following modifications are required:</p> | <hr/> <hr/> <hr/> <hr/> <hr/> <hr/> <hr/> <hr/> |
| <p>Indicate how the required modifications were communicated to the applicant.</p> | |

Subsequent Inspection

| | |
|---|--|
| <p>Street trees at above address were found to be adequately protected:</p> | <p>YES <input type="checkbox"/> NO* <input type="checkbox"/> * If NO, indicate in "Notes" below the disposition of case.</p> |
| Inspected by: | |
| Date of Inspection: | |

| | |
|--|--|
| <p>Notes: List City street trees by species, site, condition and type of tree protection installed. Also note if pictures were taken. Use back of sheet if necessary.</p> | |
|--|--|

Return approved sheet to Applicant for demolition or building permit issuance.



~ ~This page intentionally left blank~ ~



PLANNING DIVISION
DEPARTMENT OF PLANNING & COMMUNITY ENVIRONMENT
TREE REMOVAL PROCEDURE

Date: October 2007
To: Tree Removal Permit Applicants
From: Dave Dockter, Managing Arborist, Planning Division
Subject: **PERMIT PROCEDURE FOR REMOVING A REGULATED TREE**

General

The City of Palo Alto procedures for reviewing an application to remove a Regulated Tree requires that the following steps be completed and the information submitted to the Planning Division for review, response and action. Regulated trees include protected trees, publicly owned trees and designated trees.

Protected Trees are defined as: *Coast Live Oak or Valley Oak* trees that are 11.5-inches in diameter or greater; *Coast Redwood* that are 18-inches in diameter when measured at 54-inches above natural grade; and individual trees designated by City Council as *Heritage Trees*. Further definition and details are outlined in the Palo Alto Municipal Code (PAMC) Section 8.10, as well as maintenance requirements and the criteria used in allowing their removal. A Protected Tree removal requires that a permit be issued, as result of a decision by the Director of Planning and Community Environment. A director's decision letter (permit) is issued after to the property owner and is a public record. As for most director's decisions, the required appeal period of 14 days applies before the tree can be removed. See *CITY REVIEW* below for the application instructions, noticing details and process for a Protected Tree Removal Application.

Publicly owned trees are those growing in the right-of-way (i.e. street trees) and on city lands. They are protected and removal or pruning them is prohibited unless approved, per PAMC 8.04. A property owner must contact the Public Works Department at (650) 496-5953 and receive written approval prior to working on a publicly owned tree.

Designated Trees are trees which are located on commercial property or other parcels in which the trees are included as part of the landscape plan of a discretionary City review. Other than maintenance practices, removal of one or more of these trees is considered a minor change to an existing site plan, and requires Planning Department approval before tree removal, as provided for in the Zoning Ordinance, PAMC, Title 18.76.

STEP 1 - APPLICATION FORM & INSTRUCTIONS

Complete a standard Application Form obtained from the Palo Alto Development Center, 285 Hamilton Avenue, Palo Alto, CA 94301. Block #1 of the form must have the Protected Tree Removal box checked, and reflect payment of application fee (see [Fee Schedule](#)). Your application should specify the reason for the request, and how the request meets the findings provided in the tree ordinance, section 8.10.050. The basis of each finding and any other relevant information must be documented by a qualified expert (in most cases, a certified arborist). You may obtain a copy of the Tree Preservation Ordinance or the Palo Alto *Tree Technical Manual* for this and other specific detailed information by browsing the tree programs web pages at <http://www.city.palo-alto.ca.us/trees/>.



PLANNING DIVISION

DEPARTMENT OF PLANNING & COMMUNITY ENVIRONMENT

TREE REMOVAL PROCEDURE

STEP 2 – APPLICANT CHECKLIST_ MAKE AN APPOINTMENT

Please arrange an appointment with Planning Division staff to submit the following material for routing to the city arborist.

Appointments are arranged at (650) 329-2441, and must be in person.

- Completed City of Palo Alto Tree Removal Application
 - Payment of review fee, in the form of a credit card or personal/company check.
 - Provide an Arborist Letter Report (Arborist Name, Certification # and company letterhead) including the following for each tree:
 - o Written details from an ISA Certified Arborist report, describe how the municipal code findings are met, as listed in Palo Alto Municipal Code, section 8.10.050.
 - o Species (common and scientific name)
 - o Size (diameter, height and crown spread)
 - o Condition (foliage, vigor, structural integrity, etc.)
 - o Discussion (is the tree dangerous, imminent hazard, clarify property damage, possible to correct conditions?)
 - o The attached Hazard Evaluation Form may be used to rate a dangerous condition
 - o Life expectancy
 - o Location diagram, structure, street, adjacent trees and photograph.
 - o See also: Tree Reports, Section 6.00, Palo Alto Tree Technical Manual, at http://www.cityofpaloalto.org/planning-community/tree_index.html
-

STEP 3 - CITY REVIEW

Make a Staff Appointment & Process

At the scheduled meeting time, the assigned staff planner will (1) date-stamp the application and tree report; (2) enter the application into the [Accela Permit Manager](#), and assign the next consecutive file number and enter same onto application; (3) document the fee payment, giving the applicant a copy of receipt; (4) route the application material to the Planning Division Arborist.

Review Period

Upon receipt of all required submittal items the Planning Division staff will mail a notice of the pending removal to adjacent property owners as a courtesy comment period of 10 days. After review of the information, the written director's decision will be mailed to the applicant within approximately 10 working days. Staff may require a site visit, contact with the applicant, arborist or additional information if needed. If the tree prognosis is deemed urgent or is a life/safety emergency, the Planning Division Arborist or City Staff shall have the discretion to approve or modify this process as needed, with documentation to follow after the hazard has been brought to a safe level, pursuant to the city Tree Technical Manual, Section 4.00, Hazardous Trees.

Action

Directors Decision. The Director's written response letter constitutes the Protected Tree Removal Permit, and is valid for a period of one year, after which, a new application is required. The response letter may be *approval* (may be with conditions for tree replacement or other requirements), *denial* (with reasons cited and/or mitigating recommendations) or *request for additional information*. No work on the subject tree is permitted until written City approval is granted. Permit Posting. A copy of the approval letter (permit) must be on site when the tree is being removed. The permit letter may be provided to the following places: Applicant, adjacent neighbors, city web site <http://www.city.palo-alto.ca.us/trees/treeremovalpermits>, police and public works departments, and /or specifically requested courtesy copies. Appeal Period. An appeal of this Director's decision by the property owner may be filed in writing with the City Clerk/Planning Division fourteen (14) calendar days after the date of the approval letter (permit), as provided for in PAMC, Chapter 18.78, after which, the tree may be removed.

STEP 4 - CONDITIONS

Frequently, a file will remain open if the approval is conditioned upon required replanting with one or more trees of a predetermined size. To satisfy these director's permit conditions, it is the applicant's responsibility to insure that requirements are implemented, and to schedule a follow-up inspection with the Planning Arborist at (650) 329-2441.



Application Checklist for Heritage Tree Designation by City Council

| STEP # | CHECKLIST OF ITEMS TO INCLUDE |
|--|--|
| <p>1.1. Applicant Consent Letter Addressed to: City Council City of Palo Alto, P.O. Box 10250 Palo Alto, CA 94303</p> | <ul style="list-style-type: none"> <input type="checkbox"/> Property owners' statement of intent requesting that the subject tree(s) be considered as a candidate for Heritage Tree status as outlined in CPA Municipal Code 8.10.090 and the reason you feel it qualifies for such. <input type="checkbox"/> State assurance to the City of the applicant's indefinite commitment to maintain the Heritage Tree specimen according to the standard practice of care and stewardship, and to disclose the same to any future owners of the property. <input type="checkbox"/> Grant consent to include the address and tree location on an inventory list and map that may be utilized by persons interested in viewing the tree. |
| <p>2.1 Photographic Documentation</p> | <ul style="list-style-type: none"> <input type="checkbox"/> Photographs of the tree need not be professional, but must clearly show the tree form and its orientation on the property. They should be suitable for reproduction and viewing by the City Council. <input type="checkbox"/> Creative tips such as long distance, interesting angles, full sun vs. silhouette and a view as seen from the street should be explored. |
| <p>3.1 Arborist Letter Report An ISA Certified Arborist's report must include the following for each tree:</p> | <ul style="list-style-type: none"> <input type="checkbox"/> Arborist Name, Certification # and company letterhead <input type="checkbox"/> Species (a common and scientific name) <input type="checkbox"/> Size (diameter, height and crown spread) <input type="checkbox"/> Condition (foliage, vigor, structural integrity, etc.) <input type="checkbox"/> Life expectancy and brief narrative of the tree <input type="checkbox"/> Location diagram |
| <p>4.1 Value Appraisal</p> | <ul style="list-style-type: none"> <input type="checkbox"/> To determine the tree's contribution to the overall real estate value of the property, a tree appraisal that is prepared by an ISA Certified Arborist shall be included in the submittal. As long as the Heritage Tree remains in good standing on the City Council listing, the property owner will realize benefit of the tree's documented value for use in real estate transactions, IRS property loss claims (due to sudden event/disaster) or other bonafide uses. <input type="checkbox"/> The appraisal will use the most current edition of (1) the 'Guide for Pant Appraisal', published by the Council of Tree and Landscape Appraisers and, (2) the most recent 'Form for Northern California' established by the International Society of Arboriculture. Form for Northern California' established by the International Society of Arboriculture. |
| <p>5.1 City Review.</p> | <ul style="list-style-type: none"> <input type="checkbox"/> Upon receipt of the above information, an evaluation review will be performed by the Department of Public Works and Planning and Community Environment to determine candidate viability. If no other information is needed and the candidate tree is deemed suitable, as outlined in PAMC 8.10.090, the application will be recommended for City Council review and a City Managers Report (CMR) will be prepared. |
| <p>6.1 City Council Action</p> | <ul style="list-style-type: none"> <input type="checkbox"/> The City reserves the privilege of combining a number of Heritage Tree applications before being placed on the City Council agenda for consideration. Notice of this Agenda item will be mailed to the property owner. <input type="checkbox"/> The property owner will receive written response of the Council action to the determination of acceptance or denial. The property owner's Heritage Trees will be entitled to all benefits realized from other Protected Trees, as outlined in PAMC 8.10. Records of the tree will be maintained by the City indefinitely and available for review, and may be updated by the property owner at any time. |



~ ~This page intentionally left blank~ ~



Feedback

EXPLORE

- Government Home
- Departments Home
- Public Works Home
- Urban Forest Home
- Capital Improvement Projects
- Development Process
- Management Plans
- Maintenance Operations
- Regulated Trees
- What You Can Do
- Who We Are
- FAQs

My Palo Alto

Phonebook



Palo Alto's Urban Forest

0 Likes 3 Likes



Welcome to the Urban Forestry Section web page of the Public Works Department. The staff of the Urban Forestry Section is responsible for the maintenance of Palo Alto's public trees and urban forest. The staff reports to the Urban Forester who has overall responsibility for all City of Palo Alto tree concerns and manages the Arborist who is the liaison for the development process private tree concerns, and additional assisting field arborists who schedule, inspect, and administer field work and direct in-house tree maintenance crews. The in-house crews perform pruning, removal of dead and hazardous trees, planting and watering of trees, and emergency tree operations. Under the direction of the Urban Forester, the assisting arborists inspect trees, administer contracts with other tree services companies (such as stump grinding and pruning), line-clear for utilities, and ensure tree protection standards are met and permits are properly approved and enforced.

Please call (650) 496-5953 if you have questions about City-related tree services.

Last Updated: Mar 18, 2015

Contact Us

Public Works Urban Forestry Section

Phone: (650) 496-5953
pwps@cityofpaloalto.org
 P.O. Box 10250
 Palo Alto, CA 94303

Please feel free to contact us if you have any questions or comments about this web page.

Featured Links

- Public Tree Care Permit
- Tree and Stump Removals
- Inspection, Pruning and Removal Requests
- Canopy
- Tree Technical Manual
- Planning Department Urban Canopy Webpage
- Power Line Clearing

Public Works
 3201 East Bayshore Road
 Palo Alto, CA 94301
 T. 650-496-5953
 F. 650-852-9289

Navigate to:
[Archive Website](#) [Services](#)
[Departments](#) [Community Partners](#)
[Doing Business](#) [I Want To...](#)

We're Here To Help
[About Website](#)
[A-Z Index](#)
[Phone Directory](#)

Translate
 Powered by [Google Translate](#)



CITY OF
**PALO
ALTO**

Mon-Thu 7:00-4:30pm
Fri 7:00-3:30pm

After hours, or for 24-hr
emergencies, call 650-
329-2413

General City Information
(650) 329-2100

[Visiting
Government](#)

[Open Data](#)

[Sitemap](#)
[Website Feedback](#)

