



IS POSTED IN ACCORDANCE  
WITH GOVERNMENT CODE SECTION  
54954.2(a) OR SECTION 54956

PUBLIC ART COMMISSION  
**Thursday, October 16, 2014**  
Palo Alto Civic Center  
Council Conference Room  
250 Hamilton Avenue  
**7:00 p.m.**  
**AGENDA**

ROLL CALL

AGENDA CHANGES, REQUESTS, DELETIONS

ORAL COMMUNICATIONS

*(Members of the public are invited to address the commission on any subject not on the agenda. A reasonable time restriction may be imposed at the discretion of the Chair.)*

*Materials related to an item on this agenda submitted to the Public Art Commission after distribution of the agenda packet are available for public inspection in the front office of the Lucie Stern Community Center during normal business hours*

APPROVAL OF MINUTES – September 18, 2014 and September 22, 2014

FINANCIAL REPORT - CIP BUDGET      MAINTENANCE BUDGET

STAFF COMMENTS

ACTION

1. Acquisition of artwork into the Collection– Staff recommends the accession of a monotype by artist Ehren Tool into the city collection. The gift is offered by Paula Kirkeby. (10 minutes)

ATTACHMENT

NON-ACTION

2. 3421 - 3431 Hillview Avenue - Initial review of public art in private development for VMware campus. Presentation by Linda Marie Santiago, Bob Giannini, and Carol Dabb. (20 minutes)

ATTACHMENTS

3. 180 El Camino Real – Informational report on the status of the art selection for Simon Property Group at the Stanford Shopping Center. Presentation by Chandra Cerrito of Chandra Cerrito Art Advisors of the project. (20 minutes)

4. Temporary Public Art – Staff to provide an update on the status of *Aurora*, a temporary public art project on King Plaza and discuss the potential extension of permit. (10 minutes)
5. Public Art Master Plan – Staff to provide an update on the status of the public art master plan process. (10 minutes)
6. Subcommittee Reports:
  - a. Governance
  - b. Innovation
  - c. Outreach
  - d. Ad-Hoc
7. Collection Review- Highlights of the Public Art Collection, discussion led by Chair Kavanaugh (10 minutes)

ANNOUNCEMENTS  
FOR YOUR CALENDAR

Next Meeting: Thursday, November 20,2014



CITY OF  
**PALO  
ALTO**

## City of Palo Alto Staff Report to Public Art Commission

---

**October 16, 2014**

**RE: Agenda Item 1**

**Recommendation:**

Staff recommends that the Public Art Commission accept the donation of the monotype by artist Ehren Tool into the City collection. This generous gift is being offered as a donation by collector and art patron Paula Kirkeby, and facilitated by the Palo Alto Art Center.

**Discussion:**

W. A. Ehren Tool is an artist whose work raises awareness about war. A third-generation war veteran who served as a Marine in Desert Shield and Desert Storm in 1991, Tool began studying drawing when he left the Corps in 1994. In addition to clay vessels decorated with press molds of military medals or images of war, Tool produces monotypes on handmade paper. The paper used for this particular artwork was made of cotton rag and a U.S. Army MultiCam uniform worn by an Infantryman in Afghanistan. The fabric was cut up, beaten into a pulp and formed into sheets of paper.

Drew Cameron, the founder of the San Francisco-based Combat Paper Projects states, “The story of the fiber, the blood, sweat and tears, the months of hardship and brutal violence are held within those old uniforms. The uniforms often become inhabitants of closets or boxes in the attic. Reshaping that association of subordination, of warfare and service, into something collective and beautiful is our inspiration”.

From June 7 – 29, Ehren Tool was the Artist-In-Residence at the Palo Alto Art Center. During his residency, he created hundreds of wheel-thrown ceramic vessels using imagery and objects collected from local veterans and their families. The residency program culminated in the exhibition, Containers of Community: Ehren Tool, featuring hundreds of the ceramic cups and a selection of monotypes. A monotype produced just prior to his residency at Smith Andersen Edition is being offered as a donation to the City’s public art collection.



*Untitled*  
Monotype on handmade paper, 2014  
18 x 24 inches  
Gift of Paula Kirkeby  
ET-05-14

\$550

Tool has exhibited his work at the Oakland Museum of California, the Craft and Folk Art Museum in Los Angeles, the Berkeley Art Center, the Bellevue Arts Museum, the Euphrat Museum of Art in Cupertino, and the de Saisset Museum at Santa Clara University. He received his MFA from the University of California, Berkeley and his BFA from the University of Southern California.



## EHREH TOOL

### BORN

1970 Charleston, South Carolina

### EDUCATION

2005 University of California, Berkeley, MFA

2000 University of Southern California, BFA

1994 United States Marine Corps, Sergeant

### Awards:

*United States Artists Berman Bloch Fellow*, Los Angeles, CA 2010

*Lighton International Artists Exchange Program, Grant*, Kansas City, MO 2010

*Emerging Artist*, National Council on Education for the Ceramic Arts, Phoenix AZ 2009

*The Gorusebeck Family Foundation, Grant*, Stanford CA 2006

*The Harry Lord Ford Award* University of California at Berkeley, 2005

*The J. Ruth Kelsey Merit Travel Award*, University of California at Berkeley 2005

### ART TEACHING EXPERIENCE:

Visiting Lecturer, University of California Berkeley- Berkeley, CA

Art 132 "Approaches to sculpture" (intermediate Ceramics) Summer 2013

Visiting Lecturer, University of California Berkeley- Berkeley, CA

Art 132 "Approaches to sculpture" (intermediate Ceramics) Summer 2012

Visiting Lecturer, University of California Berkeley- Berkeley, CA

Art 132 "Approaches to sculpture" (intermediate Ceramics) Summer 2011

Visiting Lecturer, University of California Berkeley- Berkeley, CA

Art 132 "Approaches to sculpture" (intermediate Ceramics) Summer 2010

Visiting Lecturer, University of California Berkeley- Berkeley, CA

Art 132 "Approaches to sculpture" (intermediate Ceramics) Summer 2009

Visiting Lecturer, University of California Berkeley- Berkeley, CA

Art 14 "The Language of sculpture" (intro Ceramics) Fall 2006- Spring 2007

Visiting Lecturer, California College of the Arts- Oakland, CA

"Beginning wheel throwing" Spring 2007

Visiting Lecturer, University of California Berkeley- Berkeley, CA

Art 14 "The Language of sculpture" (intro Ceramics) Spring 2006

Graduate Student Instructor, University of California Berkeley- Berkeley, CA

ART 8 "Introduction to Visual Thinking" Fall 2004- Spring 2005

Adjunct Faculty, University of Southern California - Los Angeles, CA

"Beginning throwing" (intro Ceramics) Fall 2002

Ceramics Instructional Specialist, Grant Elementary School – Santa Monica District, CA Fall 1999

## SELECTED GROUP and SOLO EXHIBITIONS

- 2013 Local Color with Dirty Canteen, Escondido Arts Partnership Municipal Gallery, Escondido, CA  
Art out of War, Joseph Center for Arts and Culture, Joseph OR  
Finding Home: Artwork by Veterans, Rosenberg Library, City College of San Francisco, San Francisco, CA  
War and Healing, Euphrat Museum of Art, De Anza College, Cupertino, CA  
Clay in the Bay, de Saisset Museum, Santa Clara University, Santa Clara, CA  
Intersecting Paths: Arts & Healing, Hebrew Union College, Los Angeles, CA
- 2012 In War: Schoenherr Gallery, North Central College, Naperville, IL  
Veterans Voices 3: Bridgehead Gallery, Alameda, CA  
Aqit Props: University Art Gallery, CSU Chico, Chico CA  
Veteran Expression, Fe Gallery, Pittsburgh, PA  
Production or Destruction, Craft and Folk Art Museum, Los Angeles, CA  
Yelling Clinic, Berkeley Art Center, Berkeley, CA  
40+ Years of Richard Shaw's Students, Worth Ryder Gallery, UC Berkeley, Berkeley, CA  
Making Mends, Bellevue Arts Museum, Bellevue, WA  
Humble Occupation, Stray Dog hosted by Project Slogan, Aberdeen , Scotland, UK
- 2011 Iraqimemorial.org, EFA Project Space, New York, NY  
Hey! Modern art et pop culture, Halle Saint Pierre, Paris, France  
Ehren Tool, Red Star Studios Gallery, Kansas City, MO  
SuperVision, Dorothy Herger Gallery, Salano Community College, Fairfield, CA  
Faculty Connections, L H Horton Jr. Gallery, Delta College, Stockton, CA
- 2010 200 war stories: Ehren Tool, Bongoüt Showroom, Berlin, Germany  
Criss Crossing, Cal State Pomona, Santa Clara, CA  
DIY: A Revolution in Handicrafts, Society for Contemporary Craft, Pittsburgh, PA  
Art of Transformation, JFK University, Berkeley, CA  
Gestures, Museum of Contemporary Craft, Portland, OR  
Dis/Arming Domesticity, Community Arts Center, Wallingford, PA  
To Die For, Projects Gallery, Philadelphia, PA  
Iraqimemorial.org, Sheppard Fine Arts Gallery, University of Nevada, Reno, NV  
Printmakers Go to War, Swarthmore College Library, Swarthmore, PA
- 2009 War Work, The College of Wooster Art Museum, Wooster, OH  
Pandemic, Overtones, Los Angeles, CA  
Veterans' Voice, K Gallery, Alameda, CA  
Nor Cal Clay II, Santa Clara University, Santa Clara, CA  
War Work, Carleton College Art Gallery, Northfield, MN  
Insights of Life from the Shadows of Death, Red Door Gallery, Oakland, CA  
What the Future May Hold: Artists Consider the Post-Bush World, Santa Fe Clay, Santa Fe NM
- 2008 The Art of War: an anti War Exhibition, John Natsoulas Gallery, Davis, CA  
Veterans' Voice, K Gallery, Alameda, CA

- De-struction*, Taigh Chearsabhagh Museum & Arts Centre, Loch nam Madadh Uibhist a Tuath Innse Gall
- Family Jewels*, Bongoüt Showroom, Berlin, Germany
- Confrontational Ceramics: The Artist as Social Critic*, Westchester Arts Council, White Plains, NY
- Art of Democracy*, Inferno Gallery, Oakland, CA
- Yelling Clinic*, The Compound Gallery, Oakland, CA
- Peace & Politics*, American made Alliance, Philadelphia, PA
- Object(ions)*, Michael Berger Art Gallery, Pittsburgh, PA
- Places in Between*, Diablo Valley College, Diablo, CA
- Gestures of Resistance*, Gray Matters, Dallas, TX
- Molluskkollektiv*, Showroom Bongoüt, Berlin, Germany
- 2007 *Land Ho*, Red House, Venice, CA
- Arts Benicia Auction*, Arts Benicia Gallery, Benicia, CA
- Notion Nanny, Berkeley Art Museum, Berkeley, CA* *Hospitality House Auction*, Hospitality House, San Francisco, CA
- ACCESS: Ehren Tool*, Braunstein/Quay Gallery, San Francisco, CA
- Annual Faculty Exhibition*, UC Berkeley, Berkeley, CA
- 2006 *Global*, Hillel Art Gallery, Los Angeles, CA
- By the Hand*, Bedford Gallery, Walnut Creek, CA
- The Man Box and Beyond*, The Lab, San Francisco, CA
- Annual Faculty Exhibition*, UC Berkeley, Berkeley, CA
- 2005 *Cali Vera*, Oakland Museum of Art, Oakland, CA
- Southern Exposure*, UCLA, Los Angeles, CA
- Cream*, The Arts Benicia, Benicia, CA
- Irreconcilable, Berkeley Art Museum, Berkeley, CA*
- 2004 *\*Please accept this cup*, Chico State, Chico, CA
- 393*, California State Long Beach, Long Beach, CA
- Red Alert*, Berkeley Art Center, Berkeley, CA
- \*Ehren Tool, Associated Students of UC Berkeley, Berkeley, CA*
- Dirt*, UC Berkeley, Berkeley, CA
- 2003 *Annual Free Entry Juried Show*, Southern Exposure, San Francisco, CA
- Cluster Bombs on Black Rock Desert*, Burning Man, Gerlach, NV
- Plus One*, USC, F Space, Los Angeles, CA
- 2002 *Sometimes It's Dark*, Practice Space, Los Angeles, CA
- Annual Faculty Exhibition*, USC, Los Angeles, CA
- To Whom It May Concern*, CCA Wattis Institute for Contemporary Art, San Francisco, CA
- Global Address*, USC, Los Angeles, CA
- 2001 *\*Letter from the President*, Lord Mori Gallery (Happy Lion), Los Angeles, CA
- Genome Project*, California Conference for the Advancement of Ceramic Art, Davis, CA
- 2000 *Another Round*, Brewery Project, Los Angeles, CA
- \*Gun Platform*, Gallery 23, Los Angeles, CA
- 1999 *Y2Klay*, Burbank Community Center, Burbank, CA
- Red Tape*, I-5 Gallery, Los Angeles, CA

1998 *Boxing Match*, University of California Irvine – Irvine, CA  
*Big Sexy*, UC Irvine, Irvine, CA

### SELECTED BIBLIOGRAPHY

- Diehl, Travis. "Pierced by Shards, Ehren Tool: Production or Destruction" *X.TRA*, Los Angeles, CA, Vol. 15, Number 3, Spring 2013
- Ollman, Leah. "War's meaning? His cups runneth over" *Los Angeles Times*, Los Angeles, CA, July 25, 2012
- Dambrot, Shana Nys. "Best Art I Saw All Week: Ceramic Cups That Look Like a Gulf War Army" *LA Weekly*, Los Angeles, CA, July 9, 2012
- Jao, Carren. "The Cups of War" *Hyperallergic*, Los Angeles, CA, June 18, 2012
- Ehren Tool. "Making Mends" at BAM: healing and more *Crosscut.com*, Seattle WA, March 9, 2012.
- Ehren Tool. "Do current events shape your work" *American Craft*, Minneapolis MN, Vol. 71, No. 4, Aug/Sept 2011.
- Thorson, Alice. "America' is Here Now" *The Kansas City Star*, Kansas City MO, May 5th, 2011.
- Gilbert, Lori. "Veteran's cup runneth over" *The Record*, Stockton CA, February 11, 2011.
- Thomas, Mary. *Handicrafts exhibition a response to consumption-driven society*, Pittsburgh Post-Gazette, Pittsburgh, PA February 16, 2011.
- Tool, Ehren. "W.A. Ehren Tool" *Hey!*: n<sup>o</sup>5, Paris, France January 2011.
- Cheng, DeWhitt. "Berserkers" *East Bay Express*: Vol. 31, Issue 45, 19 August, 2009.
- Antiwar survey- Ehren Tool. Tool, Ehren. "W.A. Ehren Tool" *Hey!*: n<sup>o</sup>5, Paris, France January 2011.
- Journal of Aesthetics and Protest* #6. Los Angeles. November 2008.
- Schwartz, Judith. *Confrontational Clay*. London: A&C Black. August 2008.
- "Emerging Artist" *Ceramics Monthly*: , May 2008
- "Ehren Tool", *Mollusk* #5, Berlin: Bongoüt GmbH, Dec 2007
- Whiteside, Amber. "'The Man Box and Beyond' at THE LAB," *Artweek*: Vol. 37, Issue 5, June 2006.
- "Last Chance, SF Chronicle 96 Hrs." *SF Chronicle*: 4 May 2006.
- Kurtz, Katie. "The Man Box and Beyond." *SF Bay Guardian*: Vol. 40, No. 31, 3 May 2006
- Mizota, Sharon. "The Masculine Mystique." *SF Weekly*: Vol. 25, No. 13, 26 April 2006.
- Gopalarathinam, Ranjani. "Awareness Art." *SOMA*: Vol. 19.6, Aug. 2005.
- Ted Purves. *What we want is free*. Albany, NY: State University of New York Press. 2005
- Del Vecchio, Rick. "Vet's reality of war measured by the cup." *San Francisco Chronicle*: 5 Nov. 2004.
- Foss, Paul. "Ehren Tool at Lord Mori, Los Angeles." *Artex*: Spring 2002.

Agenda Item 2

October 16, 2014

To: Public Art Commission, Palo Alto, CA

## VMware Public Art Project

### **Budget:**

VMware's proposed Phase Four development project, comprised of two new buildings, includes the replacement of a building, at the top of the VMware campus, near Hillview Avenue. It is this construction project that triggers the public art requirement. (The other building is exempt from public art as it is part of the Mayfield Development Agreement entitlements). The new HTG building will consist of office space and a new executive briefing center. The estimated construction budget is \$25,000,000.00. The approximate art budget is \$250,000.00, all relevant costs inclusive.

### **Art Consultant:**

VMware has selected Carol A. Dabb, Inc., Art Consultant and Broker, from Los Altos, CA, to assist with the artist and art selection. Carol Dabb has been in business for 30 years and has extensive experience in public art projects.

### **Selection Plan:**

VMware looks forward to the Public Art Commission's suggestions and recommendations leading to a decision for art that will be a positive addition to the environment and Palo Alto's public art program.

VMware anticipates considering several different possible solutions. Artwork preferred would be abstract in design. Based on input from the Public Art Commission, Carol Dabb will present professional artists specializing in large-scale public art. There will not be a public open call to artists. VMware is open to consider all media for the art. VMware is open to consider a variety of artists with different styles and approaches, from creating a single large-scale dramatic sculpture to creating an "environment" consisting of several pieces.

Once VMware narrows the choice to one or two artists, VMware, Form 4 Architecture and Carol Dabb will interview the artists. The selected artist, or artists, will propose a site-specific design to VMware for review. This proposal will include visuals of past works, a color elevational of art in its surroundings, and design visuals for lighting and installation. The artist will provide a maquette of proposed art. Upon VMware's final acceptance of the artist and art design, VMware will apply for Final Review by the Public Art Commission.

**Timeline:**

October 2014

50%, \$6,250.00, Public Art Fund paid to Palo Alto.  
Initial Review with the Public Art Commission

November 2014

Artists are presented to VMware.  
VMware chooses artist to design art for public art.

December 2014/January 2015

Artist/s proposes site-specific design with a comprehensive presentation for VMware approval.

January/February, 2015

Artist and Art Consultant develop the presentation package for the Public Art Commission Final Review.

March 2015

Public Art Commission Final Review  
Upon acceptance of art proposal by the Public Art Commission, final payment, 50%, \$6,250.00, is due to Public Art Fund.

April 2015 – March 2016

Fabrication of art

Summer/Fall 2016

Installation of art

Late 2016

Estimated completion of building construction

**Proposed Location for Art:**

The striking aspect of the site VMware is proposing for public art is its location at the top of the stairs at its main and most important entrance to the 105-acre campus. This stairs' area is approximately 4,800 square feet.

This art placement area will allow the best opportunity for public viewing while driving or walking along Hillview Avenue and into the campus from the main Hillview Avenue entrance. The art will be set upon a "stage", so to speak, at the top of the stairs flanked by the main Hillview Avenue entrance, visitor parking lot, executive building, the new construction building (HTG) with its executive briefing center, and the large open grassy area (Town Square) by the three long lily ponds. It can also be viewed looking back from the main lower cafeteria.

The sculpture will be a major and central focal point for viewers, including employees, visitors, and the public in general. Other locations on the campus would be more private and not as accessible to the public.

Peter Walker (PWP Landscape Architects) and Rich Sharp (Studio 5 Landscape Architects) designed the landscape. Beautiful, distinctive, with an emphasis on nature! The art needs to be aesthetically in harmony with the landscape, the architecture, and culture of VMware.





vmware

PRELIMINARY ART PRESENTATION

3421 Hillview - 3431 Hillview, Palo Alto, California

CAROL A. DABB ART CONSULTANT • FORM4 ARCHITECTURE • STUDIO FIVE LANDSCAPE

VMWARE Phase 4  
Preliminary Art Presentation  
October 16, 2014







# The Campus

CAROL A. DABB ART CONSULTANT • FORM4 ARCHITECTURE • STUDIO FIVE LANDSCAPE

VMWARE Phase 4  
Preliminary Art Presentation  
October 16, 2014

EXISTING AERIAL







# The Campus



CAROL A. DABB ART CONSULTANT • FORM4 ARCHITECTURE • STUDIO FIVE LANDSCAPE

VMWARE Phase 4  
Preliminary Art Presentation  
October 16, 2014







# The Campus

CAROL A. DABB ART CONSULTANT • FORM4 ARCHITECTURE • STUDIO FIVE LANDSCAPE

VMWARE Phase 4  
Preliminary Art Presentation  
October 16, 2014





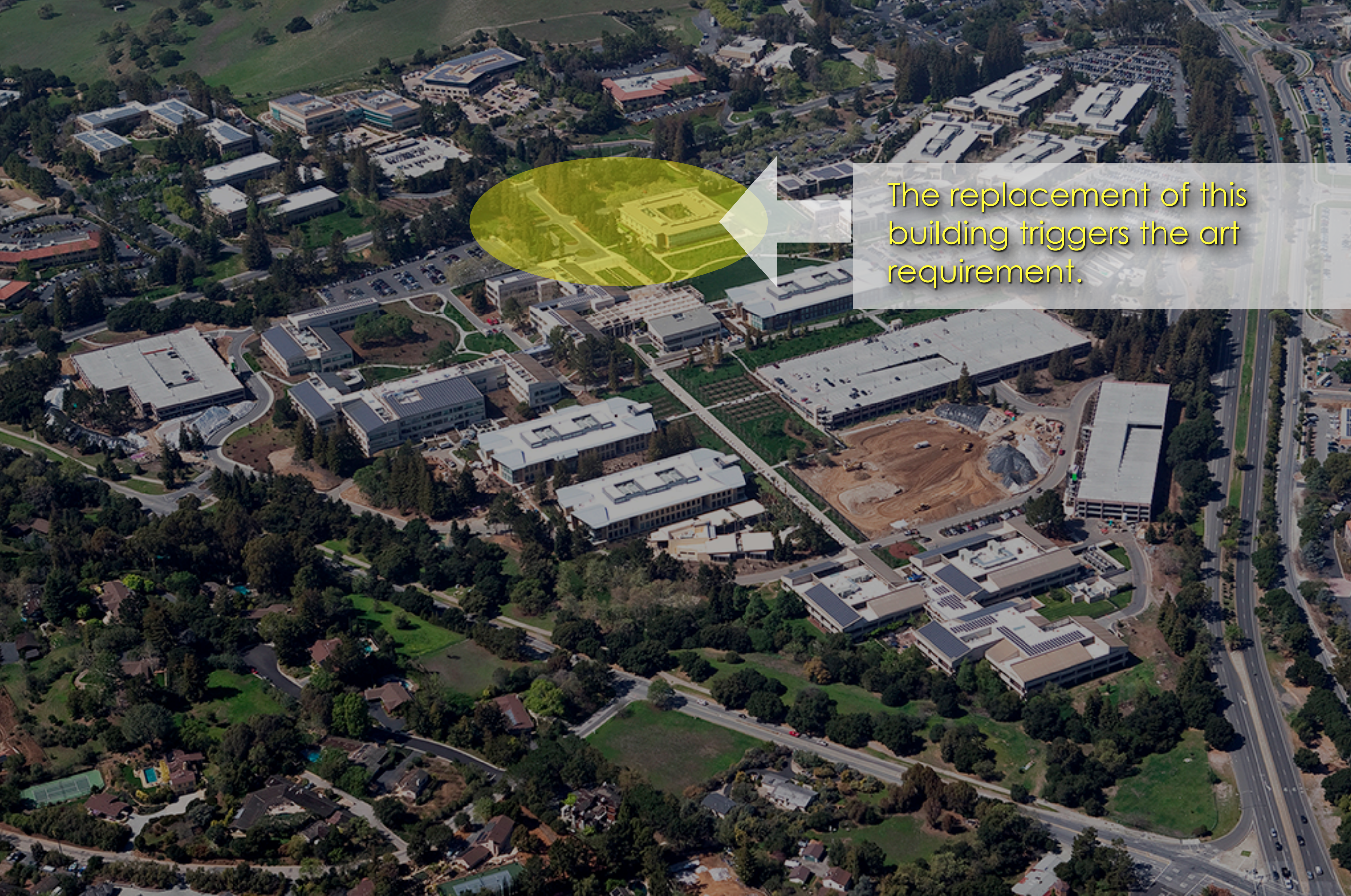

The replacement of this building triggers the art requirement.



HILLVIEW



Proposed location for art at the redesigned top of the Town Square monumental stairs at the main entrance to the campus.



HILLVIEW

# Proposed Art Location

Existing circle  
made smaller and  
moved back

Main Lobby

Town Square

Office

VBC on Ground Floor Front

CAROL A. DABB ART CONSULTANT • FORM4 ARCHITECTURE • STUDIO FIVE LANDSCAPE

VMWARE Phase 4  
Preliminary Art Presentation  
October 16, 2014

## HTG - MAIN ENTRY PRELIMINARY SITE PLAN





HILLVIEW

# Proposed Art Location

View to Hillview Ave.

View to new building

View to Main Lobby

Office

VBC on Ground Floor Front

Main Lobby

Town Square

CAROL A. DABB ART CONSULTANT • FORM4 ARCHITECTURE • STUDIO FIVE LANDSCAPE

VMWARE Phase 4  
Preliminary Art Presentation  
October 16, 2014

## HTG - MAIN ENTRY PRELIMINARY SITE PLAN







CAROL A. DABB ART CONSULTANT • FORM4 ARCHITECTURE • STUDIO FIVE LANDSCAPE

VMWARE Phase 4  
Preliminary Art Presentation  
October 16, 2014

HTG RENDERING  
VBC DROP OFF & ENTRY







# Town Square

*View looking up stairs from campus interior to proposed art installation (Hillview Avenue in the background)*

CAROL A. DABB ART CONSULTANT • FORM4 ARCHITECTURE • STUDIO FIVE LANDSCAPE

VMWARE Phase 4  
Preliminary Art Presentation  
October 16, 2014

SITE PHOTOS





# Town Square

*View standing at proposed art installation to interior of campus.*



CAROL A. DABB ART CONSULTANT • FORM4 ARCHITECTURE • STUDIO FIVE LANDSCAPE

VMWARE Phase 4  
Preliminary Art Presentation  
October 16, 2014

**SITE PHOTOS**







← New area for art behind top of stairs. →



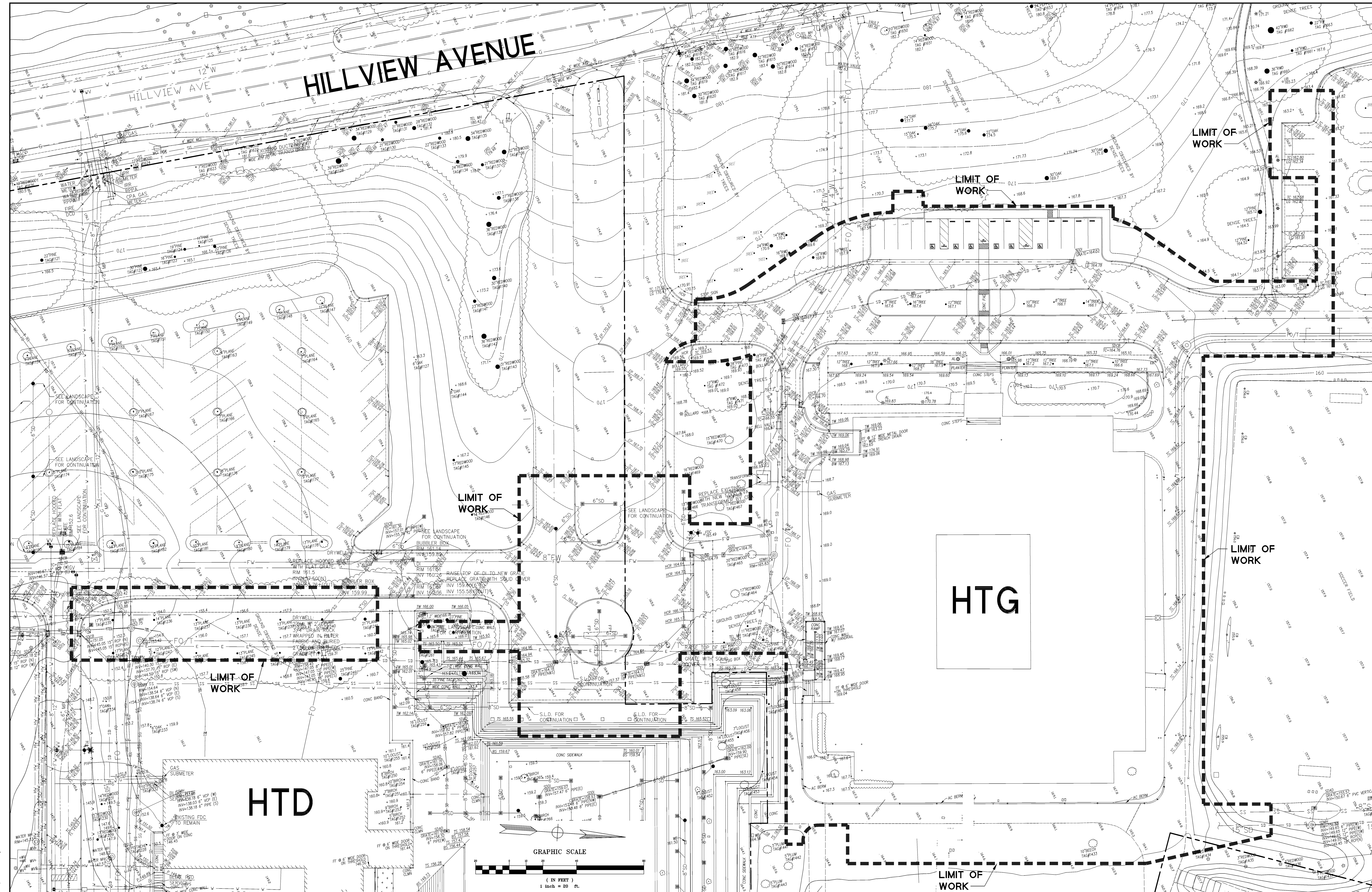

# VMware - Phase 4 Site Development

## PALO ALTO, CALIFORNIA

ARCHITECT:  
**FORM4 ARCHITECTURE, INC.**  
 126 POST STREET, 3RD FLOOR  
 SAN FRANCISCO, CA 94108  
 415.775.8748

**BKF**  
 ENGINEERS • SURVEYORS • PLANNERS  
 1650 TECHNOLOGY DRIVE,  
 SUITE 650  
 SAN JOSE, CA 95110  
 408/467-9100  
 408/467-9199 (FAX)

Form 4

Stamp:

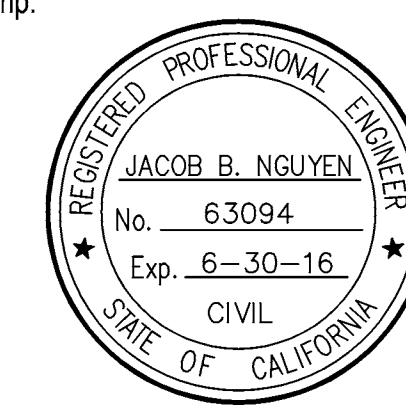

# Date Issue

# Date Issue

8-7-2014	Design Development
9-5-2014	100% Design Development

Sheet Title:  
**EXISTING SITE CONDITIONS**

Scale:





Sheet No:

**C1.0**

DRAWING NAME: VMware - Phase 4 Site Development  
 PROJECT FILE: VMware - Phase 4 Site Development  
 DATE: 9/15/14

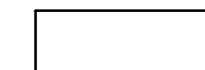
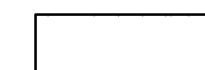
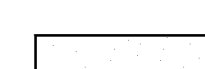

**LEGEND**

-  GRIND AND OVERLAY NEW AC OVER EXISTING, 2" THICK MINIMUM
-  ASPHALT CONCRETE PAVEMENT (3" AC/8"CL 2 AB, TI=5.5)
-  TEMPORARY ASPHALT CONCRETE PAVEMENT FOR CONFORM PURPOSES (3" AC/8"CL 2 AB, TI=5.5)
-  ADA ACCESSIBLE PATH OF TRAVEL
-  PROPOSED PAVEMENT MARKING WORDS PER CALTRANS STANDARD PLANS 2006, DETAILS A24D AND A24E.
-  PROPOSED PAVEMENT MARKING ARROWS PER CALTRANS STANDARD PLANS 2006, DETAILS A24A AND A24B.

**SITE KEY NOTES**

- ① CONCRETE VERTICAL CURB, SEE DETAIL 7/CD1.2
- ② CONCRETE CURB AND GUTTER, SEE DETAIL 8/CD1.1
- ③ CONCRETE CURB AND GUTTER WITH 12" MINIMUM OPENING, COBBLE SPILL PAD ON LANDSCAPE SIDE OF OPENING, SEE DETAIL 1/CD1.3
- ④ EXISTING CURB/GUTTER TO REMAIN
- ⑤ 4" WIDE WHITE PAVEMENT MARKING
- ⑥ WALKWAY (LANDSCAPE PLANS TO BE PROVIDED)
- ⑦ PLANTING AREA (LANDSCAPE PLANS TO BE PROVIDED)
- ⑧ EDGE OF PAVEMENT

**SITE NOTES**

1. CONTRACTOR SHALL PAINT "NO DUMPING/FLOWS TO BARRON CREEK" LOGO IN BLUE COLOR ON A WHITE BACKGROUND, ADJACENT TO ALL STORM DRAIN INLETS. STENCILS OF THE LOGO ARE AVAILABLE FROM THE PUBLIC WORKS ENVIRONMENTAL COMPLIANCE DIVISION, WHICH MAY BE CONTACTED AT (650) 329-2598.
2. ANY CONSTRUCTION WITHIN THE CITY RIGHT-OF-WAY MUST HAVE AN APPROVED PERMIT FOR CONSTRUCTION IN THE PUBLIC STREET PRIOR TO COMMENCEMENT OF THIS WORK. THE PERFORMANCE OF THIS WORK IS NOT AUTHORIZED BY THE BUILDING PERMIT ISSUANCE BUT SHOWN ON THE BUILDING PERMIT FOR INFORMATION ONLY.
3. CONTRACTOR SHALL SUBMIT A LOGISTICS PLAN TO THE PUBLIC WORKS DEPARTMENT PRIOR TO COMMENCING WORK THAT ADDRESSES ALL IMPACTS TO THE CITY'S RIGHT-OF-WAY.
4. TREES CAN NOT BE PLANTED WITHIN 10 FEET OF EXISTING WATER, GAS OR SEWER LINES OR METERS.
5. ALL EXISTING PAVEMENT MARKINGS IN CONFLICT OF THESE PLANS TO BE REMOVED BY CONTRACTOR.
6. WALKWAYS ALONG ADA ACCESSIBLE PATHS OF TRAVEL:
  - CONTINUOUSLY ACCESSIBLE
  - MAXIMUM 1/2" CHANGES IN ELEVATION, OR PROVIDE CURB RAMPS COMPLYING WITH CBC 1127B.5
  - MINIMUM 48" IN WIDTH
  - WHERE SLOPE EXCEEDING 5% SHALL HAVE PEDESTRIAN RAMPS COMPLYING WITH CBC 1133B.5 AND 1133B.7

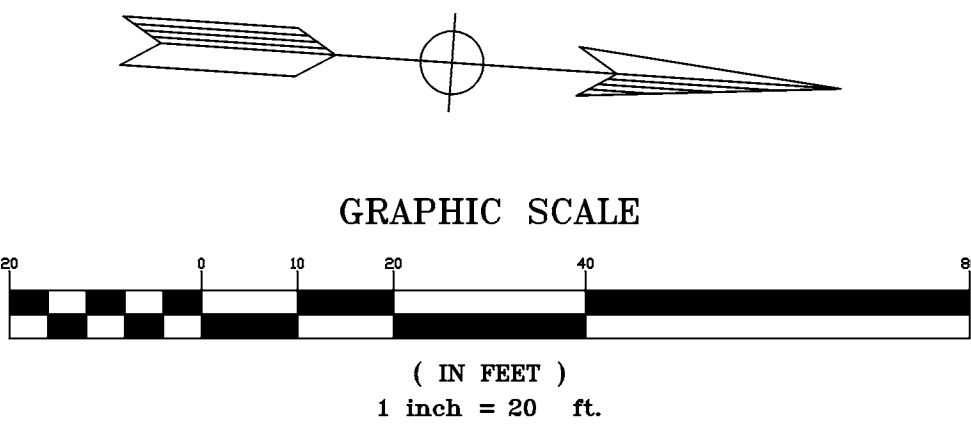
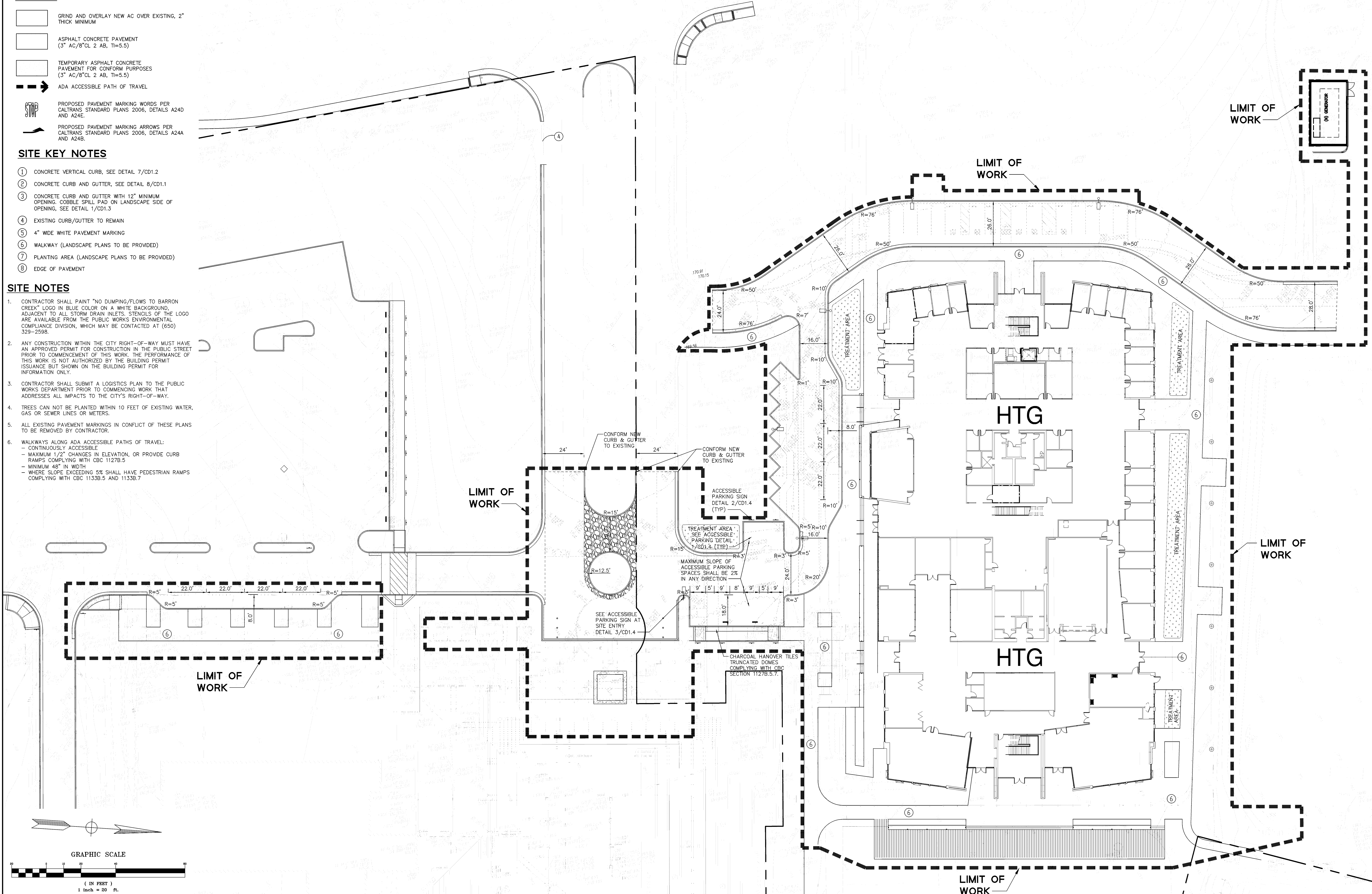

**VMware - Phase 4 Site Development**  
PALO ALTO, CALIFORNIA

ARCHITECT:  
FORM4 ARCHITECTURE, INC.  
126 POST STREET, 3RD FLOOR  
SAN FRANCISCO, CA 94108  
415.775.8748

**Bkf**  
ENGINEERS • SURVEYORS • PLANNERS  
1650 TECHNOLOGY DRIVE,  
SUITE 650  
SAN JOSE, CA 95110  
408/467-9100  
408/467-9199 (FAX)

**Form 4**

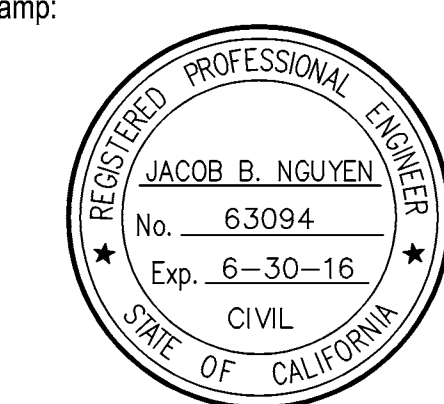
Stamp:  

#	Date	Issue

#	Date	Issue
	8-7-2014	Design Development
	9-5-2014	100% Design Development

Sheet Title:  
**SITE PLAN**  
Scale:  
Sheet No:  
**C3.1**

DRAWING NAME: VMware - Phase 4 Site Development  
 PROJECT NAME: VMware - Phase 4 Site Development  
 DATE: 8/7/2014  
 DRAWN BY: J. NGUYEN  
 CHECKED BY: J. NGUYEN